

Drawers & Runners

Tekform Slimline Drawer

Product Guide

Tekform Slimline Drawer

Page

Tekform Slimline Drawer SDW70

1.12

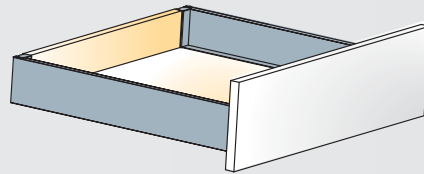

Tekform Slimline Drawer SDW100

1.14

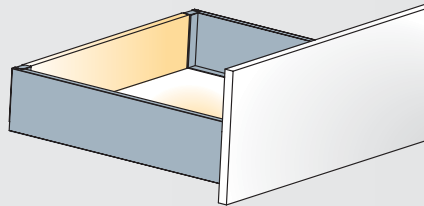

Tekform Slimline Drawer SDW145

1.16

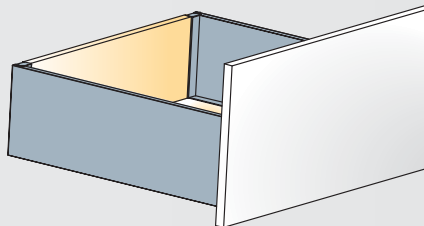

Tekform Slimline Drawer SDW182

1.18

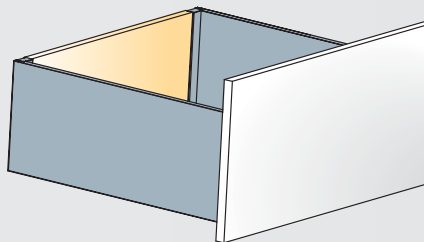

Inner Slimline Drawer Fronts

Inner Drawer Front for
Tekform Slimline Drawer
SDW70

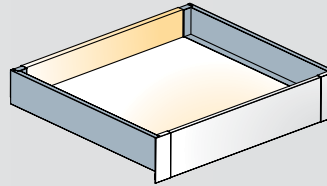

1.20

Inner Drawer Front for
Tekform Slimline Drawer
SDW70 with Glass

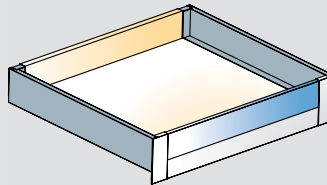

1.22

Inner Drawer Front for
Tekform Slimline Drawer
SDW145 with Bar

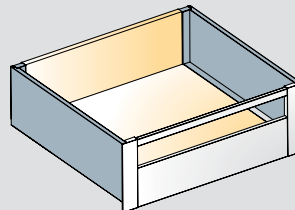

1.24

Inner Drawer Front for
Tekform Slimline Drawer
SDW145 with Glass

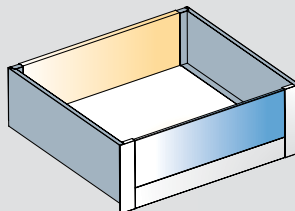

1.26

Inner Drawer Front for
Tekform Slimline Drawer
SDW182 with Bar

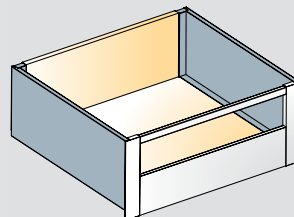

1.28

Inner Drawer Front for
Tekform Slimline Drawer
SDW182 with Glass

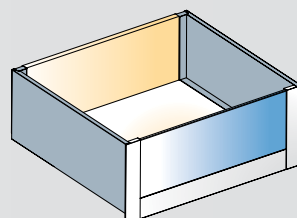

1.30

Tekform Slimline Drawer



Narrow sides

- Sleek look with 14mm thickness
- Efficient utilisation of drawer space

'EasyFix' front panel connector

- Hand insertion
- Quarter turn lock
- Repeatable assembly and disassembly possible

Flexibility of runner system

- Same drilling specification as Tekform Double Wall Drawer
- Same machinery settings as Tekform Double Wall Drawer

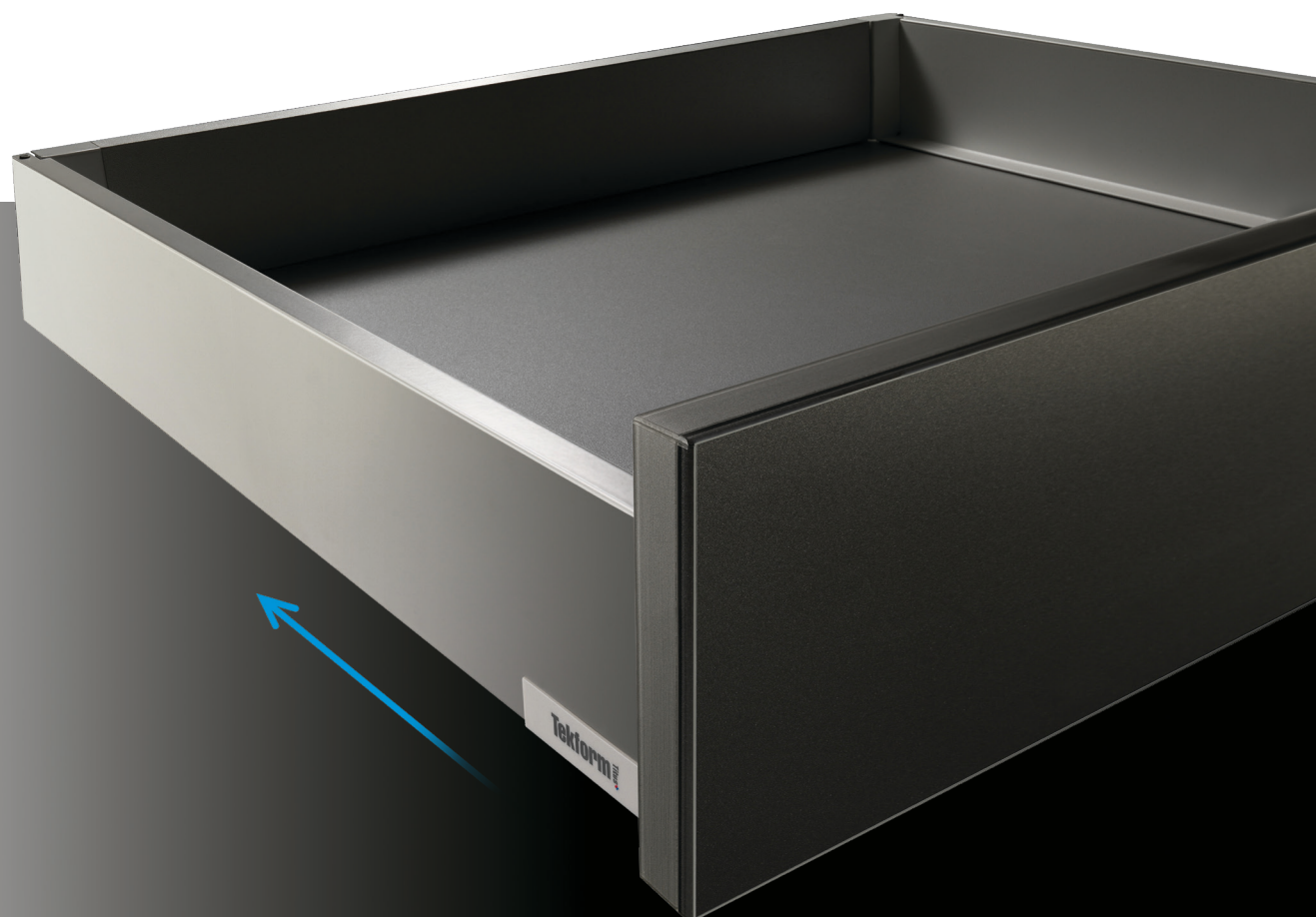

Expanded tolerances

- Precise drawer alignment
- Smooth and silent operation
- Improved drawer stability in open position
- +/- 1mm tolerance on bottom panel width size

Integrated Titus damper

- Life-long consistent soft closing performance at various closing speeds
- 'ConfidentClose' - fast closing, late start deceleration action, quiet landing
- Low pull-out force

Quality certified

- By European specialised institutions

Tekform Slimline Drawer Information

Technical Guide

How to choose the appropriate drawer dimension?

Select the drawer size based on available cabinet space. Please refer to the below chart with indicated minimum space

required in cabinet to assist in choosing the appropriate drawer system.

Tekform Drawer nominal length (NL) in mm

NL	270	300	350	400	450	500	550
	Tekform Drawer			Tekform Drawer with Inner Front			
	Min. height (H) required	Cabinet depth (D)	Min. height (H) required	Cabinet depth (D)			
Tekform Slimline Drawer SDW70	115mm	NL+min 3mm	115mm	NL+min 12mm			
Tekform Slimline Drawer SDW100	147mm	NL+min 3mm	NA	NA			
Tekform Slimline Drawer SDW145	198mm	NL+min 3mm	198mm	NL+min 12mm			
Tekform Slimline Drawer SDW182	230mm	NL+min 3mm	230mm	NL+min 12mm			

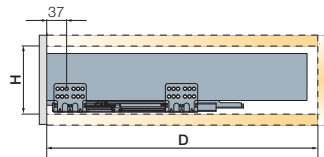

How to fix drawer sides to the front panel?

The Tekform Drawer is available with 'EasyFix' or screw-in front connectors.



'EasyFix' front connector

- Hand insertion
- Quarter turn locking system
- Expandable plastic dowel
- Easy assembly and disassembly of front panel

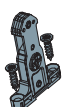
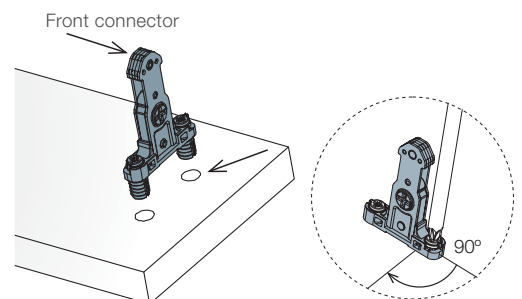

Screw-in front connector

- Reliable connection
- Fixing with Ø3.5x15mm screw (screws are not included)

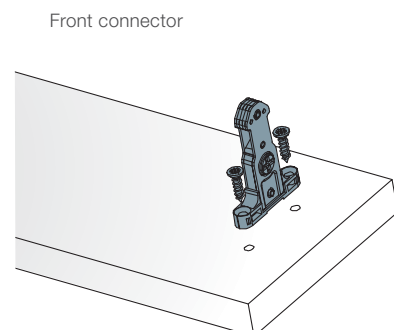

Bottom panel and back panel cutting dimensions

Dimensions of bottom and back panel depend on:

- Cabinet width
- Nominal drawer length
- Drawer height

Tekform Drawer nominal length (NL) in mm

NL	270	300	350	400	450	500	550
----	-----	-----	-----	-----	-----	-----	-----

Cabinet width

ECW: External cabinet width
ICW: Internal cabinet width
NL: Nominal length of drawer

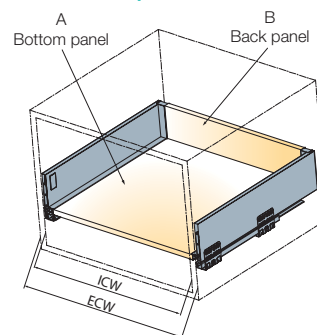

Back panel cutting dimensions

Back panel height depends on the selected drawer height.

	H back panel
SDW70	68
SDW100	100
SDW145	151
SDW182	183

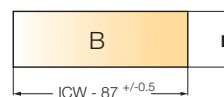

Bottom panel cutting dimensions

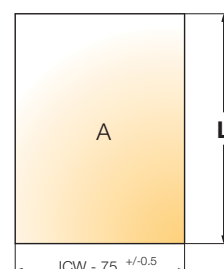

NL	270	300	350	400	450	500	550
L	260	290	340	390	440	490	540

NL= Tekform Drawer nominal length (in mm)

Tekform Slimline Drawer Information

Technical Guide

How to choose the appropriate drawer runner fixing positions?

Drawer fixing positions depend on the chosen drawer front type.

Tekform Slimline Drawer with standard front

When a standard drawer front is applied, use the third hole on the drawer runner for fixing.

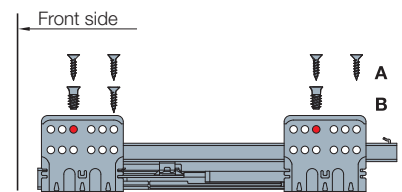

Tekform Slimline Drawer with inner front

When an inner drawer front is applied, use the second hole on the drawer runner for fixing.

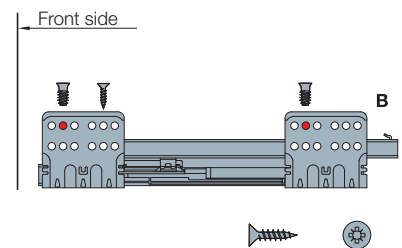

Load capacity

Drawer load capacity is 40kg.

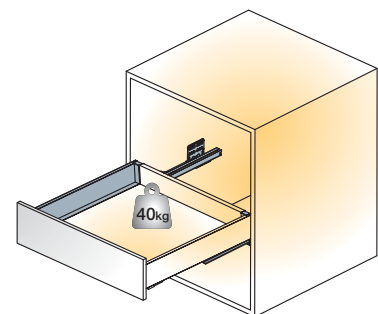

Expanded tolerances

Tekform drawers provide expanded tolerances in cabinet construction and assure:

- Precise drawer alignment
- Smooth and silent operation
- Improved drawer stability in open position
- The Tekform Drawer provides tolerance of +/-1mm on bottom panel width size

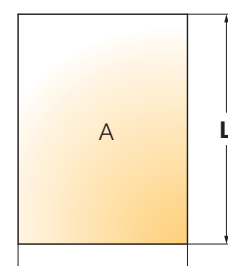

bottom panel width tolerance +/- 1mm



Adjustment needs to be done on both sides of the drawer

Adjustments

Side adjustment

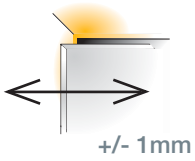

Side adjustment is done via the adjustment screw on the drawer side. Tighten the screw to adjust.

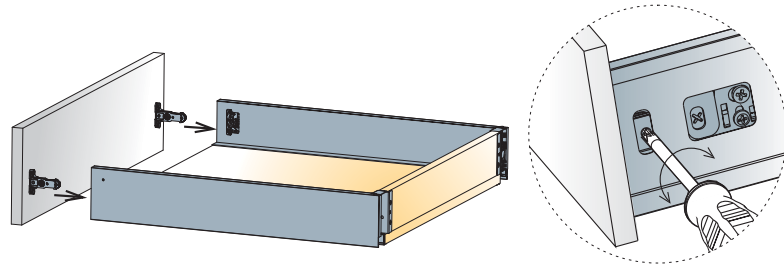

Height adjustment

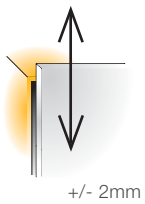

Height adjustment is done via the cam. First, release the locking screw and tighten it back after the front is adjusted.

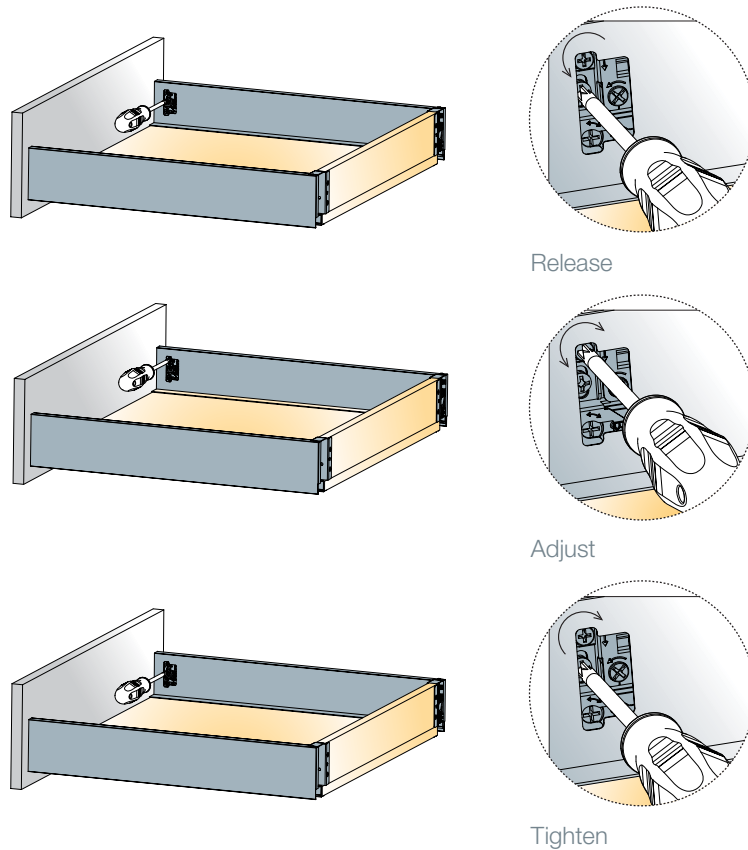

Key Design Choices

'ConfidentClose'

Fast closing

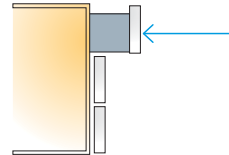

Late start of deceleration action

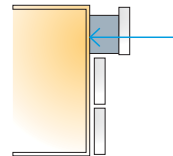

Quiet landing

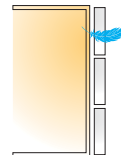

CAF Consumer Assembly Friendliness

'EasyFix' front panel connector with expandable plastic dowel provides:

- Quick, tool-free insertion
- Quarter turn lock
- Repeatable assembly and disassembly

Front connector

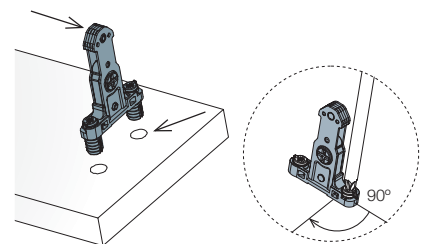

Titus hydraulic damper

Designed and produced in-house.

- Reliable and consistent life-long damping
- Smooth closing
- Dampers' consistency over high volume production runs assured
- 100% automated quality check



Damping action

Even and smooth soft closing action.

- Soft and reliable closing



Flat damping curve shows the uniform action produced during damper closing at a defined speed.

Tekform Slimline Drawer SDW70

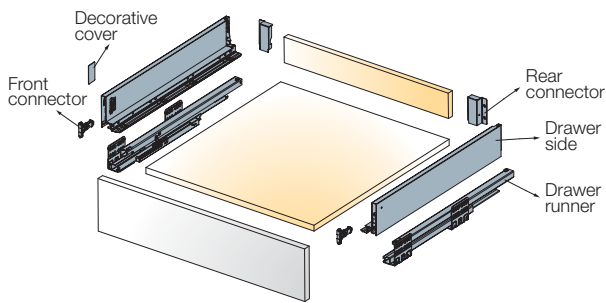
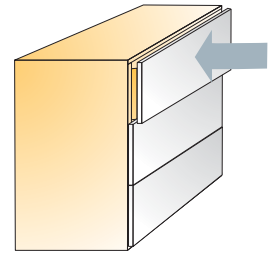

Cutting dimensions details

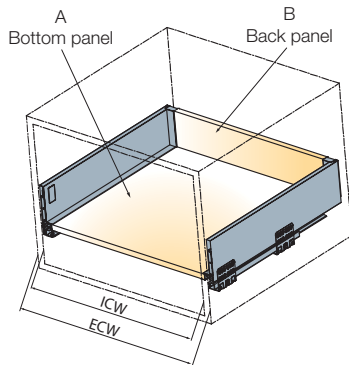

ECW: External cabinet width
 ICW: Internal cabinet width
 NL: Nominal length of drawer

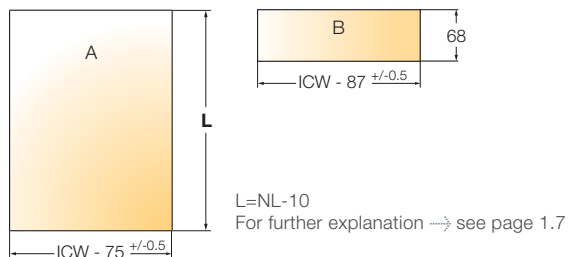

Nominal length (mm)	with EasyFix front connector	with Screw-in front connector	Color	
	Item number for a set	Item number for a set	White	Anthracite grey
270	655.8T27 →	655.8E27 →	150.00	185.00
300*	655.8T30 →	655.8E30 →	150.00	185.00
350	655.8T35 →	655.8E35 →	150.00	185.00
400	655.8T40 →	655.8E40 →	150.00	185.00
450	655.8T45 →	655.8E45 →	150.00	185.00
500	655.8T50 →	655.8E50 →	150.00	185.00
550	655.8T55 →	655.8E55 →	150.00	185.00
One set consists of				
	Drawer sides		2 pcs	
	Drawer runners		2 pcs	
	^Front connectors		2 pcs	
	Rear connectors		2 pcs	
	Covers		2 pcs	
	Mounting instructions		1 pce	

Screws not included. ^Front connectors determined by order code.



- Drawer runner type
- Load capacity
- Minimum height space required
- Wooden back panel thickness
- Wooden bottom panel thickness

Full extension
40kg
115mm
16mm
16mm

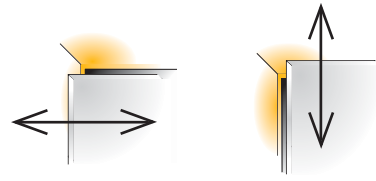

Side adjustment
+1/-1mm

Height adjustment
+2/-2mm

For further explanation → see page 1.9

Installation dimensions

Minimum space required for the cabinet

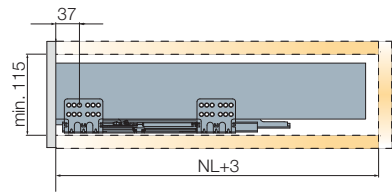

Drilling dimensions for the front panel

EasyFix attachment

Screw-in attachment

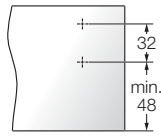
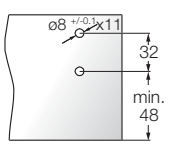

Mounting dimensions for the back panel

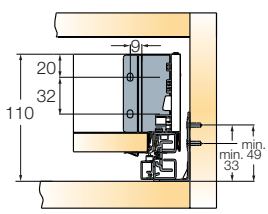

Installation dimensions for the front panel

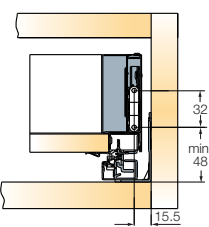

Drawer runner fixing positions

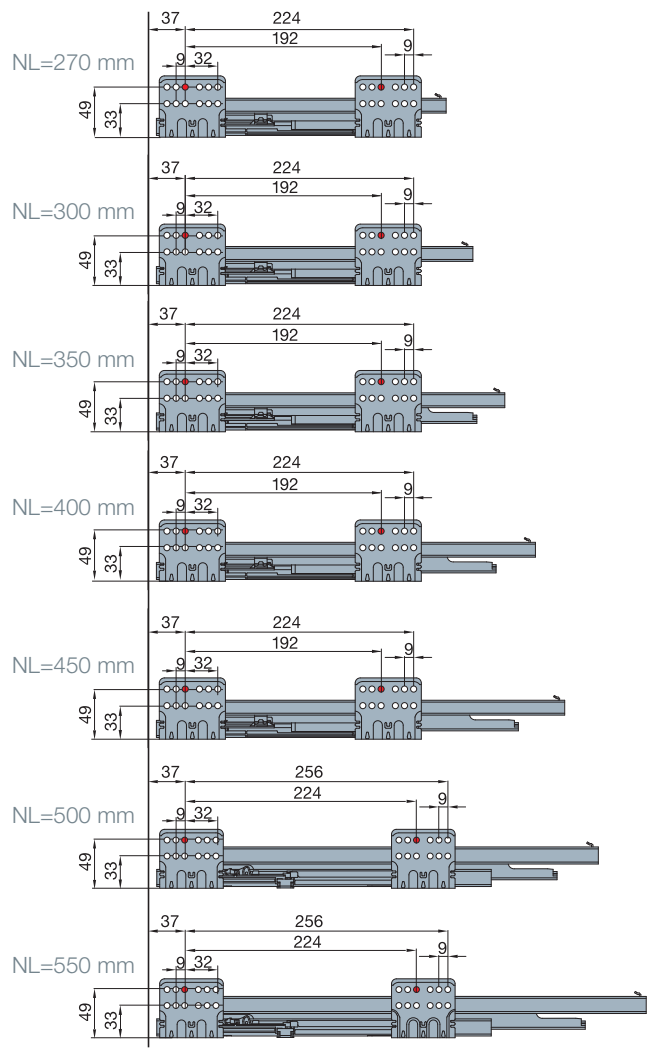
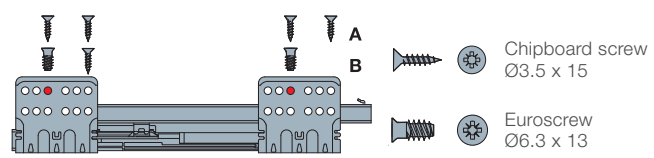

A trial mounting is always recommended. For further information please contact Titus Tekform.

Tekform Slimline Drawer SDW100

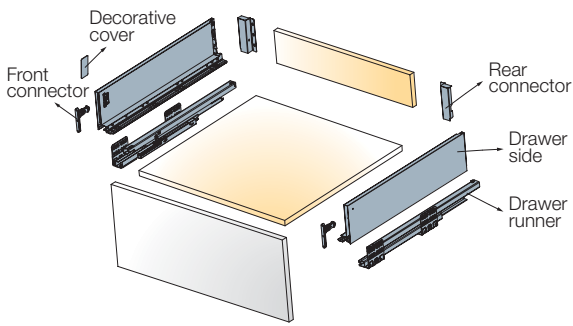
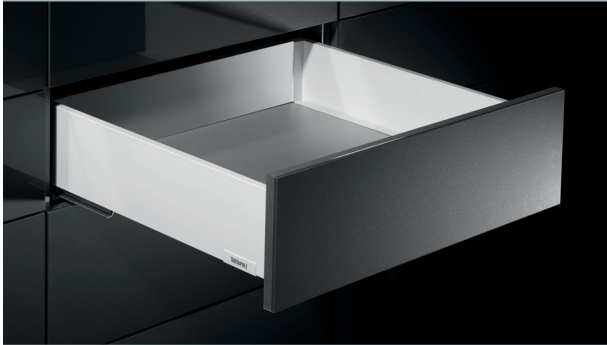
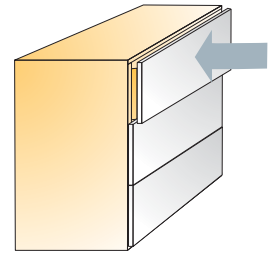

Cutting dimensions details

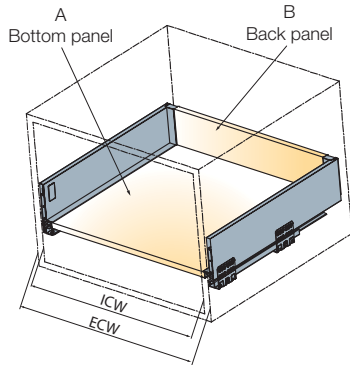

ECW: External cabinet width
 ICW: Internal cabinet width
 NL: Nominal length of drawer

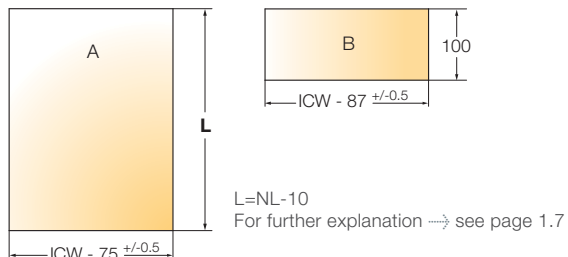

Nominal length (mm)	with EasyFix front connector	with Screw-in front connector	Color	
	Item number for a set	Item number for a set	White	Anthracite grey
270	655.8U27 →	655.8F27 →	150.00	185.00
300*	655.8U30 →	655.8F30 →	150.00	185.00
350	655.8U35 →	655.8F35 →	150.00	185.00
400	655.8U40 →	655.8F40 →	150.00	185.00
450	655.8U45 →	655.8F45 →	150.00	185.00
500	655.8U50 →	655.8F50 →	150.00	185.00
550	655.8U55 →	655.8F55 →	150.00	185.00
One set consists of				
	Drawer sides		2 pcs	
	Drawer runners		2 pcs	
	^Front connectors		2 pcs	
	Rear connectors		2 pcs	
	Covers		2 pcs	
	Mounting instructions		1 pce	

Screws not included. ^Front connectors determined by order code.

- Drawer runner type
- Load capacity
- Minimum height space required
- Wooden back panel thickness
- Wooden bottom panel thickness

Full extension
40kg
147mm
16mm
16mm

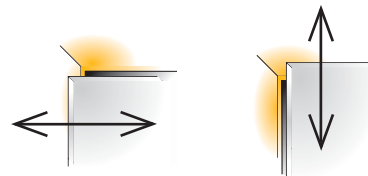

Side adjustment
+1/-1mm

Height adjustment
+2/-2mm

For further explanation → see page 1.9

Installation dimensions

Minimum space required for the cabinet

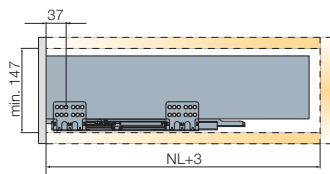

Drilling dimensions for the front panel

EasyFix attachment

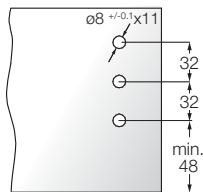

Screw-in attachment

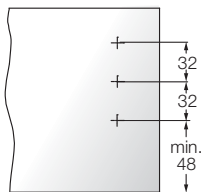

Mounting dimensions for the back panel

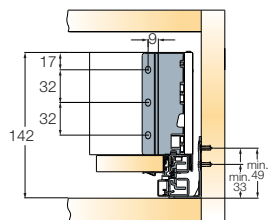

Installation dimensions for the front panel

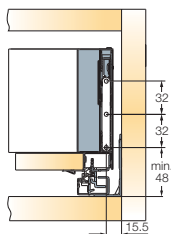

Drawer runner fixing positions

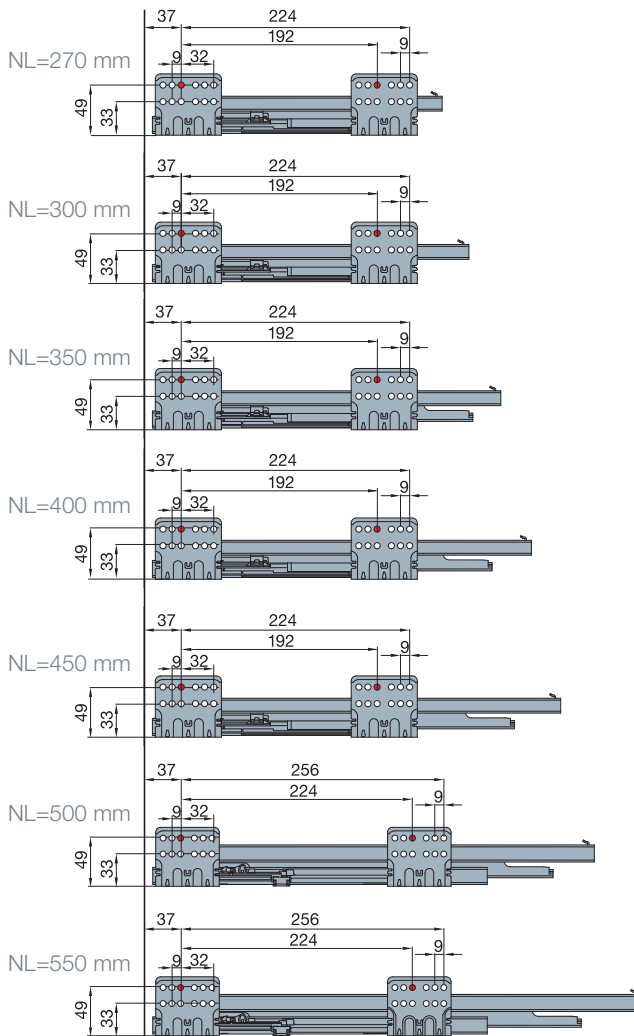
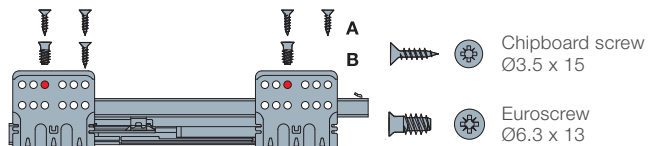

A trial mounting is always recommended. For further information please contact Titus Tekform.

Tekform Slimline Drawer SDW145

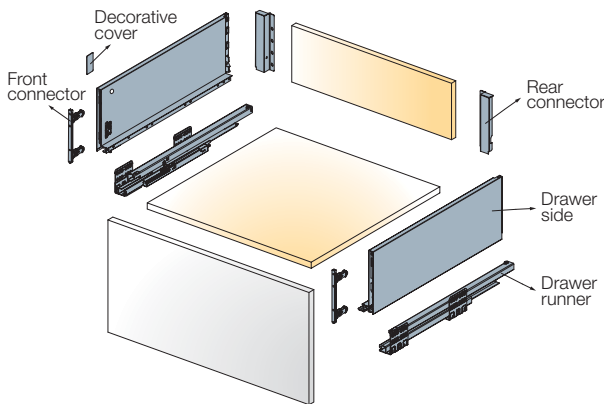
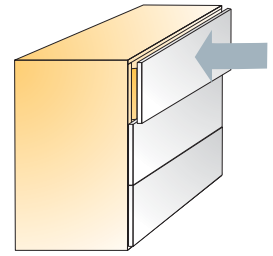

Cutting dimensions details

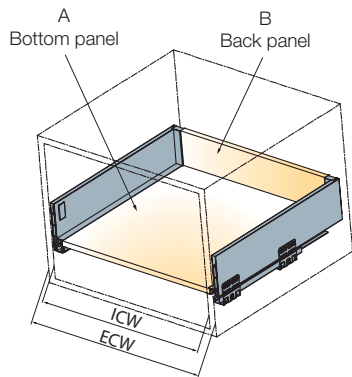

ECW: External cabinet width
 ICW: Internal cabinet width
 NL: Nominal length of drawer

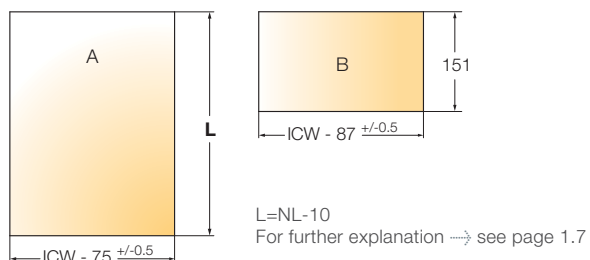

Nominal length (mm)	with EasyFix front connector	with Screw-in front connector	Color	
	Item number for a set	Item number for a set	White	Anthracite grey
270	655.8V27 →	655.8G27 →	150.00	185.00
300*	655.8V30 →	655.8G30 →	150.00	185.00
350	655.8V35 →	655.8G35 →	150.00	185.00
400	655.8V40 →	655.8G40 →	150.00	185.00
450	655.8V45 →	655.8G45 →	150.00	185.00
500	655.8V50 →	655.8G50 →	150.00	185.00
550	655.8V55 →	655.8G55 →	150.00	185.00
One set consists of				
	Drawer sides		2 pcs	
	Drawer runners		2 pcs	
	^Front connectors		2 pcs	
	Rear connectors		2 pcs	
	Covers		2 pcs	
	Mounting instructions		1 pce	

Screws not included. ^Front connectors determined by order code.



- Drawer runner type
- Load capacity
- Minimum height space required
- Wooden back panel thickness
- Wooden bottom panel thickness

Full extension
40kg
198mm
16mm
16mm

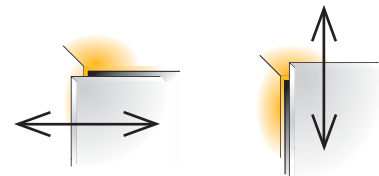

Side adjustment
+1/-1mm

Height adjustment
+2/-2mm

For further explanation → see page 1.9

Installation dimensions

Minimum space required for the cabinet

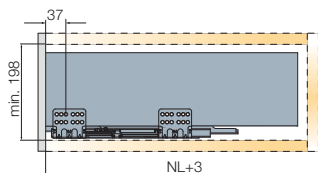

Drilling dimensions for the front panel

EasyFix attachment

Screw-in attachment

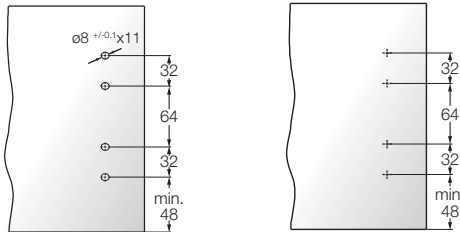

Mounting dimensions for the back panel

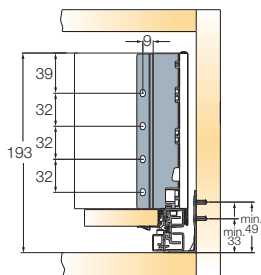

Installation dimensions for the front panel

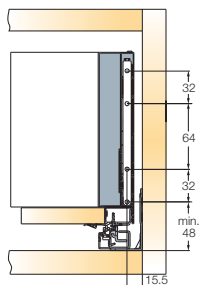

Drawer runner fixing positions

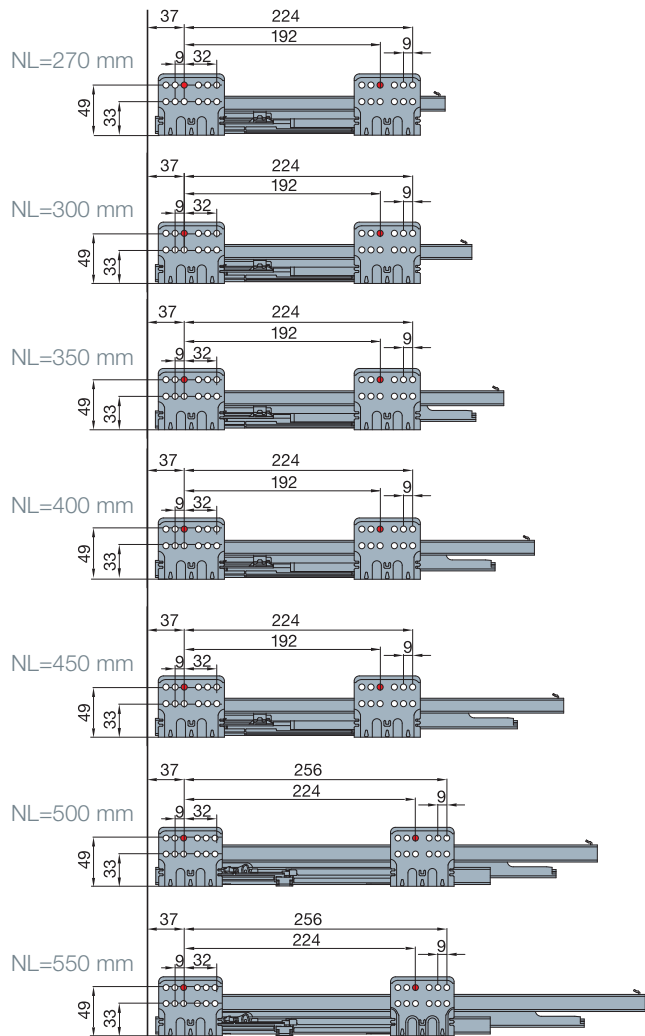
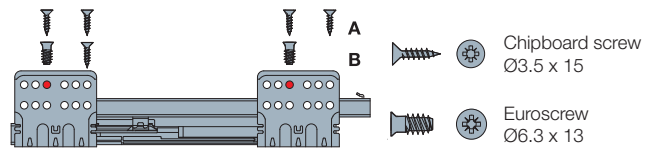

A trial mounting is always recommended. For further information please contact Titus Tekform.

Tekform Slimline Drawer SDW182

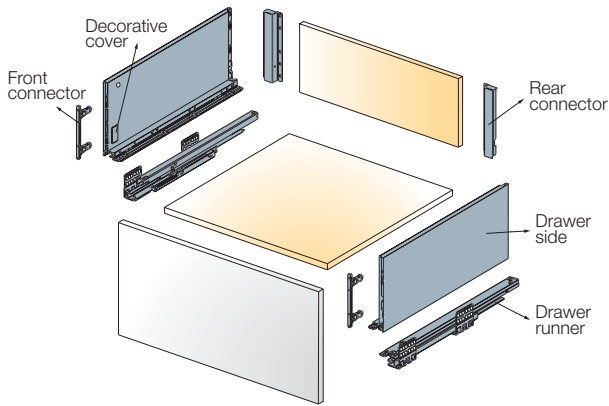
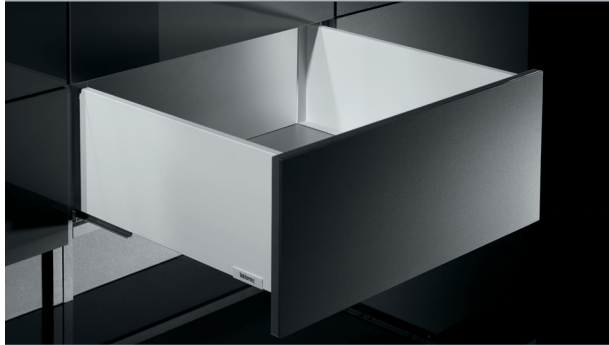
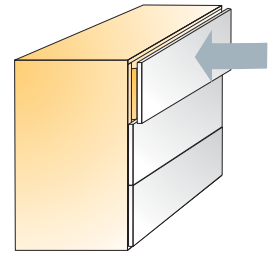

Cutting dimensions details

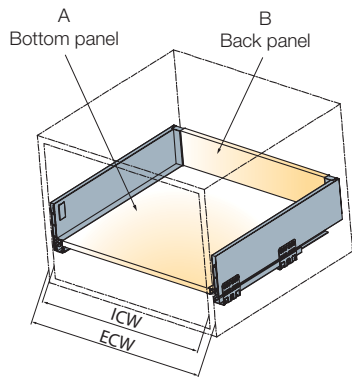

ECW: External cabinet width
 ICW: Internal cabinet width
 NL: Nominal length of drawer

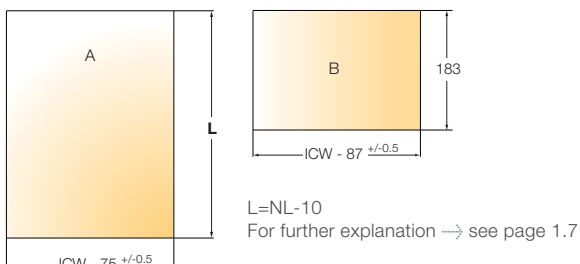

Nominal length (mm)	with EasyFix front connector	with Screw-in front connector	Color	
	Item number for a set	Item number for a set	White	Anthracite grey
270	655.8Z27 →	655.8H27 →	150.00	185.00
300*	655.8Z30 →	655.8H30 →	150.00	185.00
350	655.8Z35 →	655.8H35 →	150.00	185.00
400	655.8Z40 →	655.8H40 →	150.00	185.00
450	655.8Z45 →	655.8H45 →	150.00	185.00
500	655.8Z50 →	655.8H50 →	150.00	185.00
550	655.8Z55 →	655.8H55 →	150.00	185.00
One set consists of				
	Drawer sides		2 pcs	
	Drawer runners		2 pcs	
	^Front connectors		2 pcs	
	Rear connectors		2 pcs	
	Covers		2 pcs	
	Mounting instructions		1 pce	

Screws not included. ^Front connectors determined by order code.



Drawer Front Marking Jig for
 Tekform Slimline SDW182
 655.8018

- Drawer runner type
- Load capacity
- Minimum height space required
- Wooden back panel thickness
- Wooden bottom panel thickness

Full extension
40kg
230mm
16mm
16mm

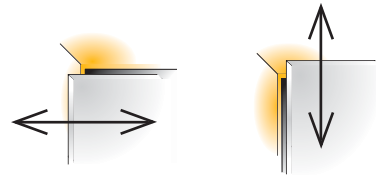

Side adjustment
+1/-1mm

Height adjustment
+2/-2mm

For further explanation → see page 1.9

Installation dimensions

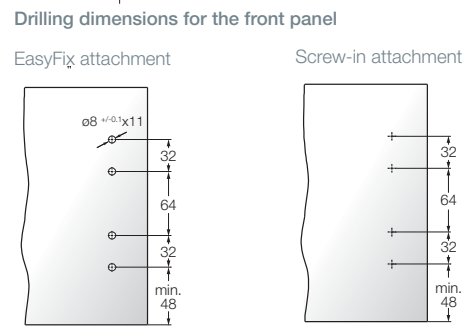
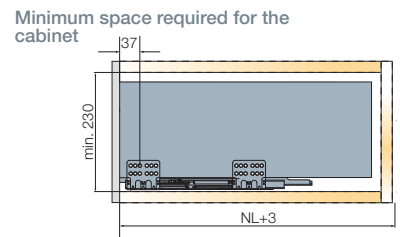

Mounting dimensions for the back panel

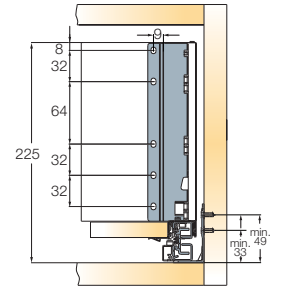

Installation dimensions for the front panel

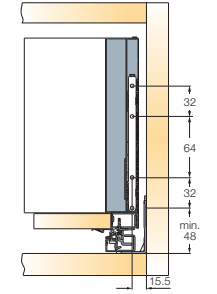

Drawer runner fixing positions

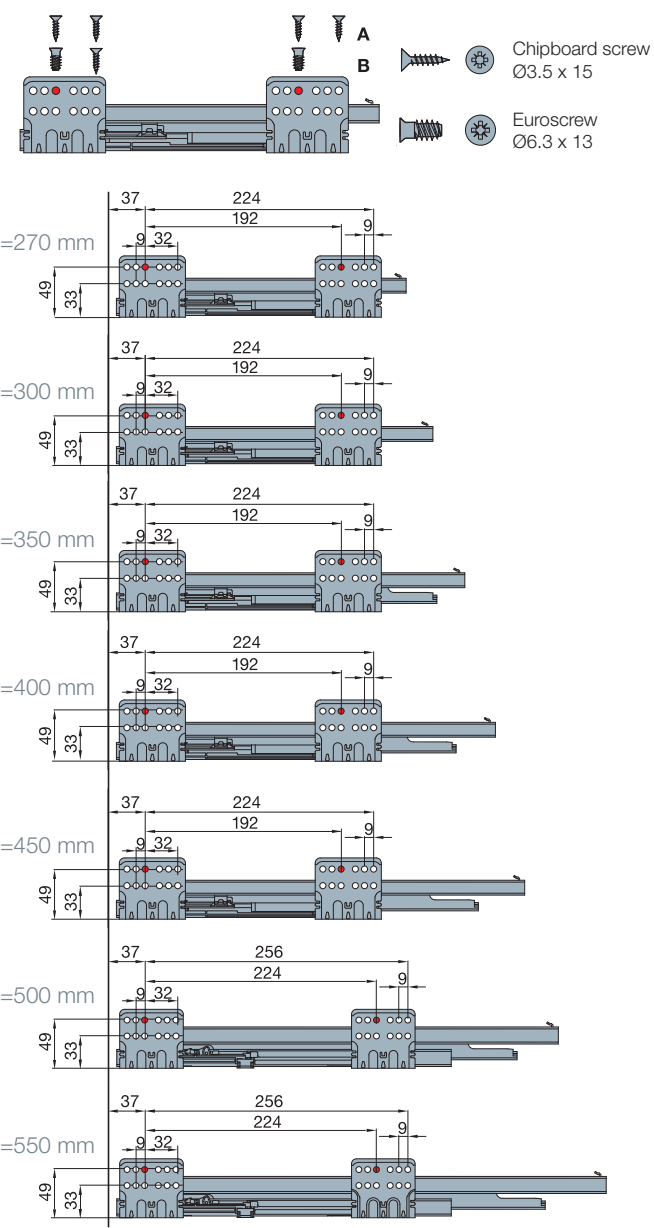

A trial mounting is always recommended. For further information please contact Titus Tekform.

Inner Drawer Front for Tekform Slimline Drawer SDW70

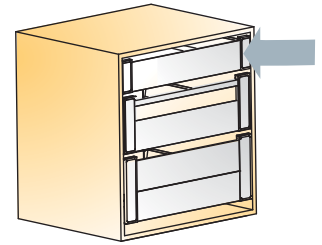

Front Panel

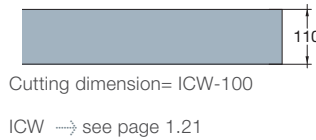
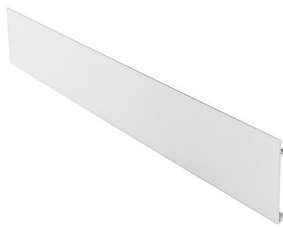

Made of aluminium

Front Bracket Set



Made of aluminium and plastic

External cabinet width (mm)	Cabinet side thickness=16mm		Color	
	Item number		White	Anthracite grey
600	655.8185 →		511.00	515.00
1200	655.8189 →		511.00	515.00
	655.8065 →		150.00	185.00



Front panel support clip
002110.885.300 white

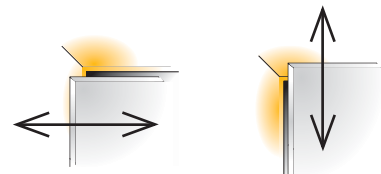
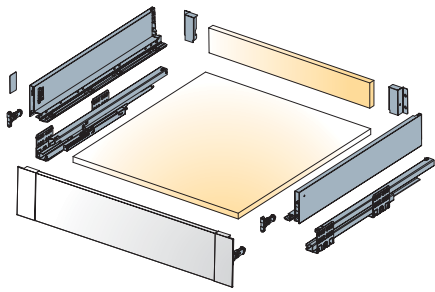

Side adjustment
+1/-1mm

Height adjustment
+2/-2mm

For further explanation → see page 1.9-1.10

Installation dimensions

Minimum space required for the cabinet

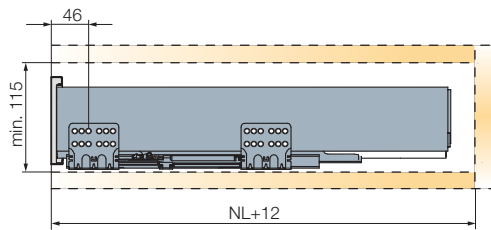

Cutting dimensions details

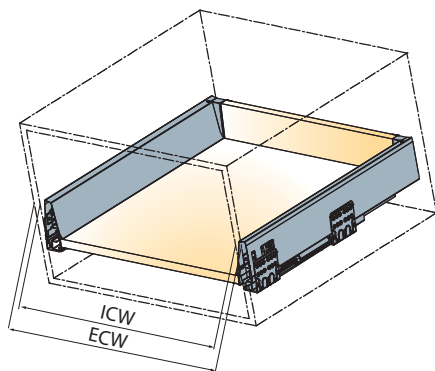

ECW: External cabinet width
ICW: Internal cabinet width
NL: Nominal length of drawer

Drawer runner fixing positions

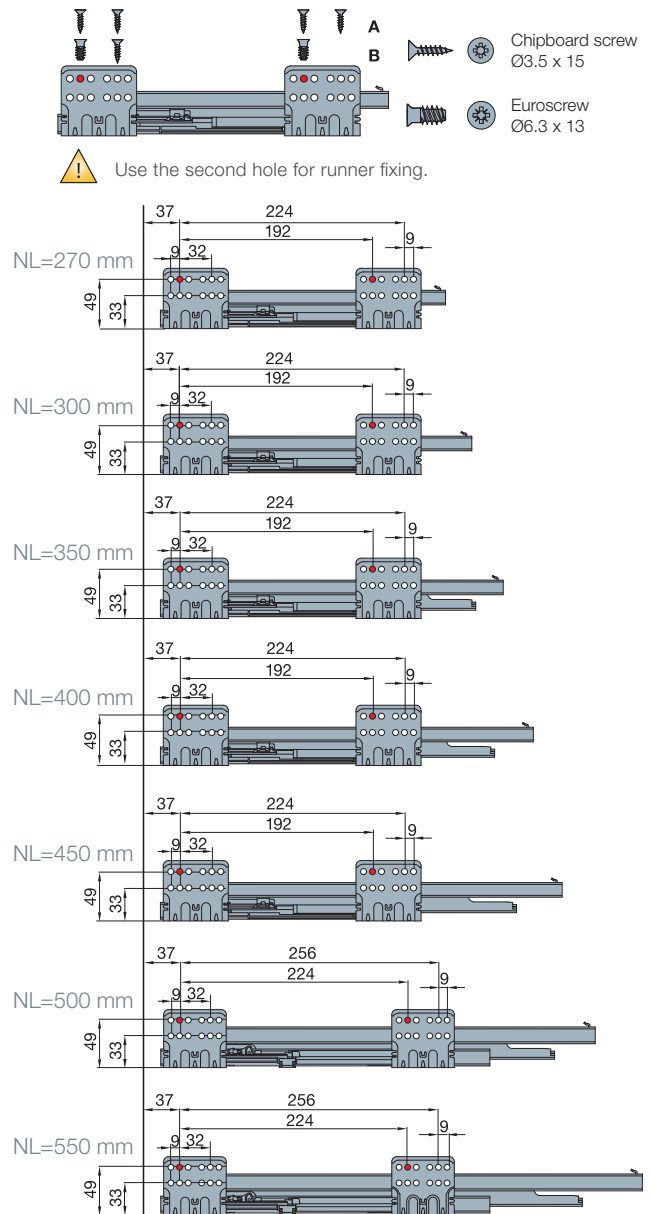

Inner Drawer Front for Tekform Slimline Drawer SDW70 with Glass

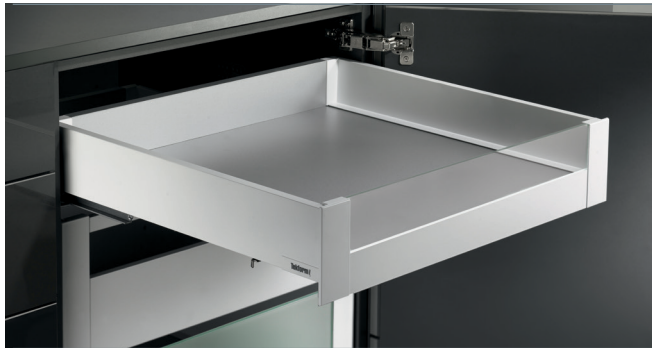
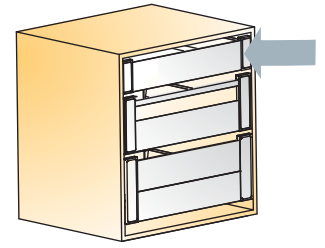

Inner Drawer Front, Assembly Set

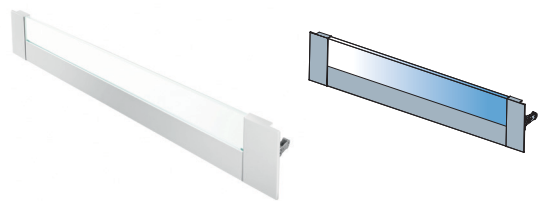

Made of aluminium and glass

Front Panel

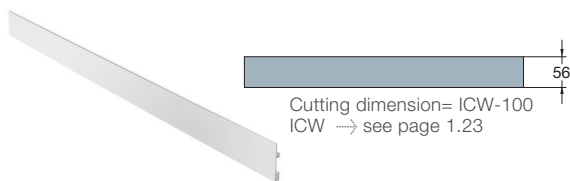

Made of aluminium

Low Glass

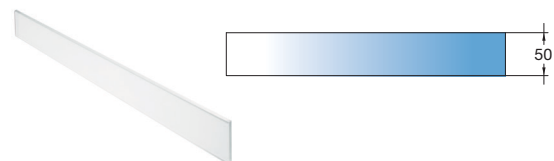

Made of glass

Front Bracket Set



Made of aluminium and plastic

External cabinet width (mm)	Cabinet side thickness=16mm	Material/Color Options			
		White	Anthracite grey	Frosted glass	Transparent glass
600	655.8285 →	511.00	515.00		
1200	655.8209 →	511.00	515.00		
600	655.8295 →			391.00*	392.00
1200	655.8299 →			391.00*	392.00
	655.8305 →	150.00	185.00		



Front panel support clip
002110.885.300 white

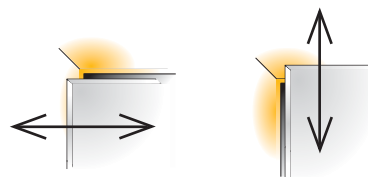
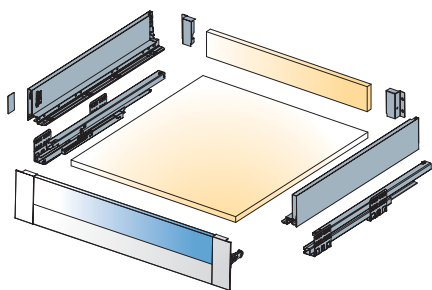

Side adjustment
+1/-1mm

Height adjustment
+2/-2mm

For further explanation → see page 1.9-1.10

Installation dimensions

Minimum space required for the cabinet

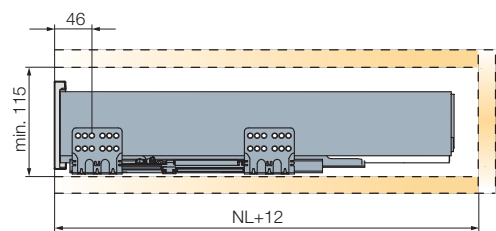

Cutting dimensions details

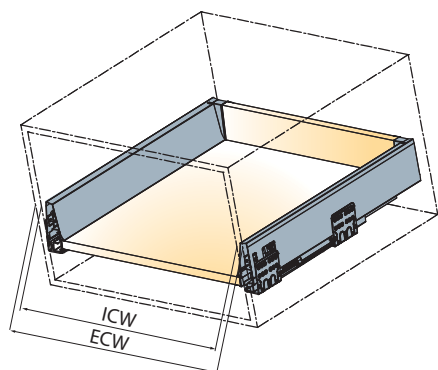

ECW: External cabinet width
ICW: Internal cabinet width
NL: Nominal length of drawer

Drawer runner fixing positions

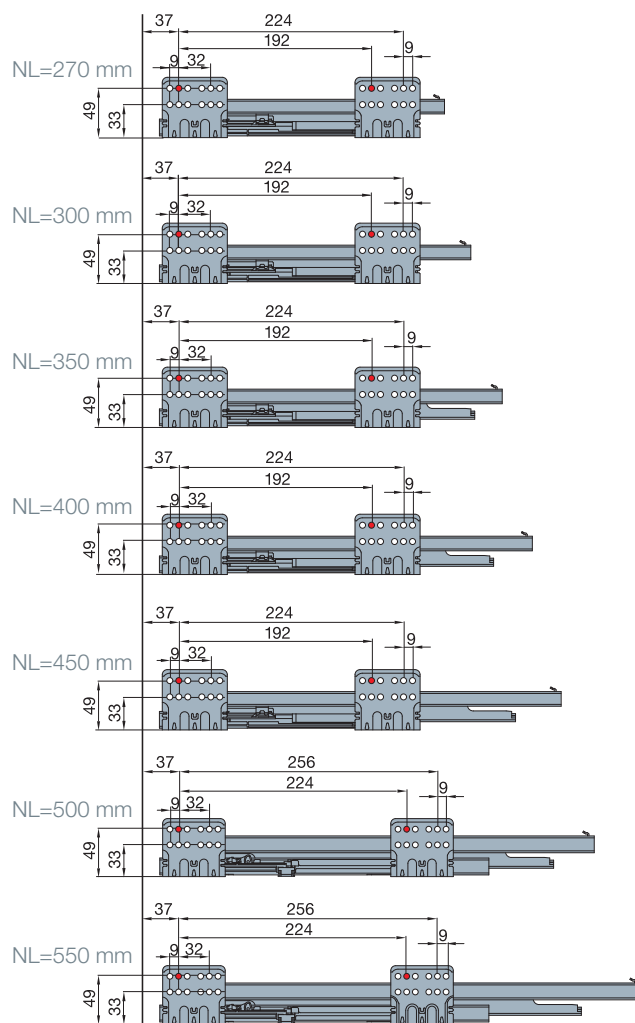
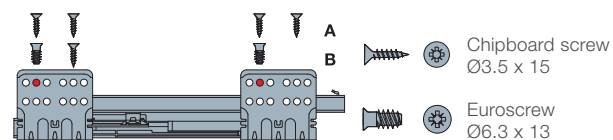

Inner Drawer Front for Tekform Slimline Drawer SDW145 with Bar

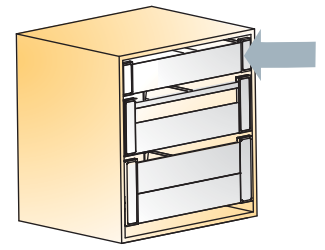

Inner Drawer Front, Assembly Set

External cabinet width (mm)	Cabinet side thickness=16mm		Color	
	Item number		White	Anthracite grey
600	655.8190 →		511.00	515.00
1200	655.8194 →		511.00	515.00



Made of aluminium and plastic

Front Bar



Made of aluminium

600	655.8210 →		511.00	515.00
1200	655.8214 →		511.00	515.00

Front Panel



Made of aluminium

600	655.8185 →		511.00	515.00
1200	655.8189 →		511.00	515.00

Front Bracket Set



Made of aluminium and plastic

	655.8101 →		350.00	385.00
--	------------	--	--------	--------



Front panel support clip
002110.885.300 white

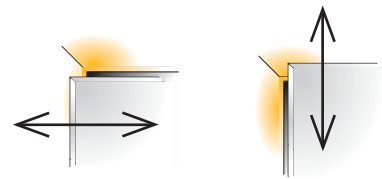
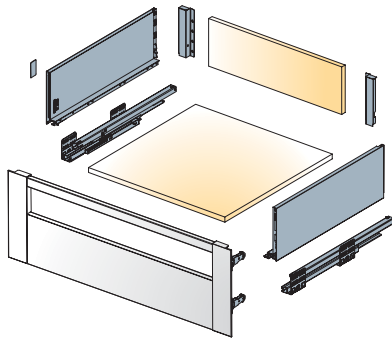

Side adjustment
+1/-1mm

Height adjustment
+2/-2mm

For further explanation → see page 1.9-1.10

Installation dimensions

Drawer runner fixing positions

Minimum space required for the cabinet

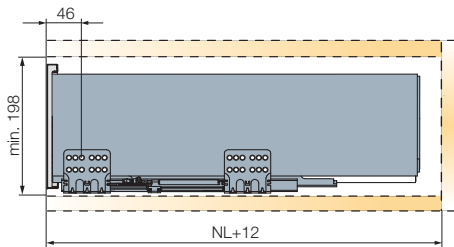

Cutting dimensions details

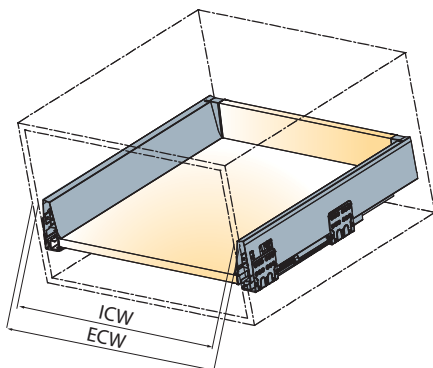

ECW: External cabinet width
ICW: Internal cabinet width
NL: Nominal length of drawer

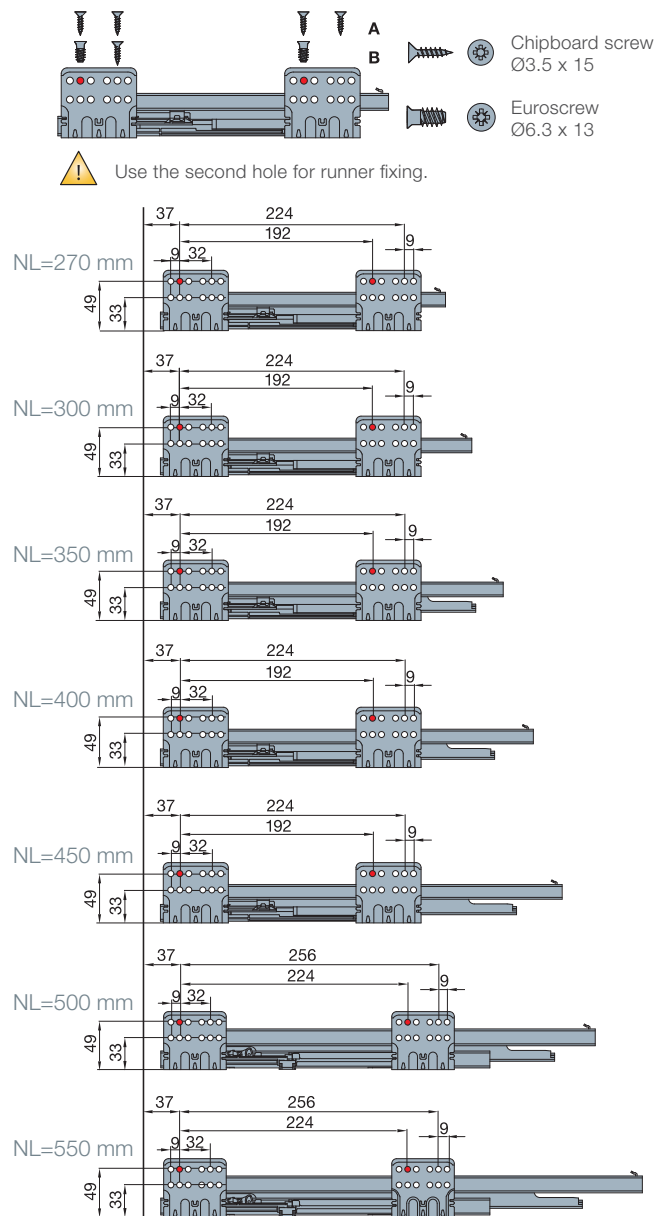

Inner Drawer Front for Tekform Slimline Drawer SDW145 with Glass

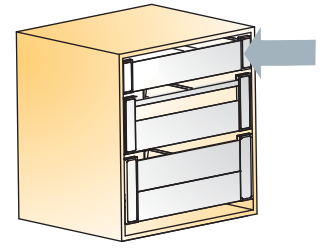

Inner Drawer Front, Assembly Set

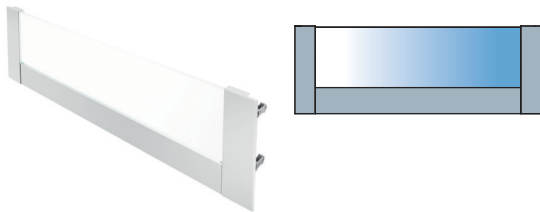

Made of aluminium and glass

Front Panel

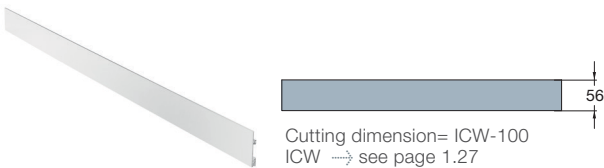

Made of aluminium

Front Glass Panel - High

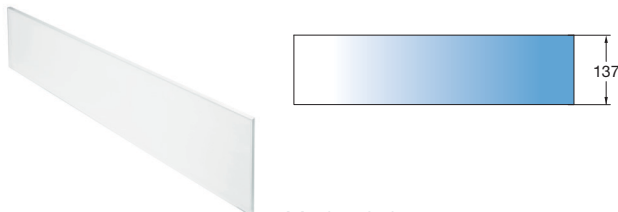

Made of glass

Front Bracket Set

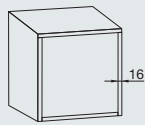

Made of aluminium and plastic

External cabinet width (mm)	Cabinet side thickness=16mm 	Cabinet side thickness=16mm			
		White	Anthracite grey	Frosted glass	Transparent glass
Item number					
600	655.8200 →	511.00	515.00		
600	655.8205 →	511.00	515.00		
1200	655.8209 →	511.00	515.00		
600	655.8220 →			391.00*	392.00
800*	655.8221 →			391.00	392.00
900*	655.8222 →			391.00	392.00
	655.8103 →	350.00	385.00		



Front panel support clip
002110.885.300 white

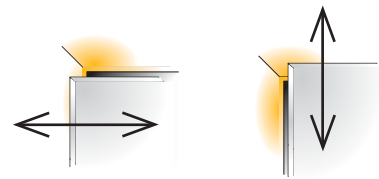
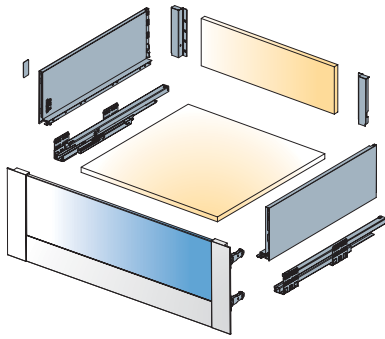

Side adjustment
+1/-1mm

Height adjustment
+2/-2mm

For further explanation → see page 1.9-1.10

Installation dimensions

Minimum space required for the cabinet

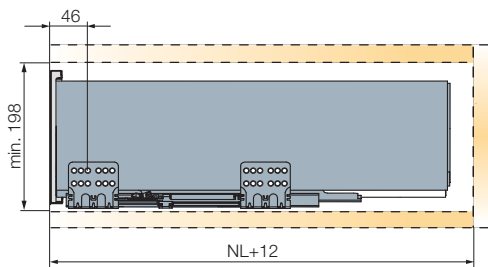

Cutting dimensions details

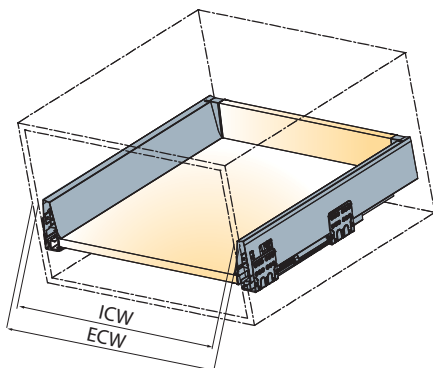

ECW: External cabinet width
ICW: Internal cabinet width
NL: Nominal length of drawer

Drawer runner fixing positions

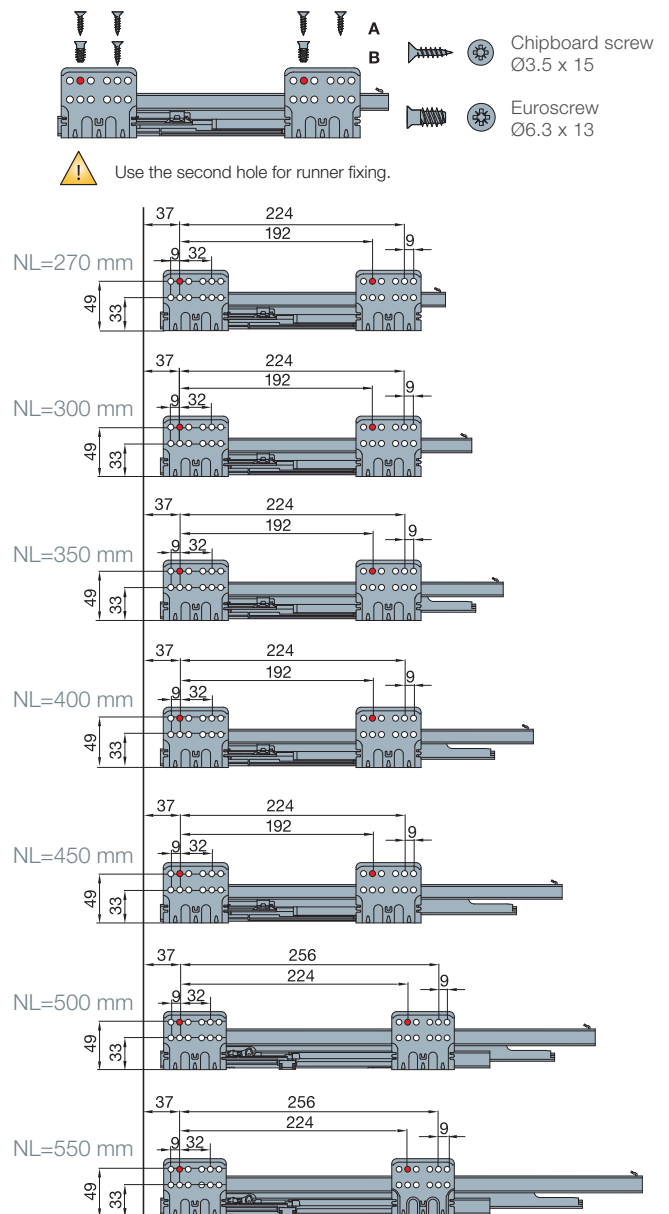

Inner Drawer Front for Tekform Slimline Drawer SDW182 with Bar

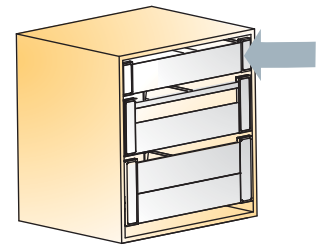

Inner Drawer Front, Assembly Set

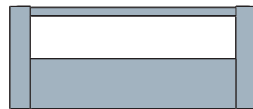

Made of aluminium and plastic

Front Bar

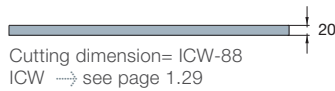

Made of aluminium

Front Panel

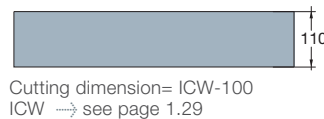
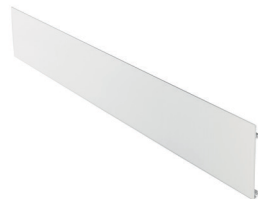

Made of aluminium

Front Bracket Set



Made of aluminium and plastic

External cabinet width (mm)	Cabinet side thickness=16mm			
	Item number		White	Anthracite grey
600	655.8260 →		511.00	515.00
1200	655.8264 →		511.00	515.00
600	655.8210 →		511.00	515.00
1200	655.8214 →		511.00	515.00
600	655.8185 →		511.00	515.00
1200	655.8189 →		511.00	515.00
	655.8170 →		350.00	385.00



Front panel support clip
002110.885.300 white

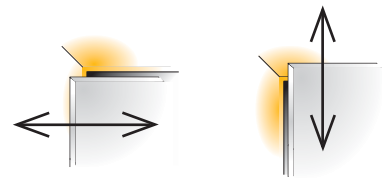
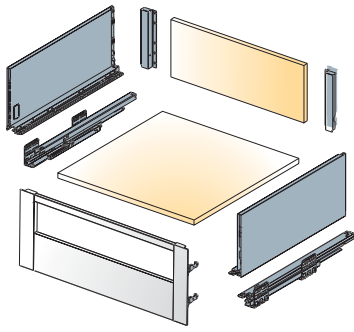

Side
adjustment
+1/-1mm

Height
adjustment
+2/-2mm

For further explanation → see page 1.9-1.10

Installation dimensions

Minimum space required for the cabinet

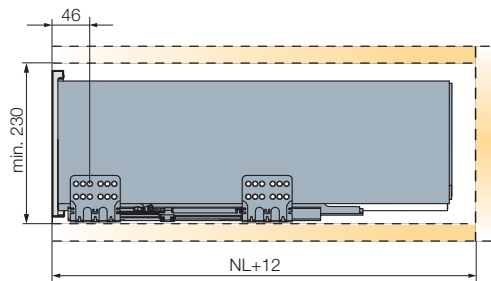

Cutting dimensions details

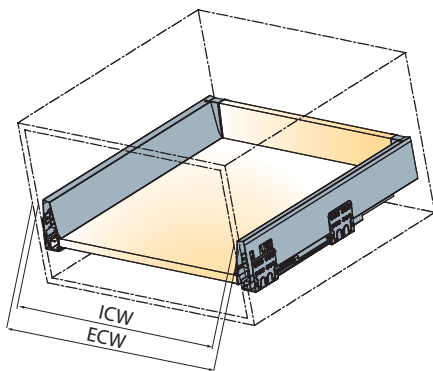

ECW: External cabinet width
ICW: Internal cabinet width
NL: Nominal length of drawer

Drawer runner fixing positions

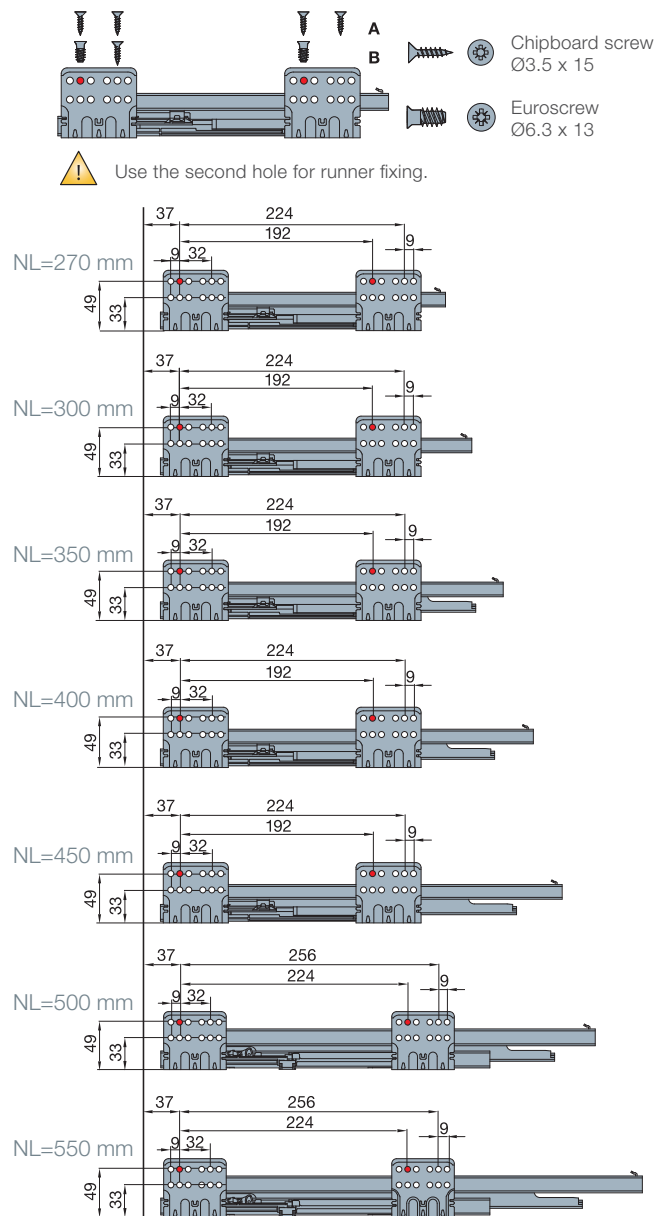

Inner Drawer Front for Tekform Slimline Drawer SDW182 with Glass

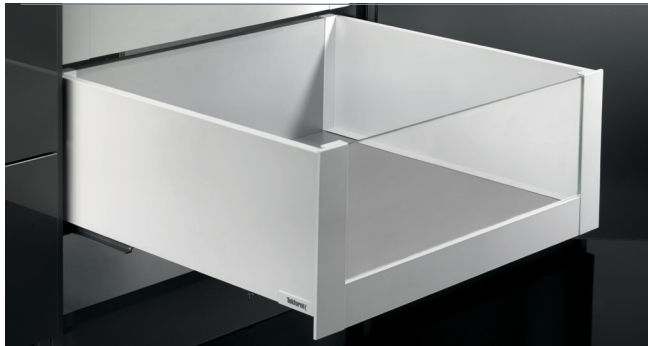
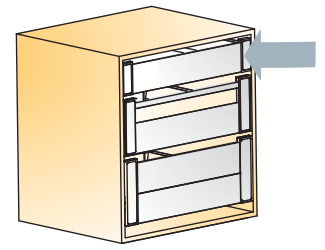

Inner Drawer Front, Assembly Set

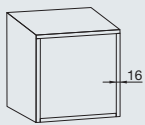
External cabinet width (mm)	Cabinet side thickness=16mm				
					
Item number		White	Anthracite grey	Frosted glass	Transparent glass

Made of aluminium and glass

Front Panel

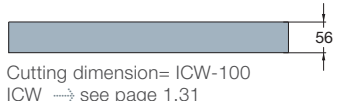

Cutting dimension= ICW-100
ICW → see page 1.31

Made of aluminium

600	655.8270 →	511.00	515.00		
-----	------------	--------	--------	--	--

Front Glass Panel - High



Made of glass

600	655.8205 →	511.00	515.00		
1200	655.8209 →	511.00	515.00		

600	655.8280 →			391.00*	392.00
800	655.8281 →			391.00*	392.00
900	655.8282 →			391.00*	392.00

Front Bracket Set



Made of aluminium and plastic

	655.8172 →	350.00	385.00		
--	------------	--------	--------	--	--



Front panel support clip
002110.885.300 white

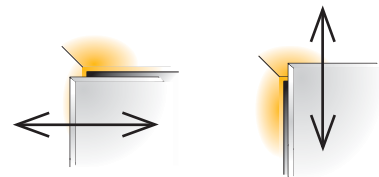
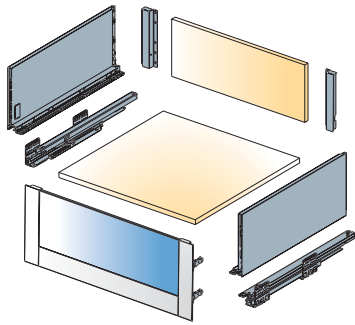

Side adjustment
+1/-1mm

Height adjustment
+2/-2mm

For further explanation → see page 1.9-1.10

Installation dimensions

Drawer runner fixing positions

Minimum space required for the cabinet

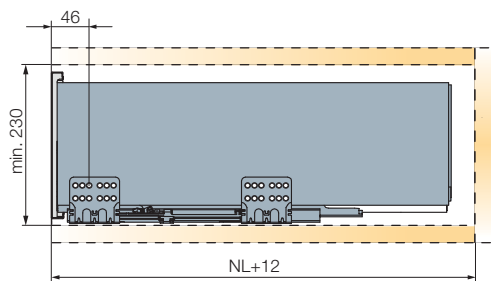

Cutting dimensions details

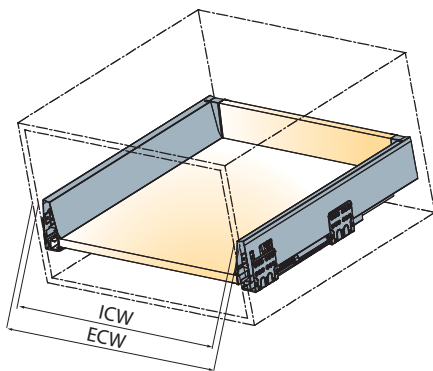

ECW: External cabinet width
ICW: Internal cabinet width
NL: Nominal length of drawer

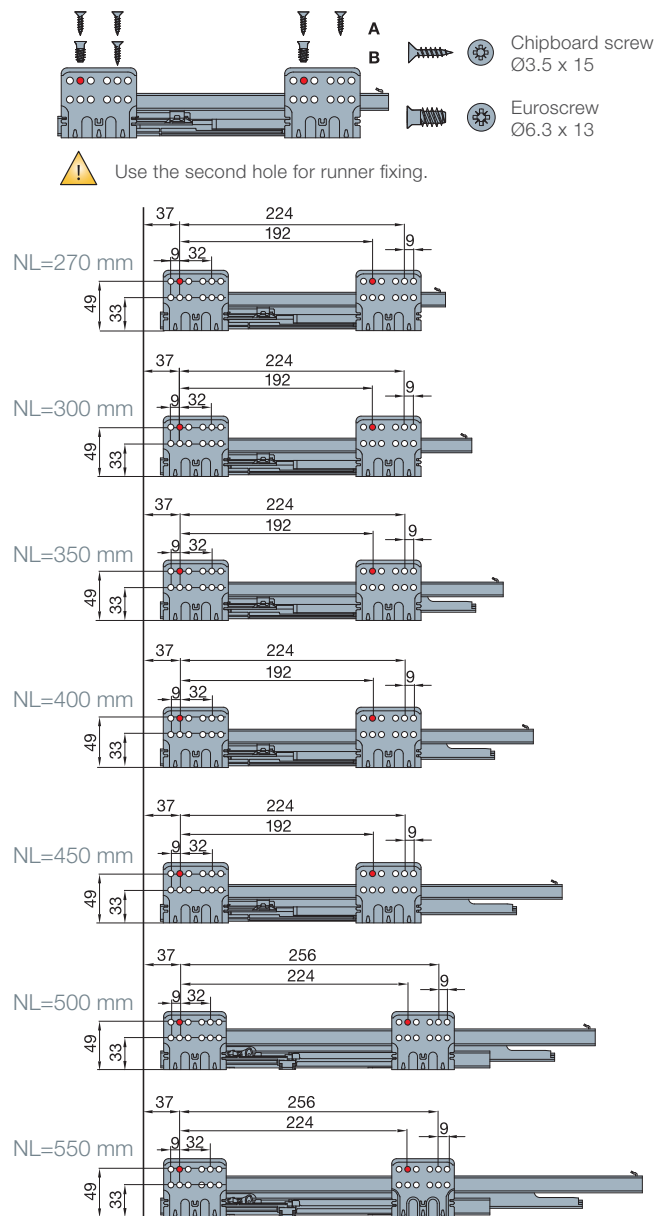

Assembly Instructions



Screws not included

Assembly Sequence

Connect the drawer sides to the bottom panel (1) and fix it with screws (2)

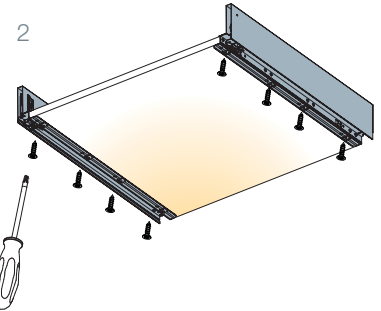
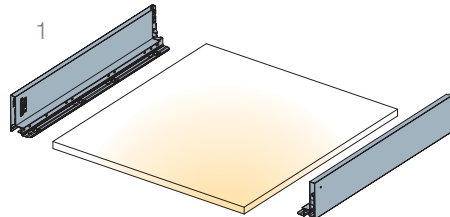

Chipboard screw
Ø3.5 x 15

Insert the rear connector vertically (3) and push it downwards into recess in the drawer side (4)

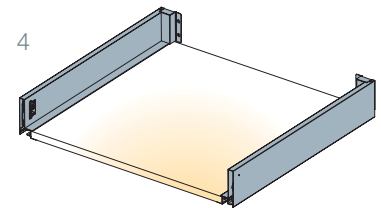
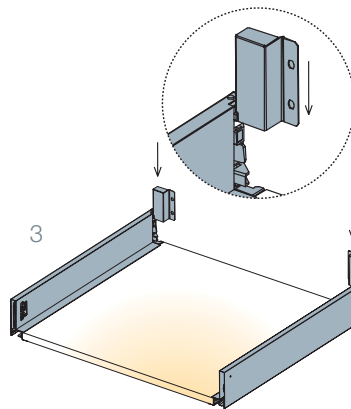

Insert the back panel (5) and fix it with screws (6)

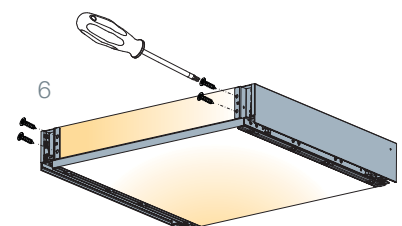
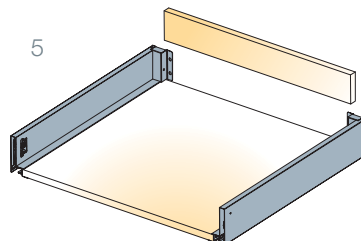

Chipboard screw
Ø3.5 x 15



Screws not included

Insertion of Front Connectors

EasyFix

Insert the front connectors into holes on the front panel

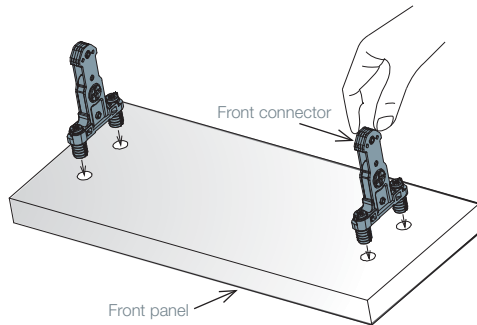

Turn the screws 90° into locked position

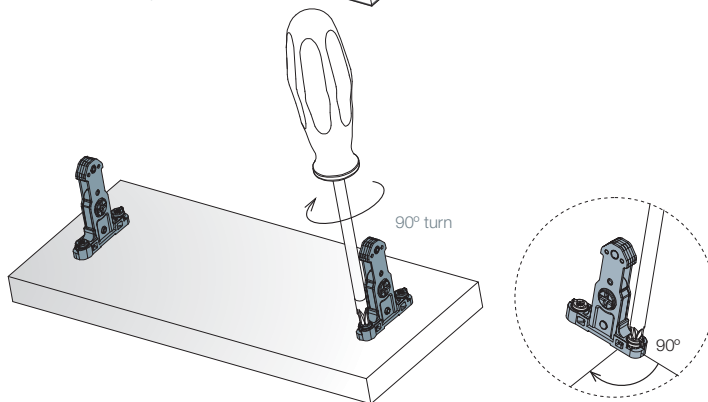

Screw-in fixing

Use Ø3.5 x 15mm screws for fixing

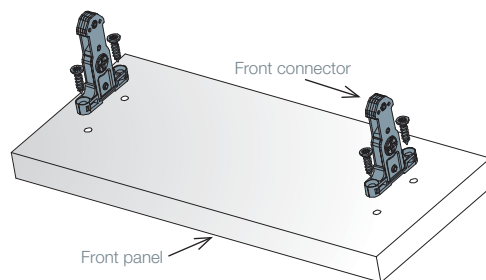

 Chipboard screw
Ø3.5 x 15

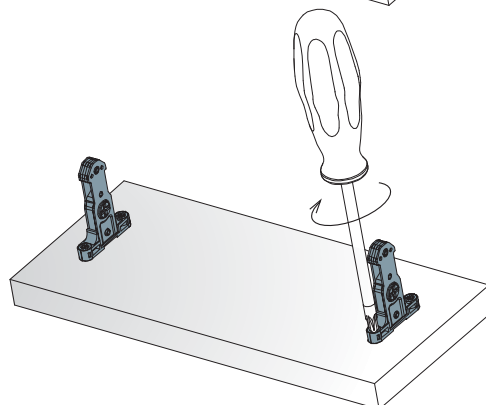

Assembly Instructions

Front Panel Mounting / Removal

Mounting

Attach the front panel to the drawer and press to click

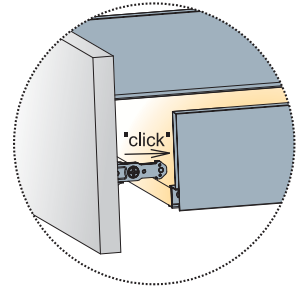
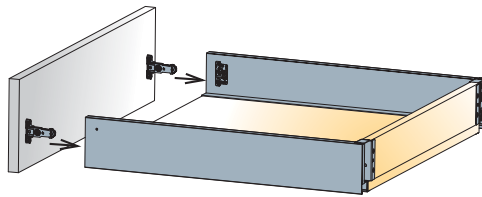

Removal

Turn the screw towards the front panel

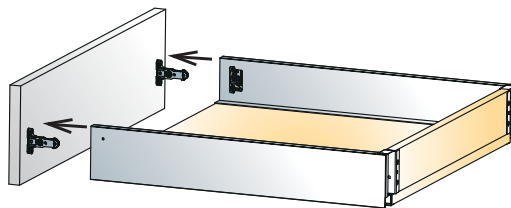
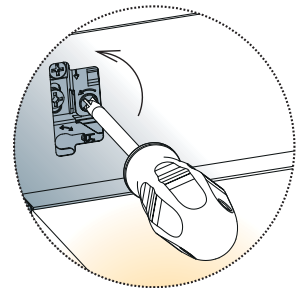
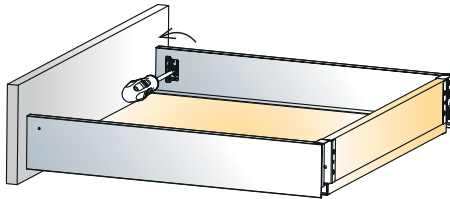



Screws not included

Draw Insertion / Removal

Insertion

Place the drawer horizontally on the runners and push towards the cabinet until you hear the drawer is locked

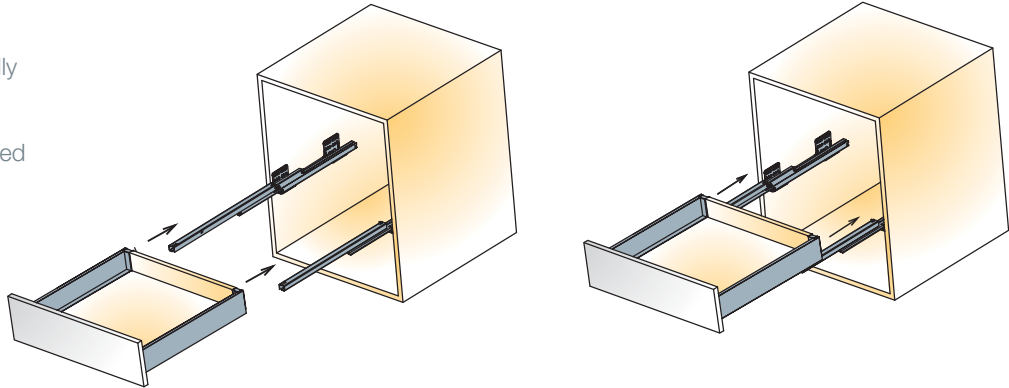

Push to fully close until drawer clicks. Pull drawer out and push to fully close again until drawer clicks twice

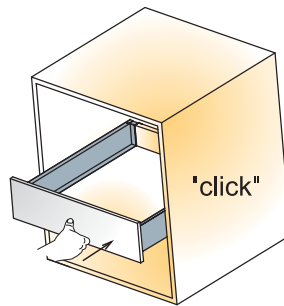

Removal

Press-up the button under the drawer. Keep pressed to pull the drawer out

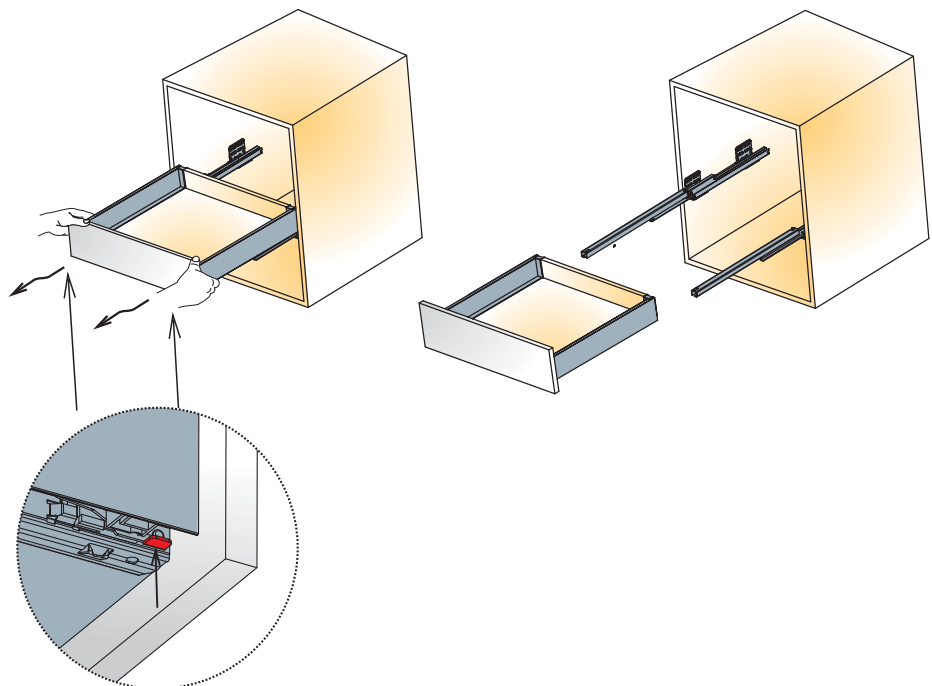

Press-up

Tekform Drawer

Product Guide

Tekform Drawer

Page

Tekform Drawer DW70

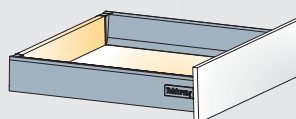

1.46

Tekform Drawer DW113

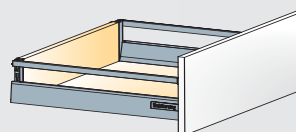

1.48

Tekform Drawer DW145

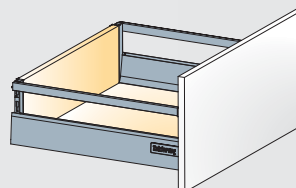

1.50

Tekform Drawer DW182

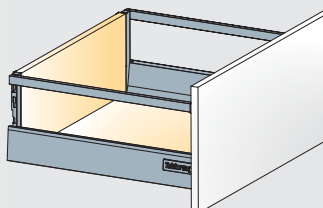

1.52

Inner Drawer Fronts

For DW70

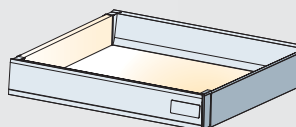

1.56

For DW145 with
Square Bar

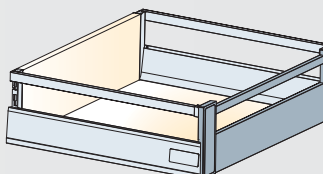

1.58

For DW182 with
Square Bar

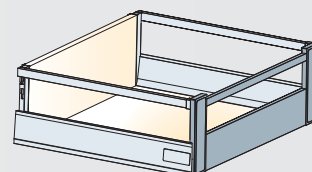

1.60

Accessories

Glass Sides 4mm

1.62

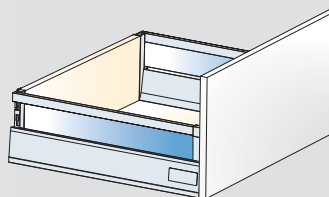

Glass Sides 8mm

1.63

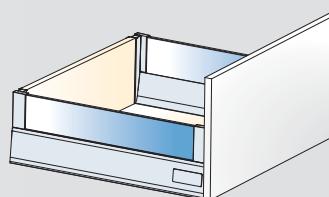

Industrial Packaging

1.54

Drawer Storage System

1.64

Assembly and Mounting

1.65

Tekform Double Wall Drawer



'EasyFix' front panel connector

- Hand insertion
- Quarter turn lock
- Repeatable assembly and disassembly possible

User friendly mounting

- Intuitive installation instructions
- Easy assembly and disassembly of the drawer

Superior vertical and horizontal stability of rails

- Smooth and silent operation
- Reliable drawer opening and closing
- Improved drawer stability in open position

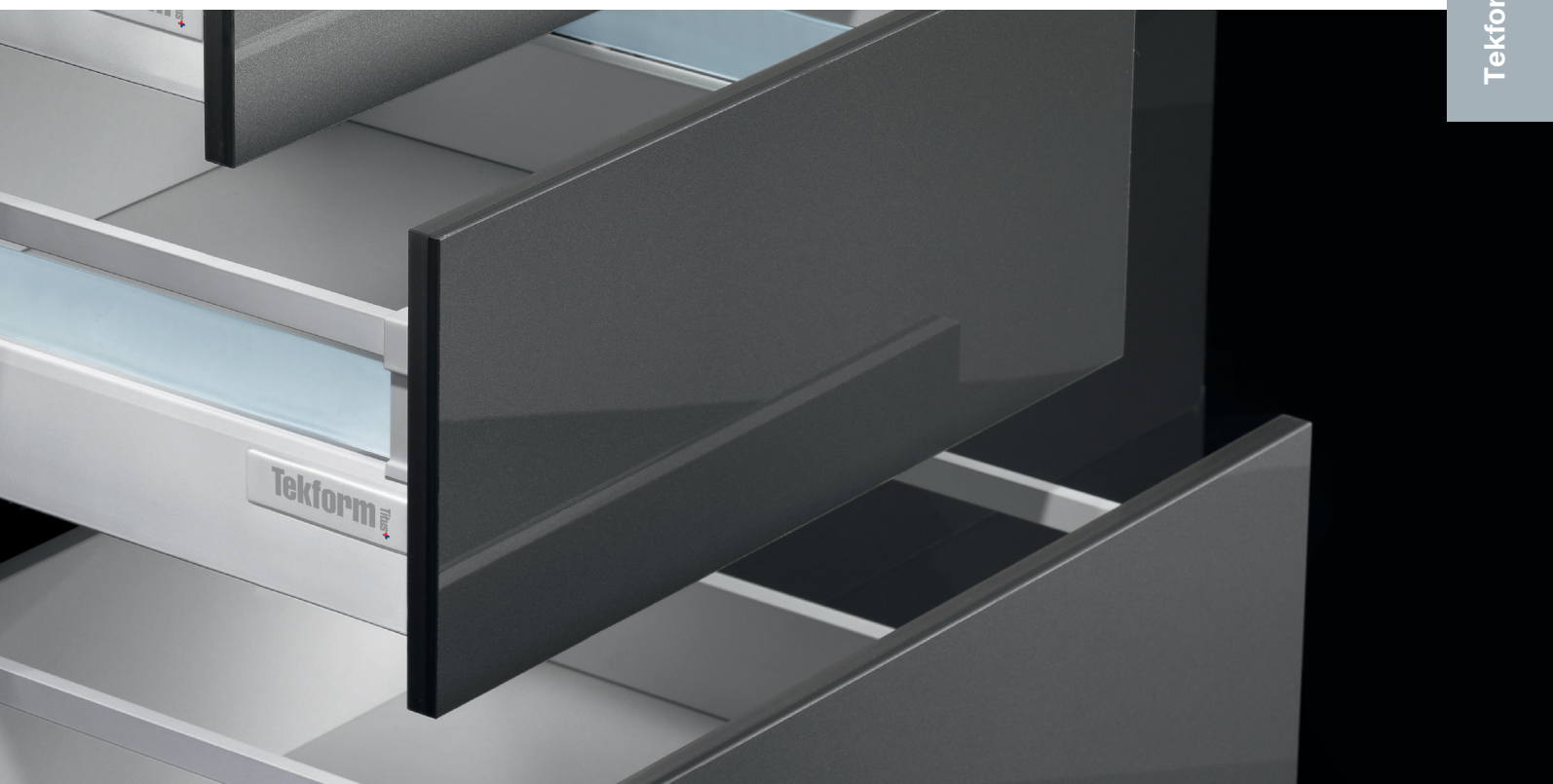

Precise drawer alignment

- Tekform Drawer provides a +/- 1mm tolerance on drawer bottom width
- Intuitive drawer front adjustment

Integrated Titus damper

- Life-long reliable closing
- Consistent damping at various closing speeds
- Consumer-preferred 'ConfidentClose'

Quality certified

- By European specialised institutions

Tekform Drawer Information

Technical Guide

How to choose the appropriate drawer dimension?

Select Tekform Drawer size based on available cabinet space. Please refer to the below chart with indicated minimum

space required in cabinet to choose appropriate drawer system.

Tekform Drawer nominal length (NL) in mm:

NL	270	300	350	400	450	500	550
	Tekform Drawer			Tekform Drawer with inner front			
	Min. height (H) required	Cabinet depth (D)	Min. height (H) required	Cabinet depth (D)			
Tekform Drawer DW70	105mm	NL+min 3mm	115mm	NL+min 12mm			
Tekform Drawer DW113	160mm	NL+min 3mm	NA	NA			
Tekform Drawer DW145	185mm	NL+min 3mm	193mm	NL+min 12mm			
Tekform Drawer DW182	224mm	NL+min 3mm	224mm	NL+min 12mm			

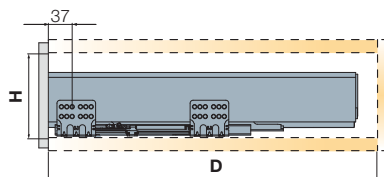

How to fix drawer sides to the front panel?

The Tekform Drawer is available with 'EasyFix' or screw-in front connectors.



'EasyFix' front connector

- Hand insertion
- Quarter turn locking system
- Expandable plastic dowel
- Easy assembly and disassembly of front panel



Screw-in front connector

- Reliable connection
- Fixing with Ø3.5x15mm screw (screws are not included)

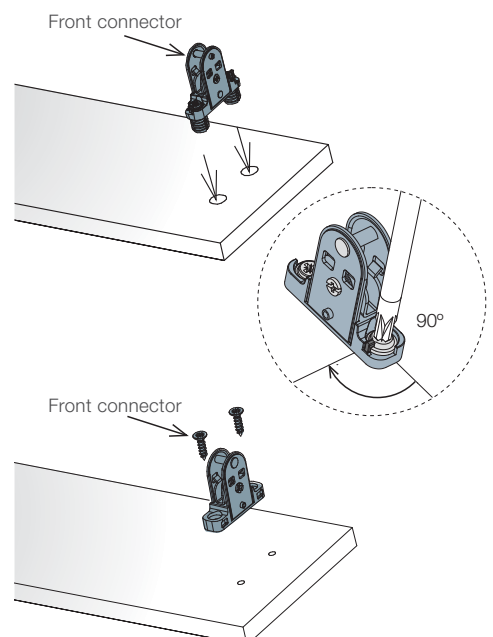

Technical Guide

Bottom panel and back panel cutting dimensions

Dimensions of bottom and back panel depends on:

- Cabinet width
- Nominal drawer length
- Drawer height

Tekform Drawer nominal length (NL) in mm:

NL	270	300	350	400	450	500	550
----	-----	-----	-----	-----	-----	-----	-----

Cabinet width

ECW: External cabinet width
 ICW: Internal cabinet width
 NL: Nominal length of drawer

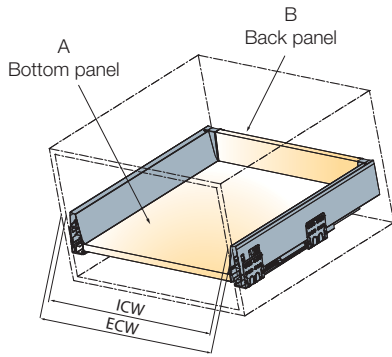

Back panel cutting dimension

Back panel height depends on the selected drawer height.

	H back panel
DW70	68
DW113	119
DW145	151
DW182	183

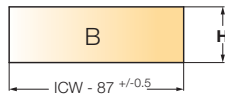

Bottom panel cutting dimensions

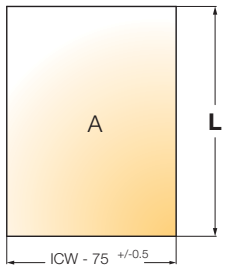

NL	270	300	350	400	450	500	550
L	260	290	340	390	440	490	540

NL= Tekform Drawer nominal length (in mm)

Tekform Drawer Information

Technical Guide

How to choose the appropriate drawer runner fixing positions?

Drawer fixing positions depend on the drawer front type.

Tekform Drawer with standard front

When a standard drawer front is applied, use the third hole on the drawer runner for fixing.

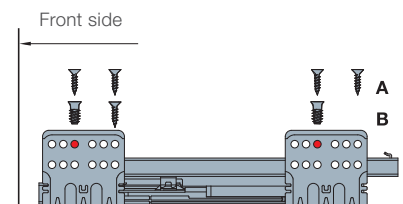

Tekform Drawer with inner front

When an inner drawer front is applied, use the second hole on the drawer runner for fixing.

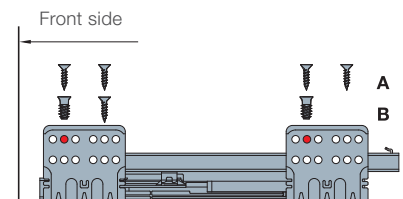

Load capacity

Tekform Drawer load capacity is 40kg.

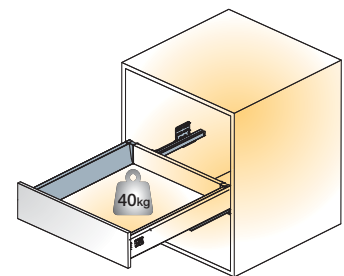

Expanded tolerances

Tekform Drawer provides expanded tolerances in cabinet construction and enables:

- Precise drawer alignment
- Smooth and silent operation
- Improved drawer stability in open position
- Tolerance of +/- 1mm on bottom panel width size

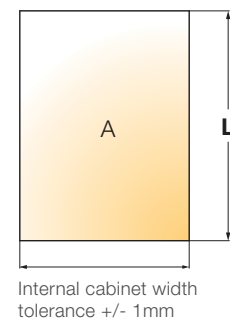



Adjustment needs to be done on both sides of the drawer

Adjustments

Side adjustment

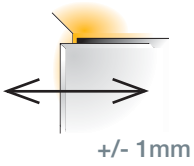

Side adjustment is done via the adjustment screw on the drawer side. Tighten screw to adjust.

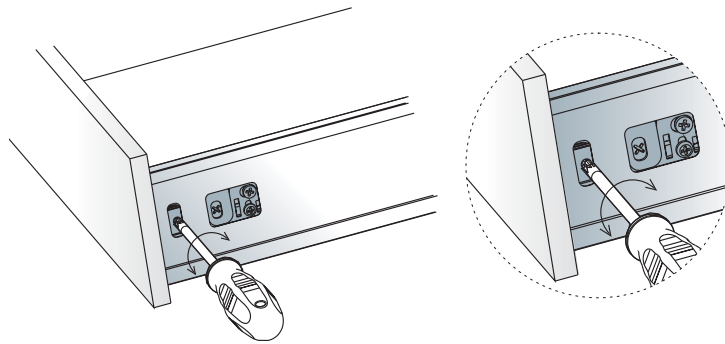

Height adjustment

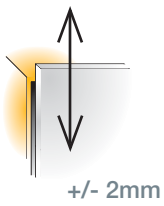

Height adjustment is done via the cam. Release the locking screw and tighten it back after the front is adjusted.

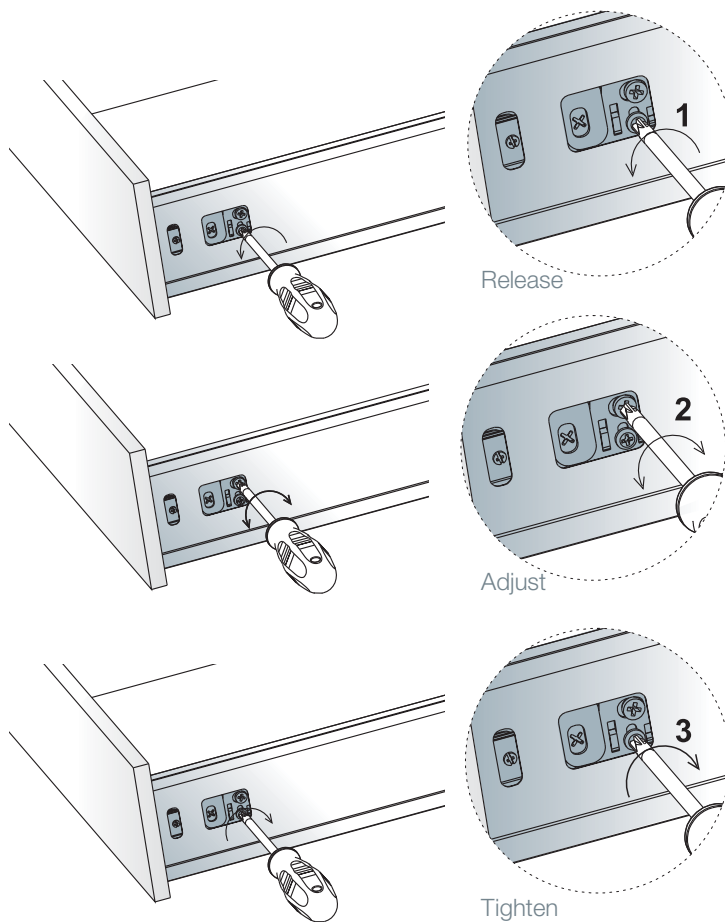

Tekform Drawer Information



Adjustment needs to be done on both sides of the drawer

Adjustments

Depth adjustment



+/- 2mm

Depth adjustment is done through the connecting bar.

Please note: connecting bars can't be used with the 8mm thick glass sides.

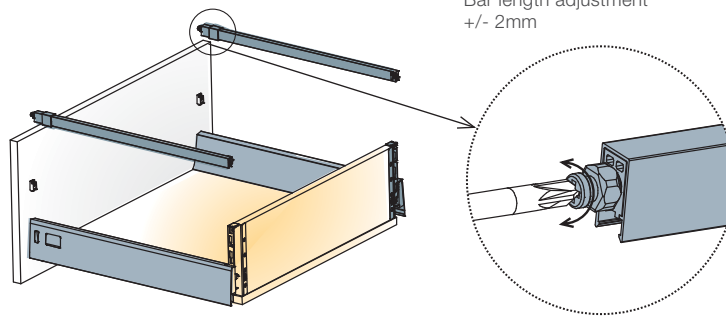

Bar length adjustment
+/- 2mm

Key Design Choices

'ConfidentClose'

Fast closing

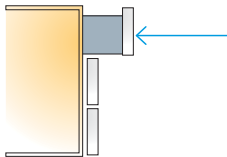

Late start of deceleration action

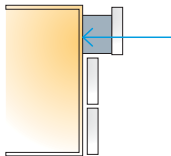

Quiet landing

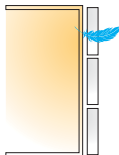

CAF Consumer Assembly Friendliness

'EasyFix' front panel connector with expandable plastic dowel provides:

- Quick, tool-free insertion
- Quarter turn lock
- Repeatable assembly and disassembly

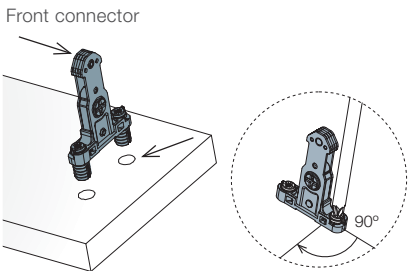

Titus hydraulic damper

Designed and produced in-house.

- Reliable and consistent life-long damping
- Smooth closing
- Dampers' consistency over high volume production runs assured
- 100% automated quality check



Damping action

Even and smooth soft closing action.

- Soft and reliable closing

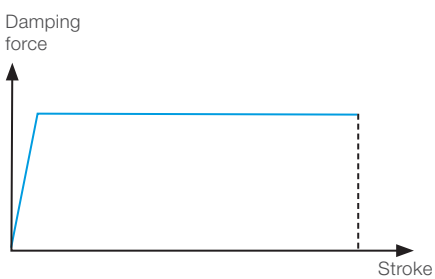

Flat damping curve shows the uniform action produced during damper closing at a defined speed.

Tekform Drawer DW70

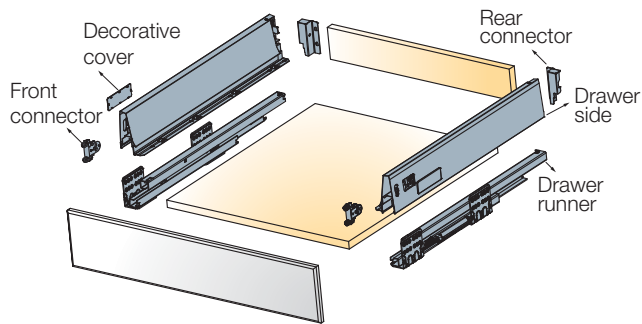
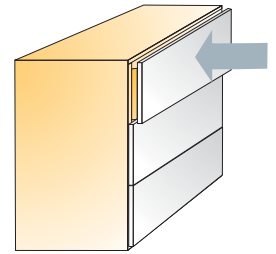

Cutting dimensions details

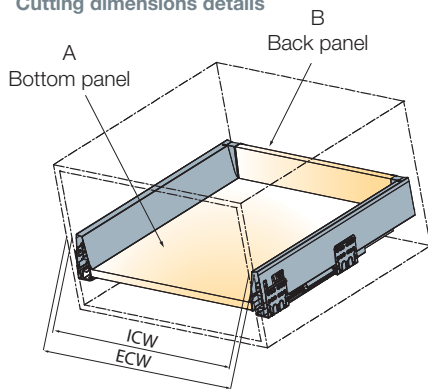

ECW: External cabinet width
 ICW: Internal cabinet width
 NL: Nominal length of drawer

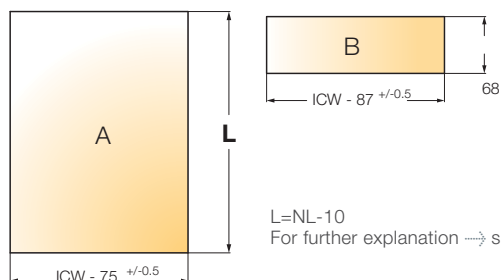

Nominal length (mm)	with EasyFix front connector 		
		White	Anthracite grey
270	Item number for a set 650.8027 →	150	185*
300*	650.8030 →	150	185*
350	650.8035 →	150	185*
400	650.8040 →	150	185*
450	650.8045 →	150	185*
500	650.8050 →	150	185*
550	650.8055 →	150	185*

Assembly instructions → see page 1.65

**Supplied with EasyFix connectors. Order Screw-in connectors separately → 650.8905.380
 Screws not included

- Drawer runner type
- Load capacity
- Minimum height space required
- Wooden back panel thickness
- Wooden bottom panel thickness

Full extension
40kg
105mm
16mm
16mm

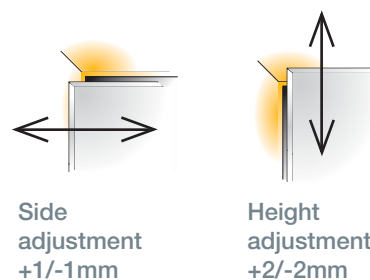

For further explanation → see page 1.43-1.44

Installation dimensions

Minimum space required for the cabinet

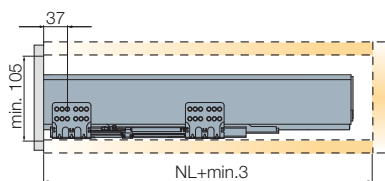

Drilling dimensions for the front panel

EasyFix attachment

Screw-in attachment

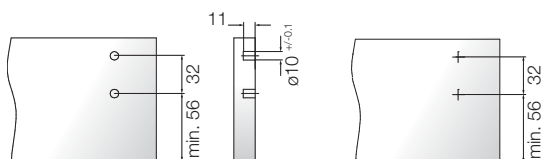

Mounting dimensions for the back panel

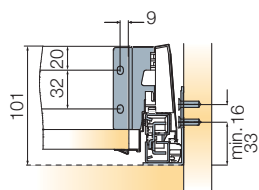

Installation dimensions for the front panel

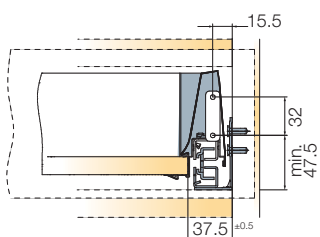

Drawer runner fixing positions

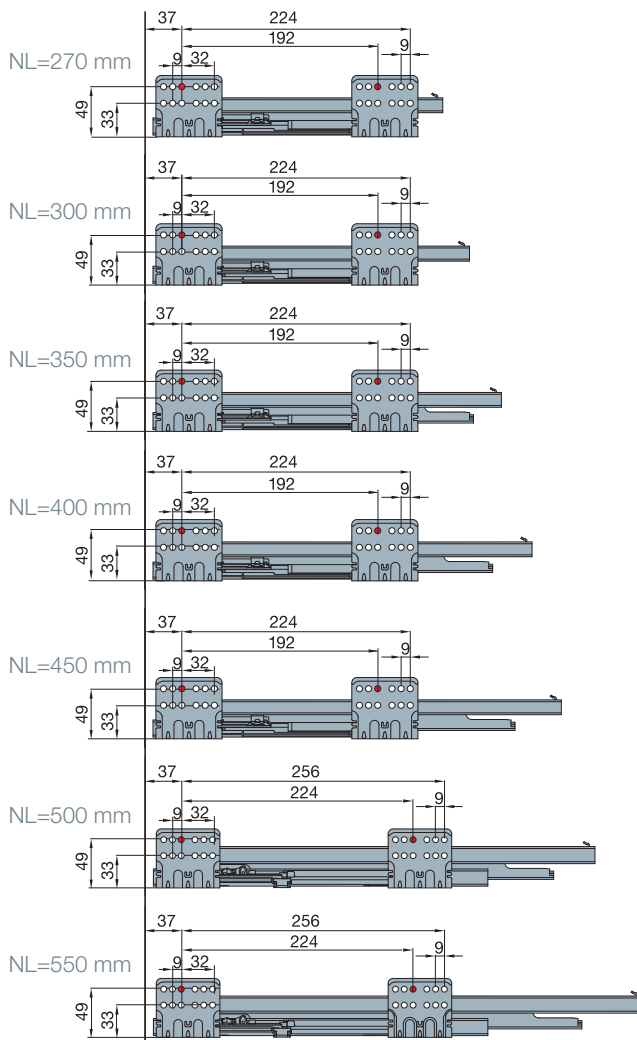
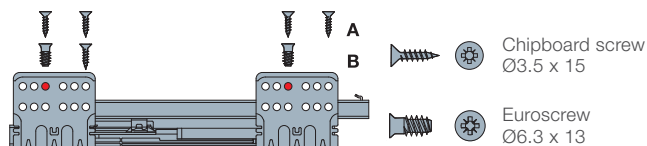

A trial mounting is always recommended. For further information please contact Titus Tekform.

Tekform Drawer DW113

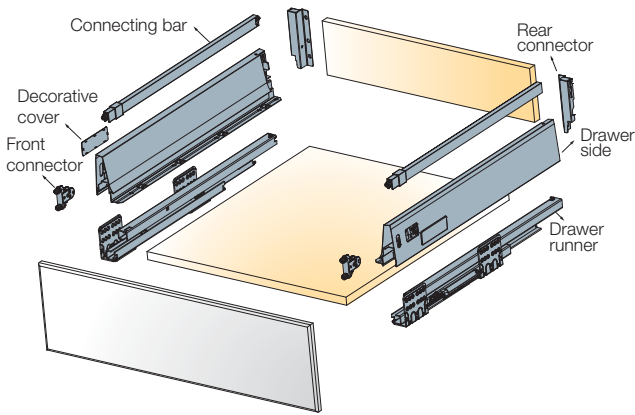
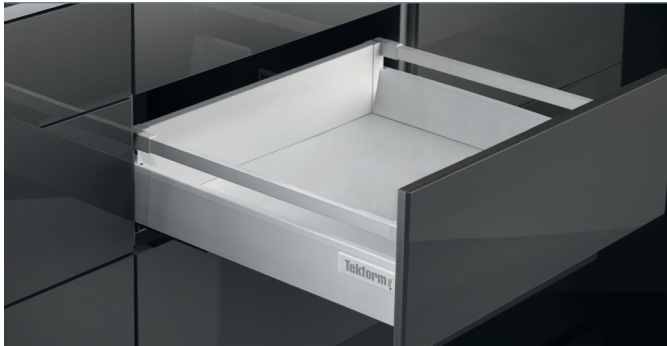
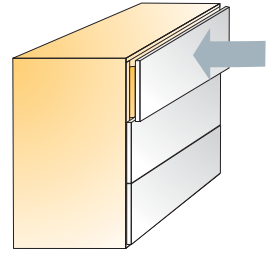

Cutting dimensions details

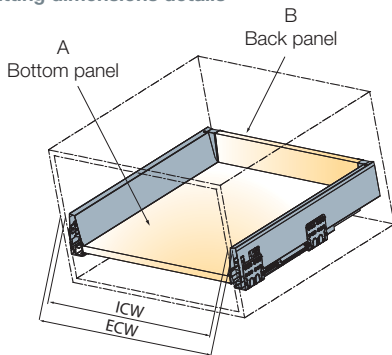

ECW: External cabinet width
 ICW: Internal cabinet width
 NL: Nominal length of drawer

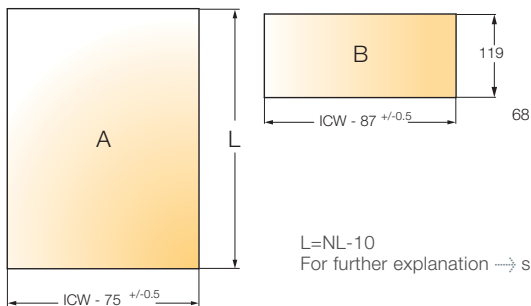

with EasyFix front connector

Nominal length (mm)

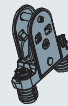

Item number for a set (DW70 + Bracket + Square Bar)

270	650.8027.150 +	650.8911.150 +	650.8727.150
350	650.8035.150 +	650.8911.150 +	650.8735.150
400	650.8040.150 +	650.8911.150 +	650.8740.150
450	650.8045.150 +	650.8911.150 +	650.8745.150
500	650.8050.150 +	650.8911.150 +	650.8750.150
550	650.8055.150 +	650.8911.150 +	650.8755.150

* Available upon special request
 Assembly instructions → see page 1.65

**Supplied with EasyFix connectors. Order Screw-in connectors separately → 650.8905.380
 Screws not included

- Drawer runner type
- Load capacity
- Minimum height space required
- Wooden back panel thickness
- Wooden bottom panel thickness

Full extension
40kg
160mm
16mm
16mm

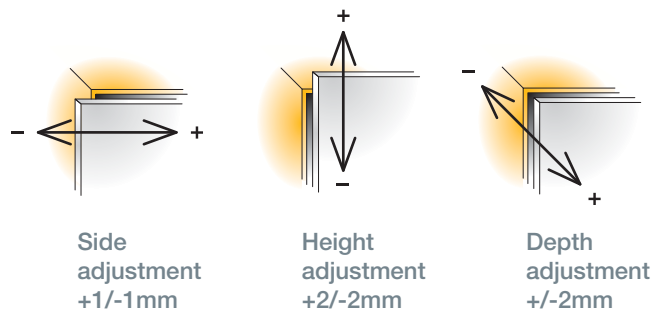

For further explanation → see page 1.43-1.44

Installation dimensions

Minimum space required for the cabinet

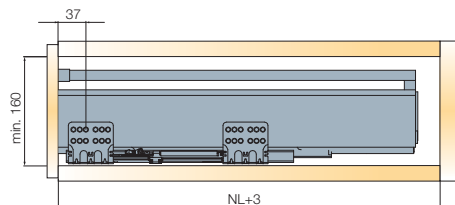

Drilling dimensions for the front panel

EasyFix attachment

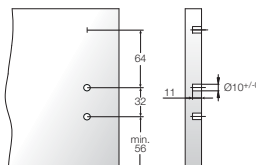

Mounting dimensions for the back panel

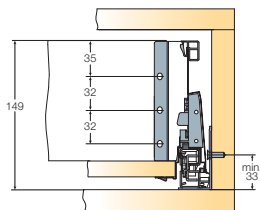

Installation dimensions for the front panel

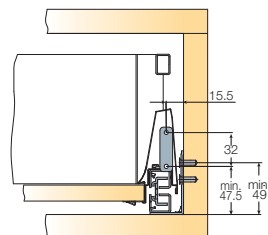

Drawer runner fixing positions

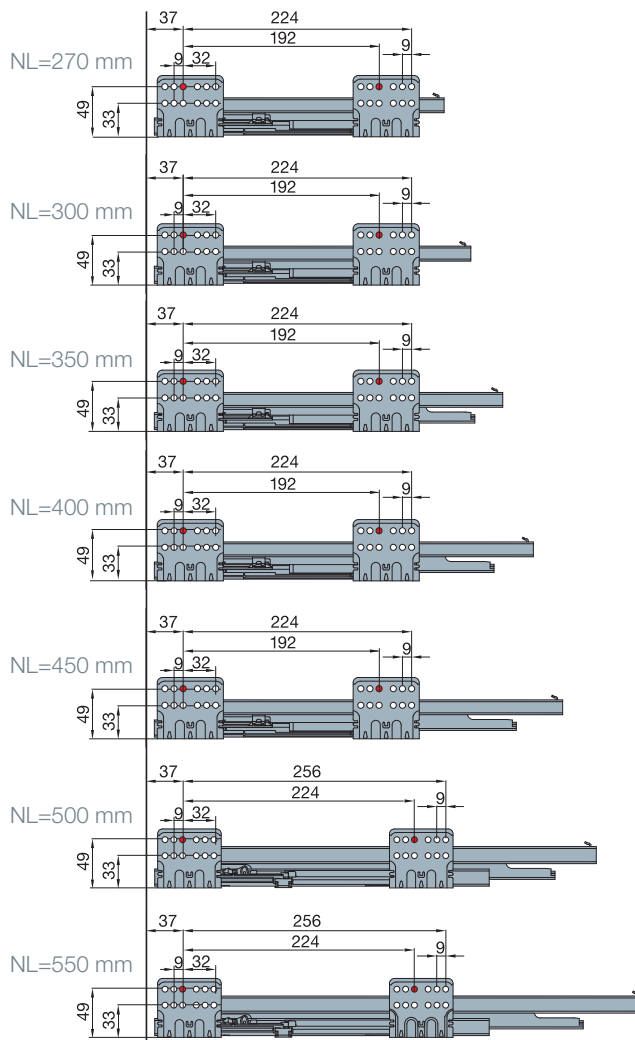
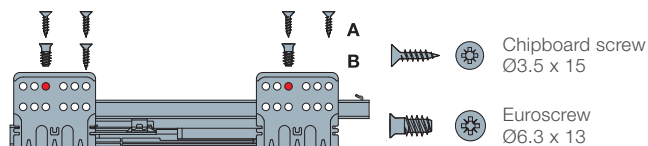

A trial mounting is always recommended. For further information please contact Titus Tekform.

Tekform Drawer DW145

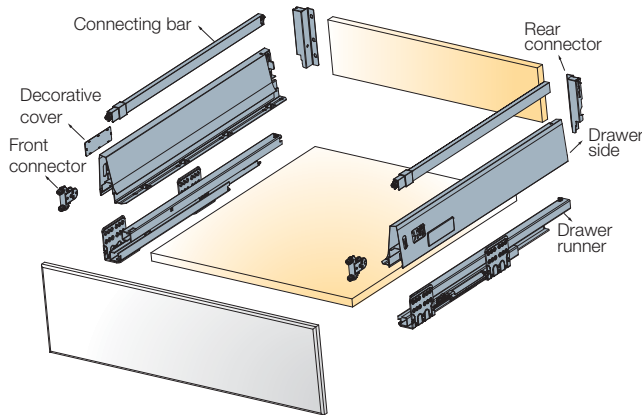
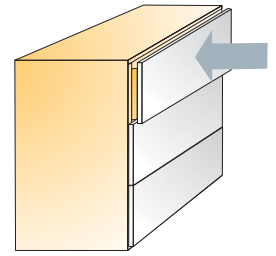



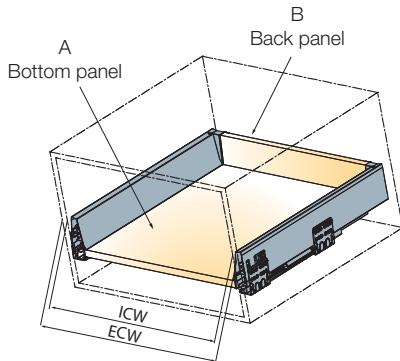

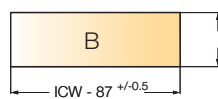
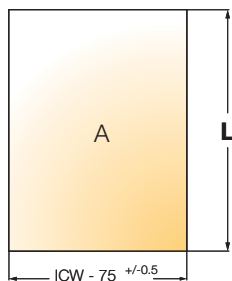

Cutting dimensions details

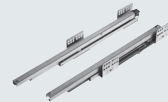

ECW: External cabinet width
 ICW: Internal cabinet width
 NL: Nominal length of drawer



L = NL - 10
 For further explanation → see page 1.41

Nominal length (mm)	with EasyFix front connector			
	Item number for a set		White	Anthracite grey
270	650.8127 →		150K	185*
300*	650.8130 →		150K	185*
350	650.8135 →		150K	185*
400	650.8140 →		150K	185*
450	650.8145 →		150K	185*
500	650.8150 →		150K	185*
550	650.8155 →		150K	185*
Assembly instructions → see page 1.65				
One set consists of				
Drawer sides				2 pcs
Drawer runner				2 pcs
Connecting bars				2 pcs
*Front connectors				2 pcs
Rear connectors				2 pcs
Decorative covers				2 pcs
Mounting instructions				1 pce

**Supplied with EasyFix connectors. Order Screw-in connectors separately → 650.8905.380
 Screws not included

- Drawer runner type
- Load capacity
- Minimum height space required
- Wooden back panel thickness
- Wooden bottom panel thickness

Full extension
40kg
185mm
16mm
16mm

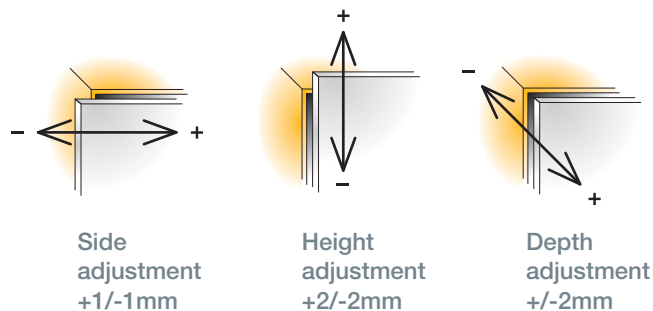

For further explanation → see page 1.43-1.44

Installation dimensions

Minimum space required for the cabinet

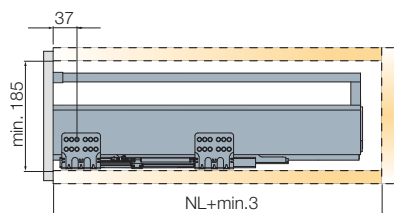

Drilling dimensions for the front panel

EasyFix attachment

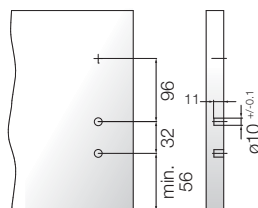

Screw-in attachment

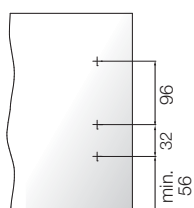

Mounting dimensions for the back panel

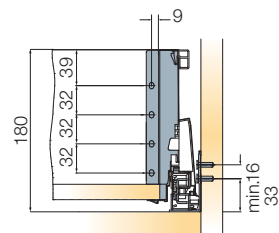

Installation dimensions for the front panel

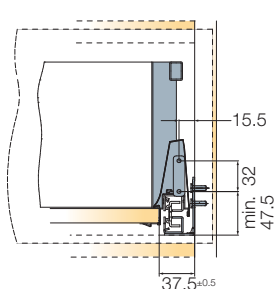

Drawer runner fixing positions

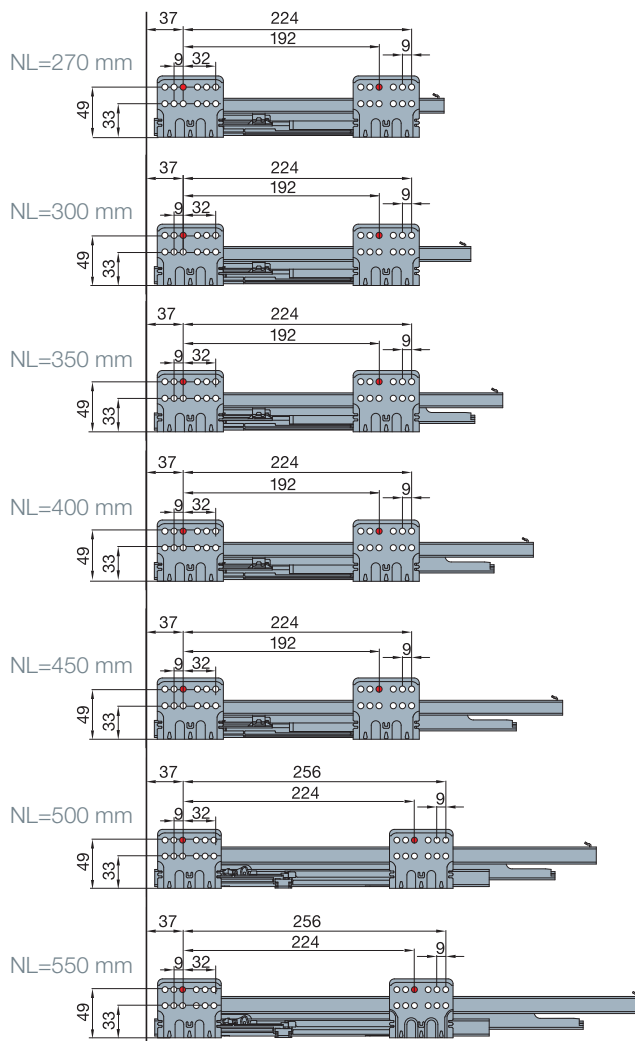
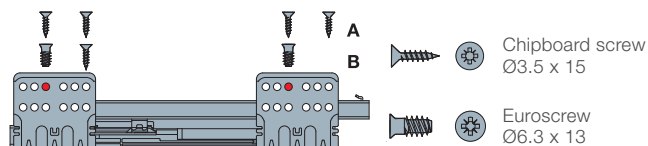

A trial mounting is always recommended. For further information please contact Titus Tekform.

Tekform Drawer DW182

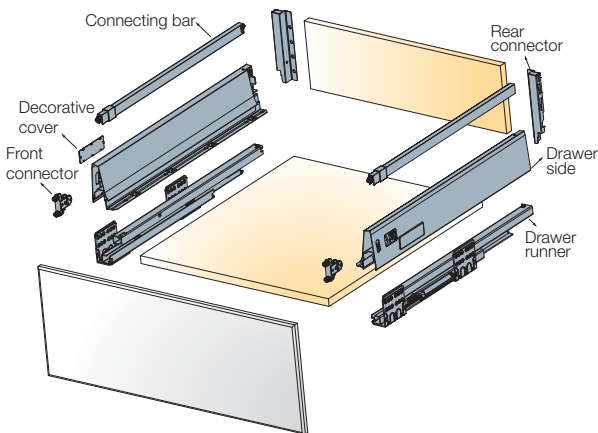
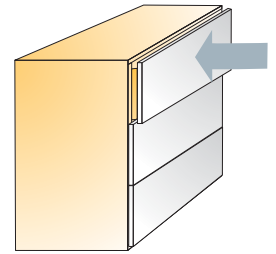

Cutting dimensions details

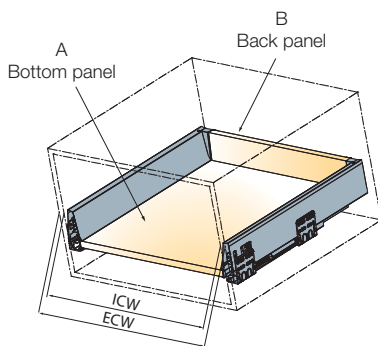

ECW: External cabinet width
 ICW: Internal cabinet width
 NL: Nominal length of drawer

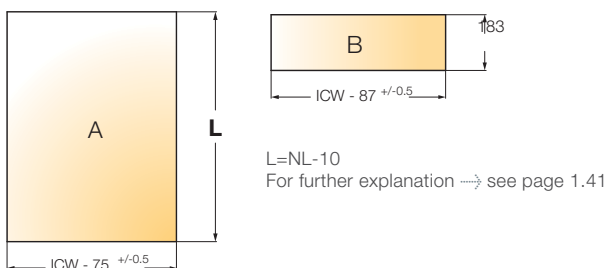

Nominal length (mm)	with EasyFix front connector		with Screw-in front connector	
	Item number for a set	White	Anthracite grey	
270	650.8227 →	150K	185*	
300*	650.8230 →	150K	185*	
350	650.8235 →	150K	185*	
400	650.8240 →	150K	185*	
450	650.8245 →	150K	185*	
500	650.8250 →	150K	185*	
550	650.8255 →	150K	185*	
Assembly instructions → see page 1.65				
One set consists of				
Drawer sides		2 pcs		
Drawer runner		2 pcs		
Connecting bars		2 pcs		
*Front connectors		2 pcs		
Rear connectors		2 pcs		
Decorative covers		2 pcs		
Mounting instructions		1 pce		

**Supplied with EasyFix connectors. Order Screw-in connectors separately → 650.8905.380
 Screws not included

- Drawer runner type
- Load capacity
- Minimum height space required
- Wooden back panel thickness
- Wooden bottom panel thickness

Full extension
40kg
224mm
16mm
16mm

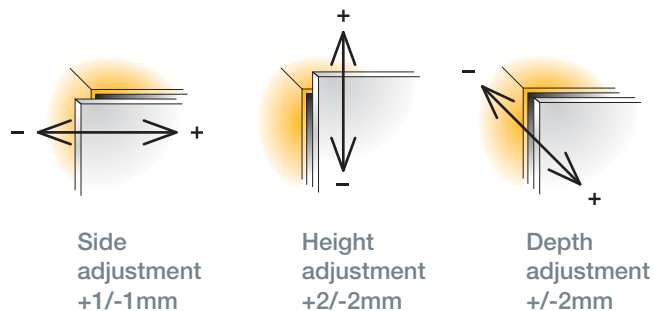

For further explanation → see page 1.43-1.44

Installation dimensions

Minimum space required for the cabinet

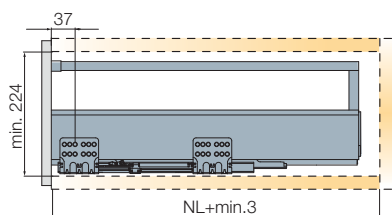

Drilling dimensions for the front panel

EasyFix attachment

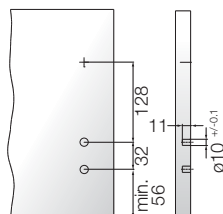

Screw-in attachment

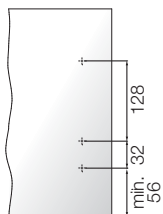

Mounting dimensions for the back panel

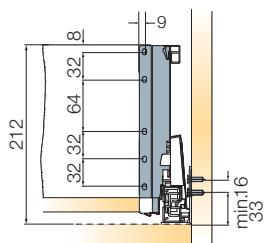

Installation dimensions for the front panel

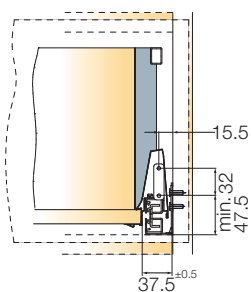

Drawer runner fixing positions

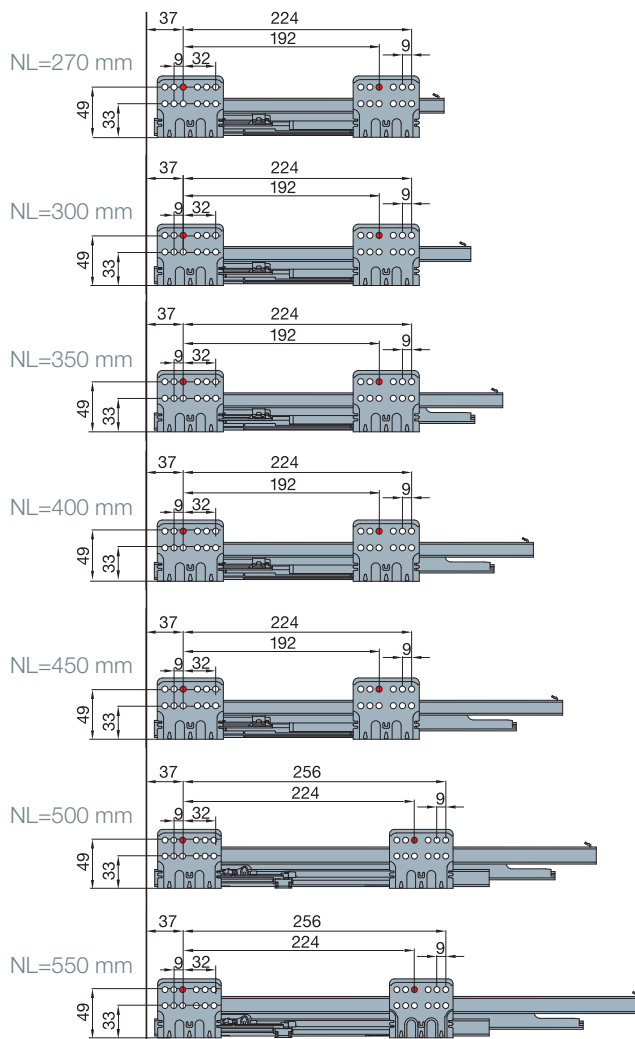
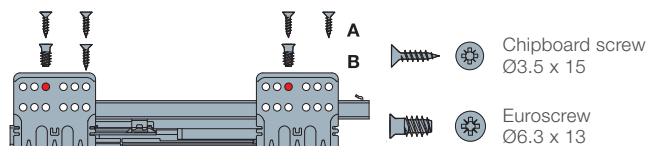

A trial mounting is always recommended. For further information please contact Titus Tekform.

Tekform Drawer Industrial Packaging

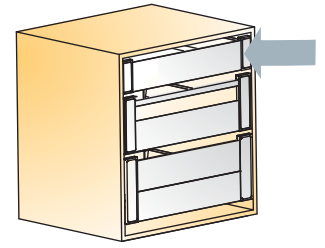

Drawer Runner



Drawer Side



	External cabinet width (mm)	Item number	Finish			
			Zinc plated	White	Anthracite grey	
Left	270*	660.8A27 →	040			
	300*	660.8A30 →	040			
	350*	660.8A35 →	040			
	400*	660.8A40 →	040			
	450*	660.8A45 →	040			
	500	660.8A50 →	040			
	550*	660.8A55 →	040			
	Right	270*	660.8B27 →	040		
		300*	660.8B30 →	040		
		350*	660.8B35 →	040		
		400*	660.8B40 →	040		
		450*	660.8B45 →	040		
		500	660.8B50 →	040		
		550*	660.8B55 →	040		
Left	270*	660.8C27 →		150	185*	
	300*	660.8C30 →		150	185*	
	350*	660.8C35 →		150	185*	
	400*	660.8C40 →		150	185*	
	450*	660.8C45 →		150	185*	
	500	660.8C50 →		150	185*	
	550*	660.8C55 →		150	185*	
	Right	270*	660.8D27 →		150	185*
		300*	660.8D30 →		150	185*
		350*	660.8D35 →		150	185*
		400*	660.8D40 →		150	185*
		450*	660.8D45 →		150	185*
		500	660.8D50 →		150	185*
		550*	660.8D55 →		150	185*

Assembly instructions > see page 1.65
Installation dimensions and Drawer runner fixing positions → see pages 1.47, 1.49 or 1.51

- Drawer runner type
- Load capacity
- Minimum height space required
- Wooden back panel thickness
- Wooden bottom panel thickness

Full extension
40kg
224mm
16mm
16mm

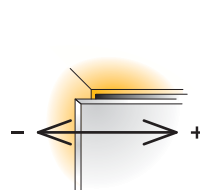

Side adjustment
+1/-1mm

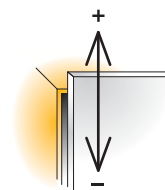

Height adjustment
+2/-2mm

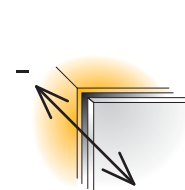





Depth adjustment
+/-2mm



All bulk packaging parts are available upon special request.

For further explanation → see page 1.43-1.44

	External cabinet width (mm)	Item number	Color	
			White	Anthracite grey
Square Side Bar 	270	650.8727 →	150	185*
	300*	650.8730 →	150	185*
	350	650.8735 →	150	185*
	400	650.8740 →	150	185*
	450	650.8745 →	150	185*
	500	650.8750 →	150	185*
	550	650.8755 →	150	185*
	<hr/>			
Drawer Front Marking Jig for Tekform DWD 		650.8025		
<hr/>				
Rear Connectors 	For DW70	650.8901 →	150	185*
	For DW113	650.8911 →	150	
	For DW145	650.8902 →	150	185*
	For DW182	650.8903 →	150	185*
<hr/>				
Front Connectors 	EasyFix	650.8907 →		380*
	Screw-In	650.8905 →		380*
<hr/>				
Decorative Cover 	Tekform by Titus	650.8904 →	350	385*
	Generic	650.8906 →	350	385*



A trial mounting is always recommended. For further information please contact Titus Tekform.

Inner Drawer Front for Tekform Drawer DW70

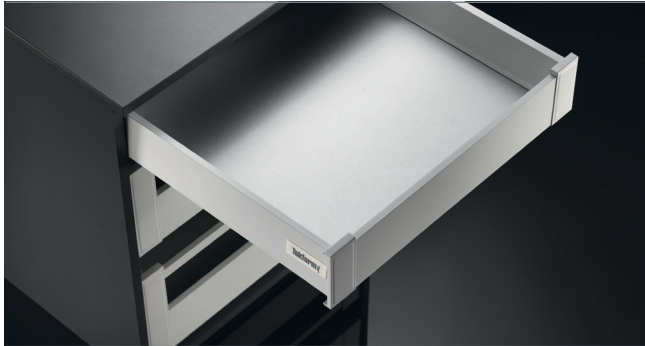
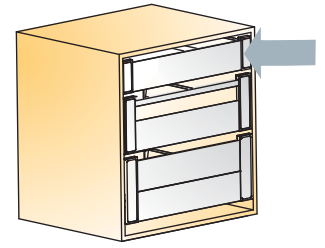

Front Panel



Cutting dimension= ICW-90
ICW > see page 1.55

Made of aluminium

Front Bracket Set DW70
(L+R)



Made of aluminium and plastic

Length (mm)	Item number	Color	
		White	Anthracite grey
600*	650.8565 →	511	515*
1200	650.8569 →	511	515*
Assembly details → see page 1.70			
	650.8912 →	350	385*
Assembly details → see page 1.70			



Front panel support clip
002110.885.300 white

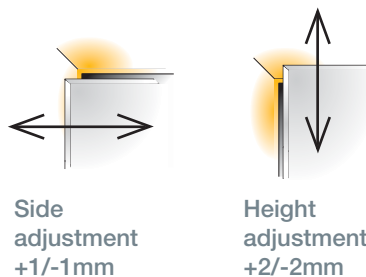
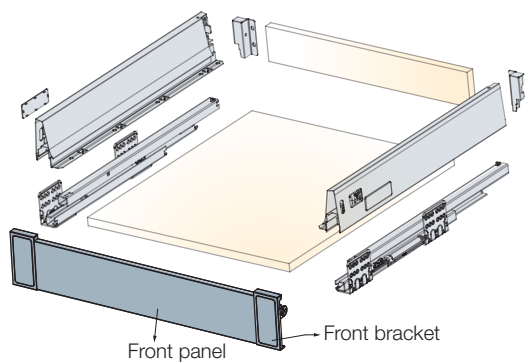

For further explanation → see page 1.43-1.44

Installation dimensions

Minimum space required for the cabinet

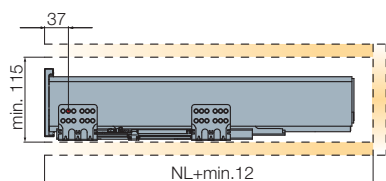

Cutting dimensions details

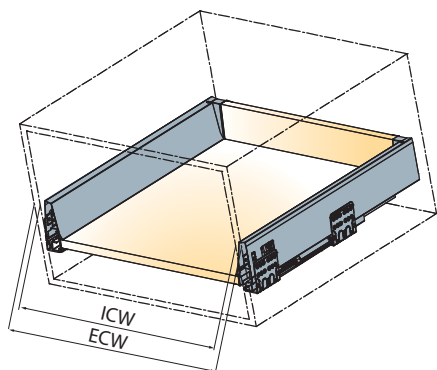

ECW: External cabinet width
 ICW: Internal cabinet width
 NL: Nominal length of drawer

Drawer runner fixing positions

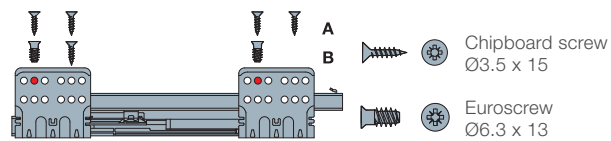

⚠ Use the second hole for runner fixing.

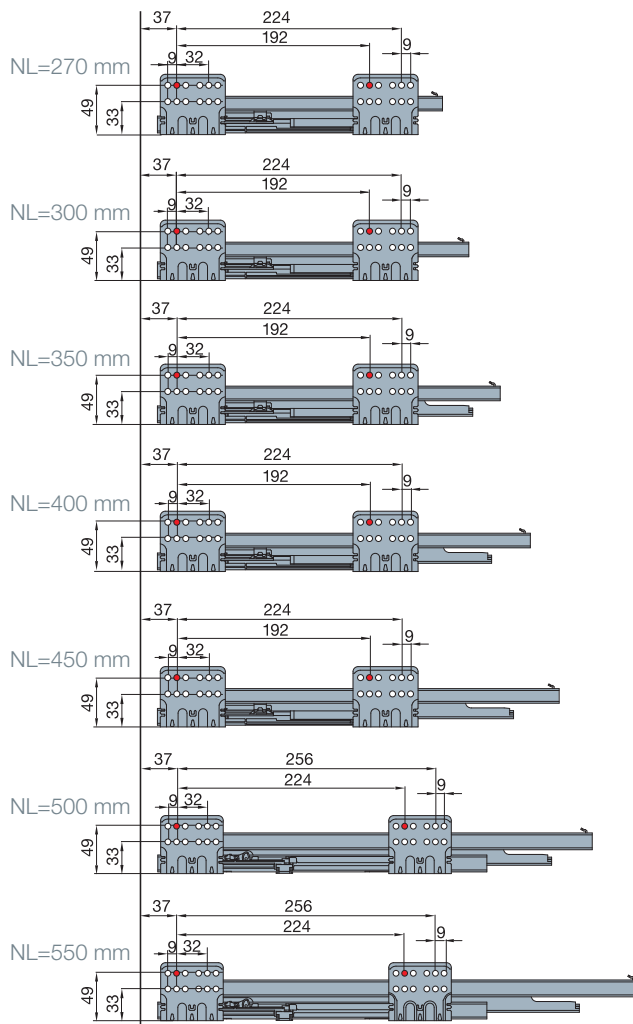

A trial mounting is always recommended. For further information please contact Titus Tekform.

Inner Drawer Front for Tekform Drawer DW145 With Square Bar

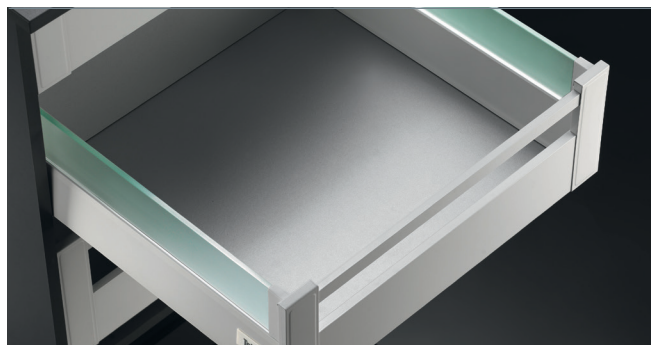
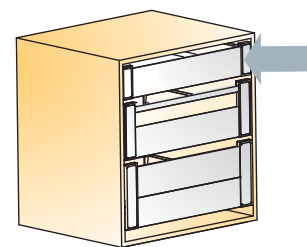

Front Panel

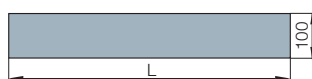

Cutting dimension= ICW-98
ICW → see page 1.57

Made of aluminium

Front Bracket Set (L+R)
DW145



Made of aluminium and plastic

Square Bar



Cutting dimension= ICW-98
ICW → see page 1.57

Made of aluminium

Length (mm)	Item number	Color	
		White	Anthracite grey
600*	650.8565 →	511	515*
1200	650.8569 →	511	515*
Assembly details → see page 1.70			
	650.8914 →	350	385*
Assembly details → see page 1.70			
600*	650.8600 →	511	515*
1200	650.8604 →	511	515*



Front panel support clip
002110.885.300 white

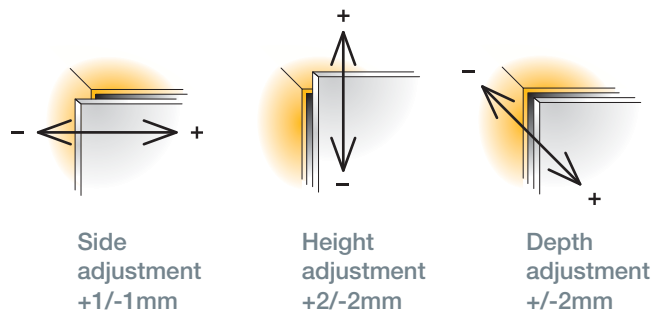
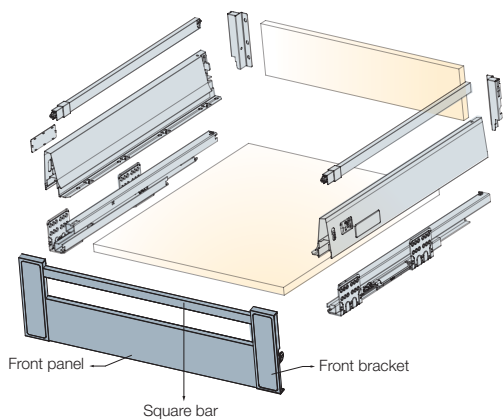

For further explanation → see page 1.43-1.44

Installation dimensions

Minimum space required for the cabinet

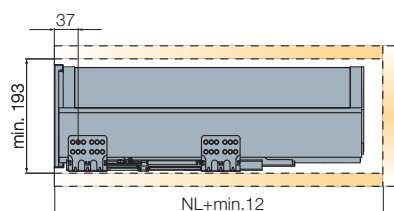

Cutting dimensions details

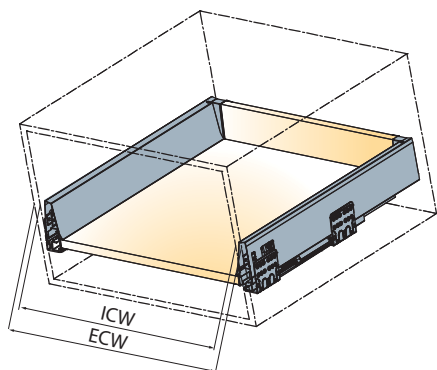

ECW: External cabinet width
ICW: Internal cabinet width
NL: Nominal length of drawer

Drawer runner fixing positions

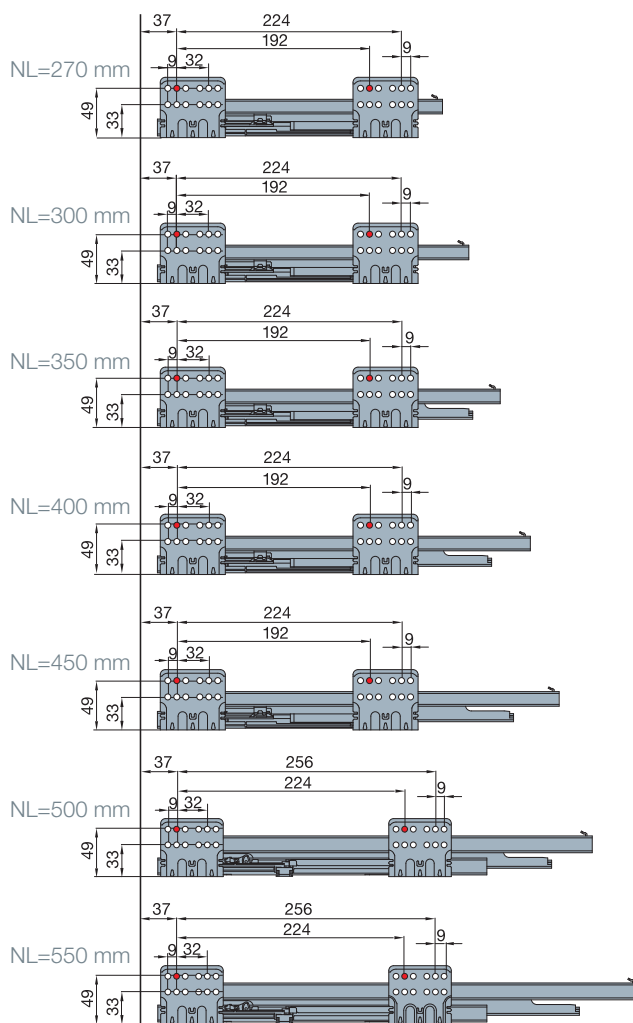
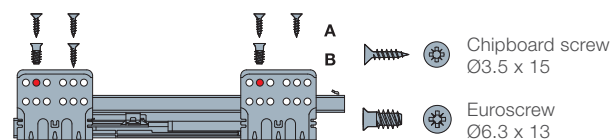

A trial mounting is always recommended. For further information please contact Titus Tekform.

Inner Drawer Front for Tekform Drawer DW182 With Square Bar

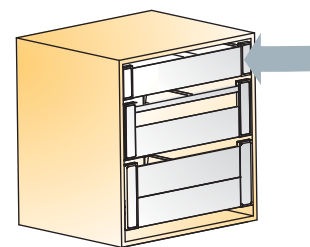

Front Panel

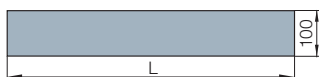

Cutting dimension= ICW-98
ICW → see page 1.57

Made of aluminium

Front Bracket Set (L+R)
DW182



Made of aluminium and plastic

Square Bar

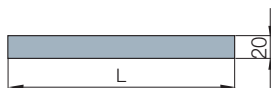

Cutting dimension= ICW-98
ICW → see page 1.57

Made of aluminium

Length (mm)	Item number	Color	
		White	Anthracite grey
600*	650.8565 →	511	515*
1200	650.8569 →	511	515*
Assembly details → see page 1.70			
	650.8916 →	350	385*
Assembly details → see page 1.70			
600*	650.8600 →	511	515*
1200	650.8604 →	511	515*



Front panel support clip
002110.885.300 white

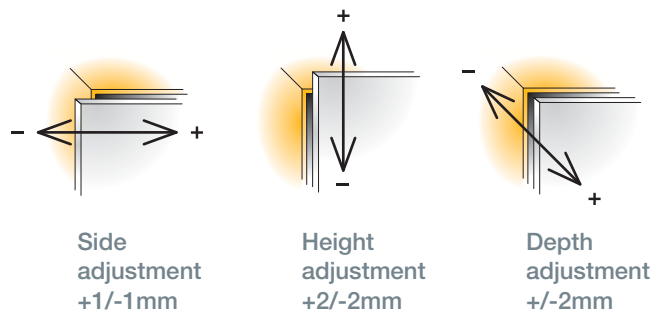
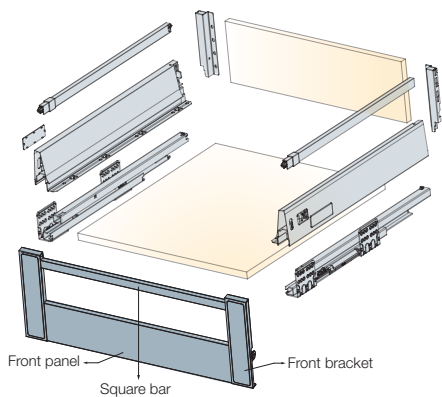

For further explanation → see page 1.43-1.44

Installation dimensions

Minimum space required for the cabinet

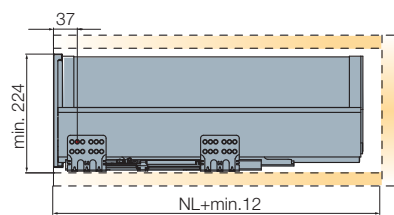

Cutting dimensions details

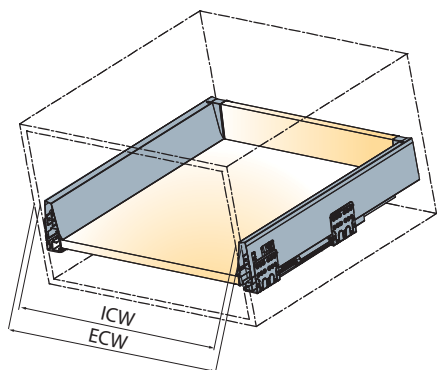

ECW: External cabinet width
ICW: Internal cabinet width
NL: Nominal length of drawer

Drawer runner fixing positions

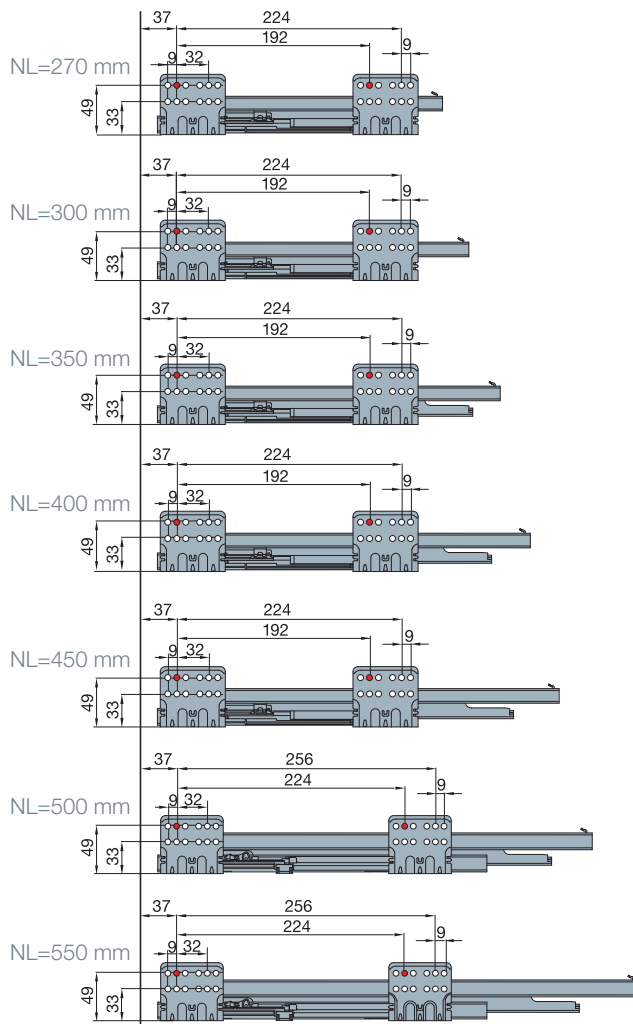
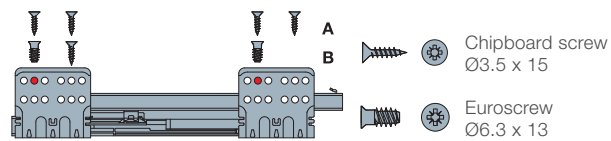

A trial mounting is always recommended. For further information please contact Titus Tekform.

Accessories

Glass Sides 4mm

- 4mm glass sides must be applied with drawer side bars
- Tempered glass for improved user safety
- Depth front adjustment through side bars enabled



For DW145

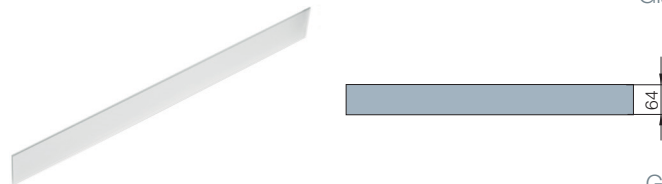

Glass side



Glass clip

Made of tempered glass, glass clip made of plastic

For DW182

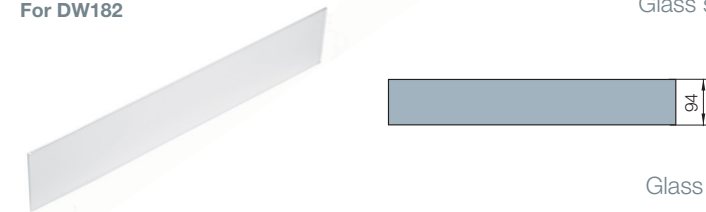

Glass side



Glass clip

Made of tempered glass, glass clip made of plastic

NL	Nominal length (mm)	Item number	Color		
			Frosted glass	White	Anthracite grey

Glass side set

Glass clip set

400	650.8404 →	391		
450	650.8405 →	391		
500	650.8406 →	391		
550	650.8407 →	391		
	650.8484 →		350	385*

Assembly instructions > see page 1.70

Glass side set = 2 pcs
Glass clip set = 2 pcs L + 2 pcs R

Glass side set

Glass clip set

400	650.8440 →	391		
450	650.8445 →	391		
500	650.8450 →	391		
550	650.8455 →	391		
	650.8485 →		350	385*

Assembly instructions > see page 1.70

Glass side set = 2 pcs
Glass clip set = 2 pcs L + 2 pcs R

Accessories

Glass Sides 8mm

- 8mm glass sides don't require side bars
- Tempered glass for improved user safety



For DW145



Glass side

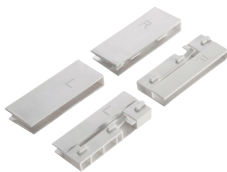

Glass clip

Made of tempered glass, glass clip made of plastic

Glass side set



Glass clip set

NL	Nominal length (mm)	Item number	Color options		
			Frosted glass	White	Anthracite grey
	400	650.8463 →	391		
	450	650.8464 →	391		
	500	650.8465 →	391		
	550	650.8466 →	391		
		650.8488 →		350	385*

Assembly instructions > see page 1.71

Glass side set = 2 pcs
Glass clip set = 2 pcs L + 2 pcs R

For DW182



Glass side



Glass clip

Made of tempered glass, glass clip made of plastic

Glass side set



Glass clip set

	400	650.8470 →	391		
	450	650.8471 →	391		
	500	650.8472 →	391		
	550	650.8473 →	391		
		650.8489 →		350	385*

Assembly instructions > see page 1.71

Glass side set = 2 pcs
Glass clip set = 2 pcs L + 2 pcs R

Accessories

Drawer Storage System

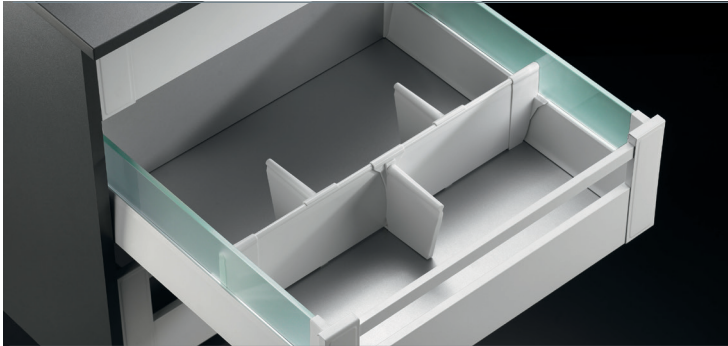

**Drawer Storage System
for DW145**

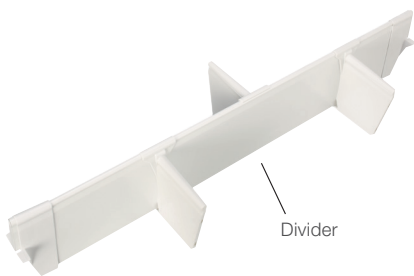

Divider



Divider fitting



Riser

	NL	Item number		
	Nominal length (mm)		White	Anthracite grey
Divider	600	650.8706 →	511	515*
	1200	650.8712 →	511	515*
Riser		650.8703 →	511	515*
Divider fitting		650.8704 →	511	515*

Made of aluminium and plastic

Assembly Instructions



Screws not included

Assembly Sequence

Connect the drawer sides to the bottom panel (1) and fix it with screws (2)

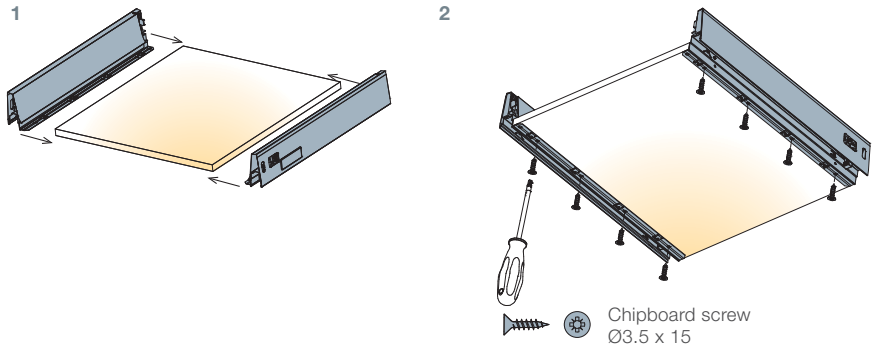

Insert the rear connector vertically (3) and push it downwards into recess in the drawer side (4)

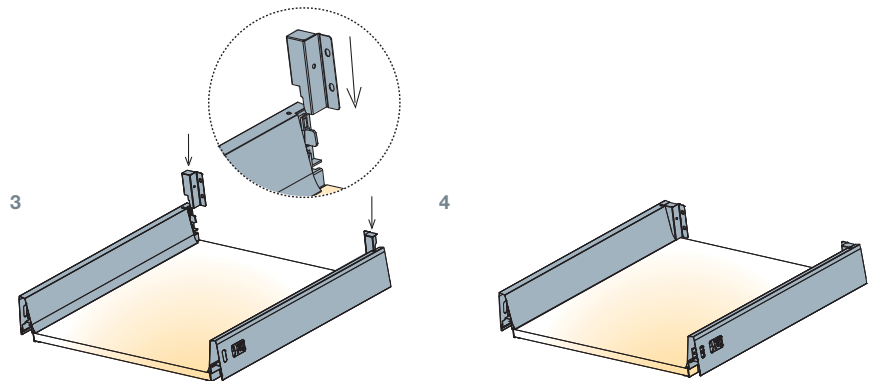

Insert the back panel (5) and fix it with screws (6)

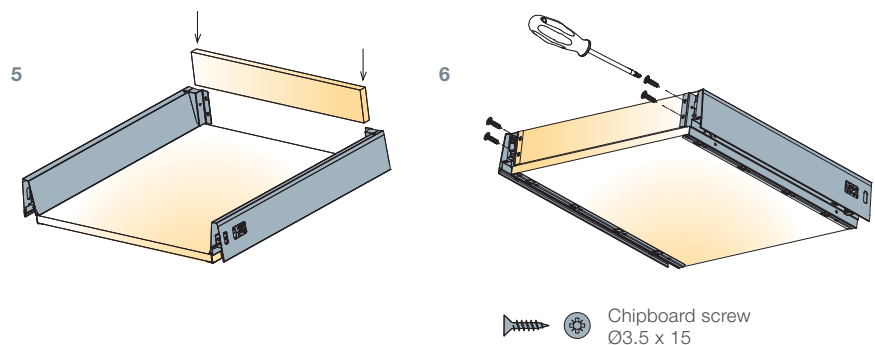

Assembly Instructions



Screws not included

Insertion of Front Connectors

EasyFix

Insert the front connectors into holes on the front panel

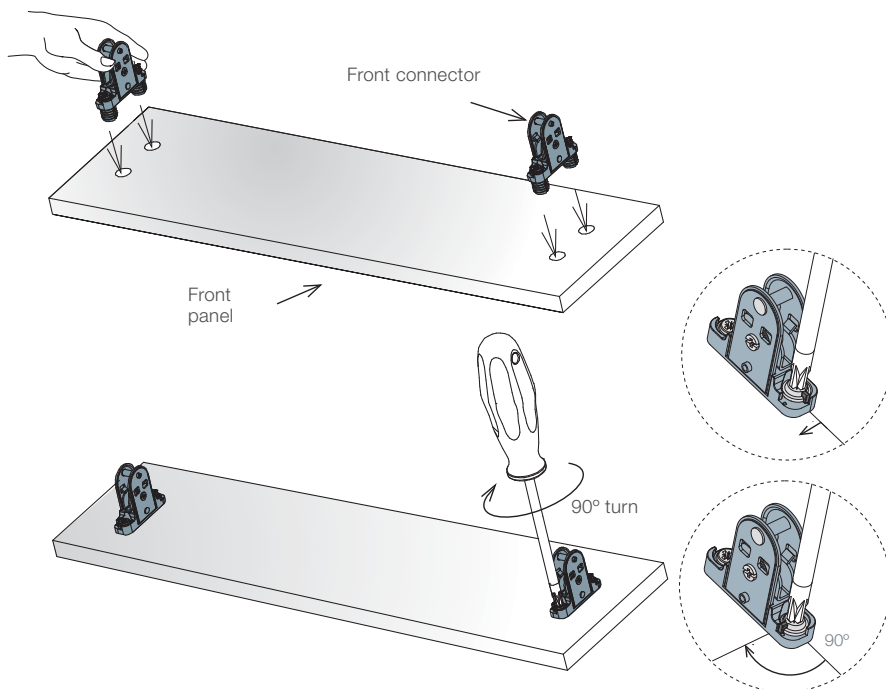

Turn the screws for 90° into locked position

Screw-in fixing

Use Ø3.5 x 15mm screws for fixing

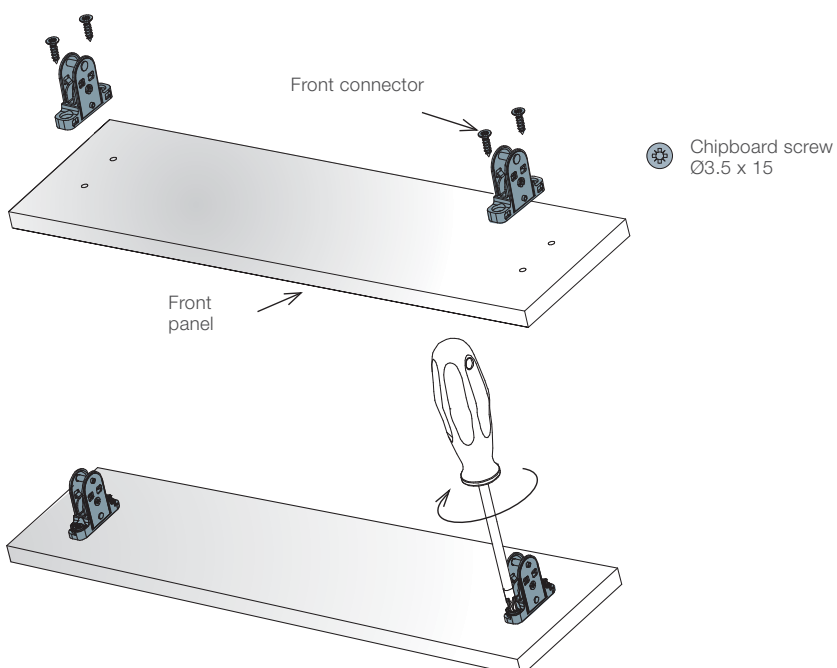

Assembly Instructions

Front Panel Mounting / Removal

Mounting

Attach the front panel to the drawer and press to click

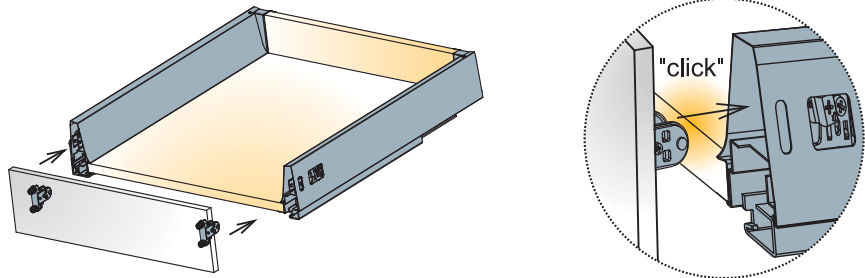

Removal

Rotate to disengage

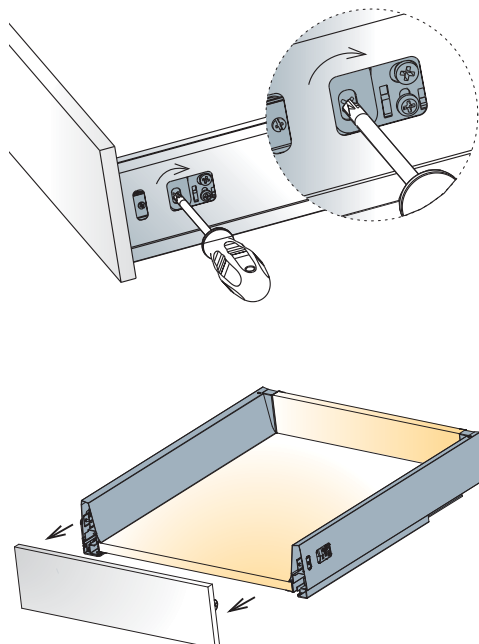

Assembly Instructions

Drawer Insertion & Removal

Insertion

Put the drawer horizontally on the runners and push towards the cabinet until you hear the drawer is locked

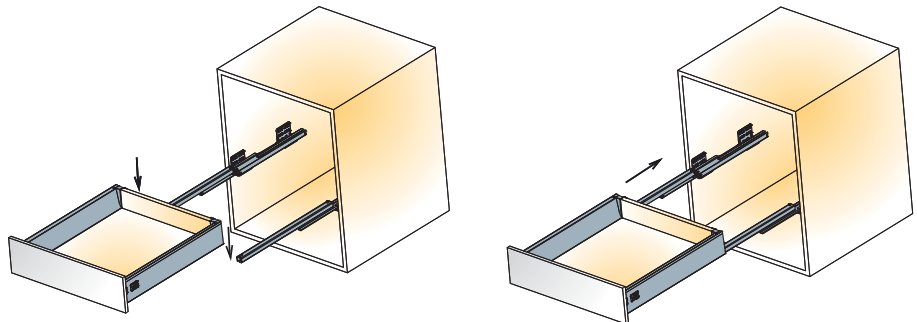

Push to fully close

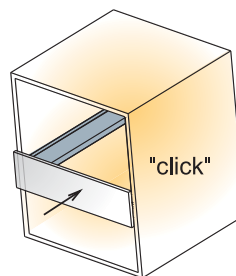

Removal

Press the button under a drawer keep pressed to pull the drawer out

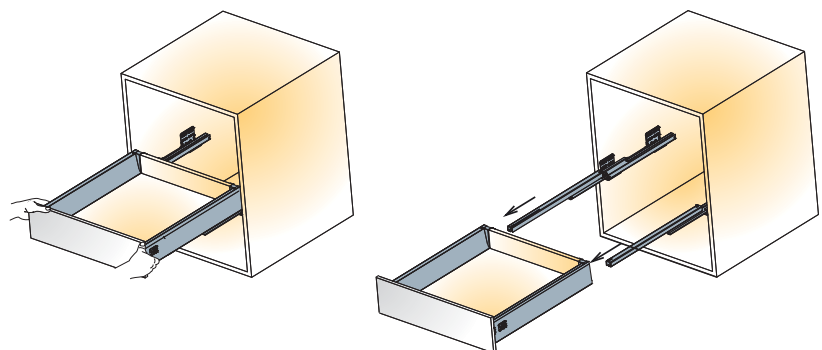

Assembly Instructions



Adjustment needs to be done on both sides of the drawer.

Side / Height Adjustment

Side Adjustment

The side adjustment enables drawer front alignment with the side of the cabinet and perfect lifetime opening and closing of the drawer.

To align the drawer front with the cabinet side, rotate the adjustment screw.

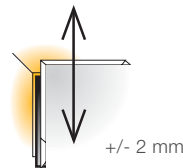
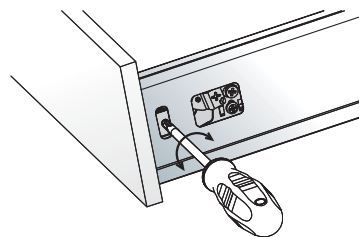
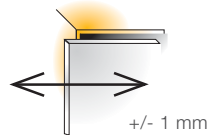

Height Adjustment

Height adjustment enables perfect vertical positioning of the drawer.

To align the drawer front, release the locking screw (1), rotate the eccentric dowel (2) and tighten the locking screw back (3).

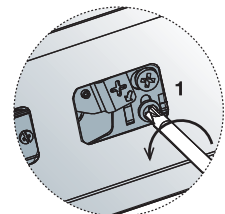
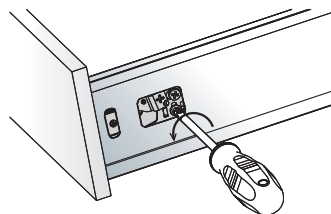

Release

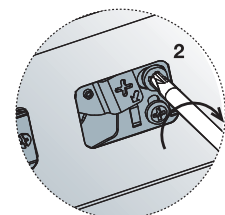
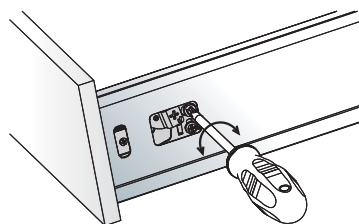

Adjust

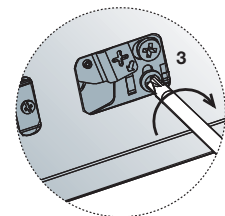
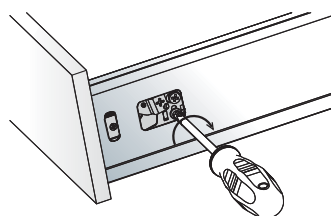

Tighten

Accessories Mounting

Mounting of Connecting Bars and Glass Sides 4mm

Connecting Bars
(for DW145 and DW182)

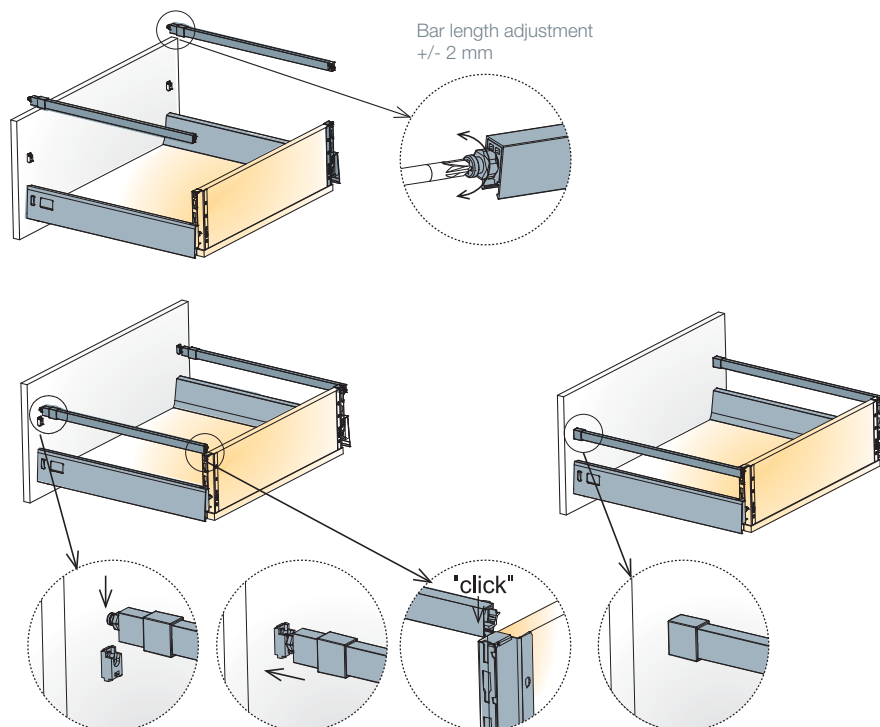

Glass Sides 4mm

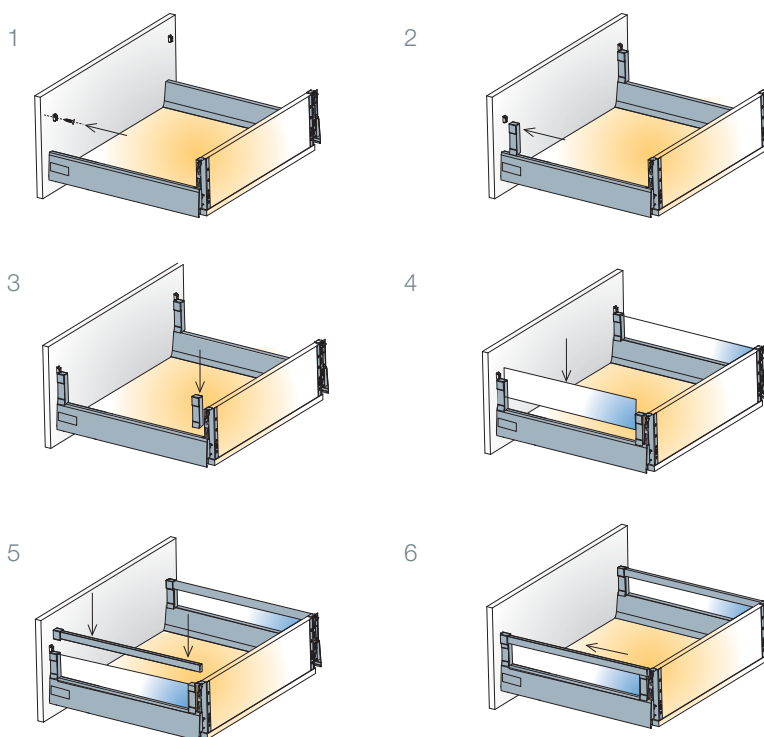



Screws not included

Mounting of Glass Sides 8mm

Glass Sides 8mm

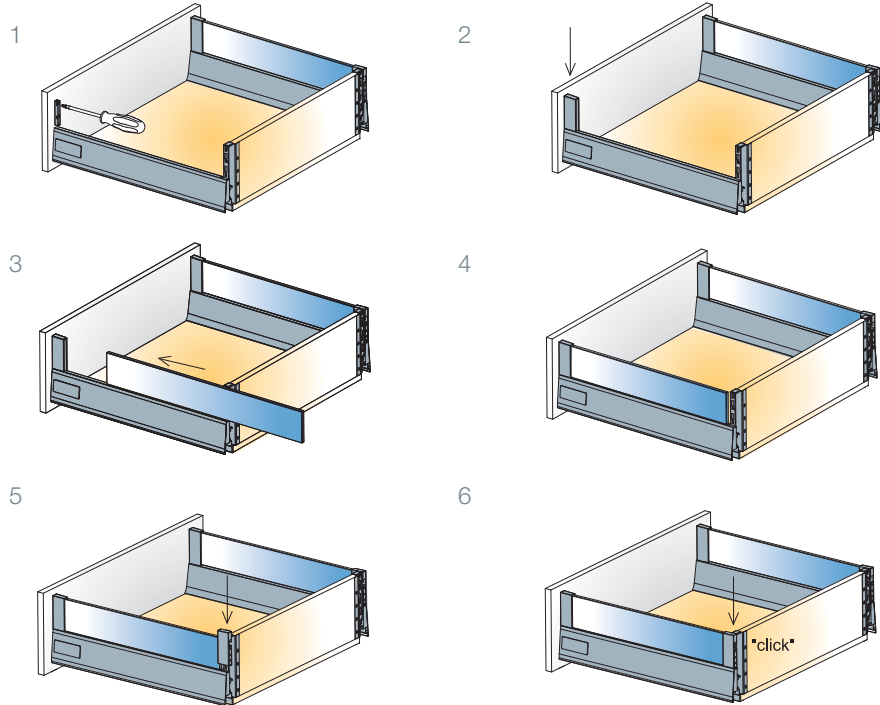

Drilling dimension for Glass Sides 8mm

Back panel mounting dimensions

Tekform Drawer DW145

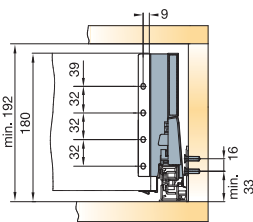

Tekform Drawer DW182

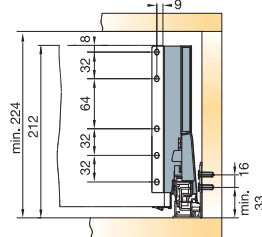

Front panel drilling dimensions

'EasyFix' front connector

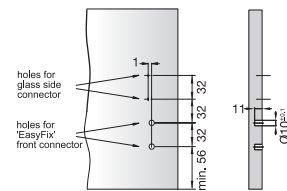
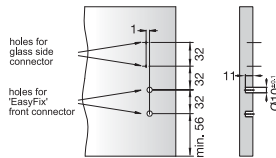

Installation dimensions for front panel

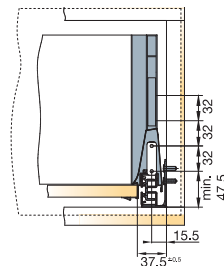
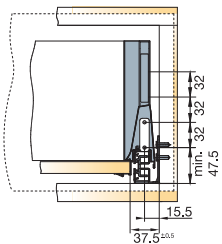

Accessories Mounting

Assembly of Inner Drawer Front

DW70

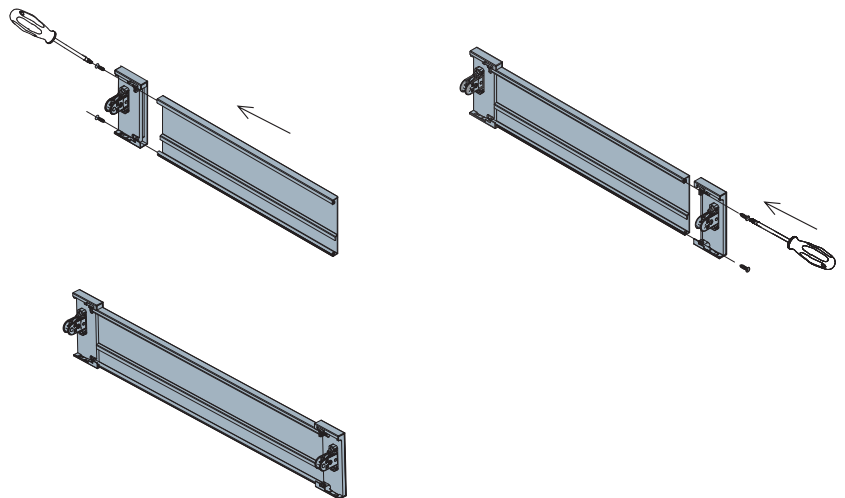

DW145 and DW182 with
Square Connecting Bar

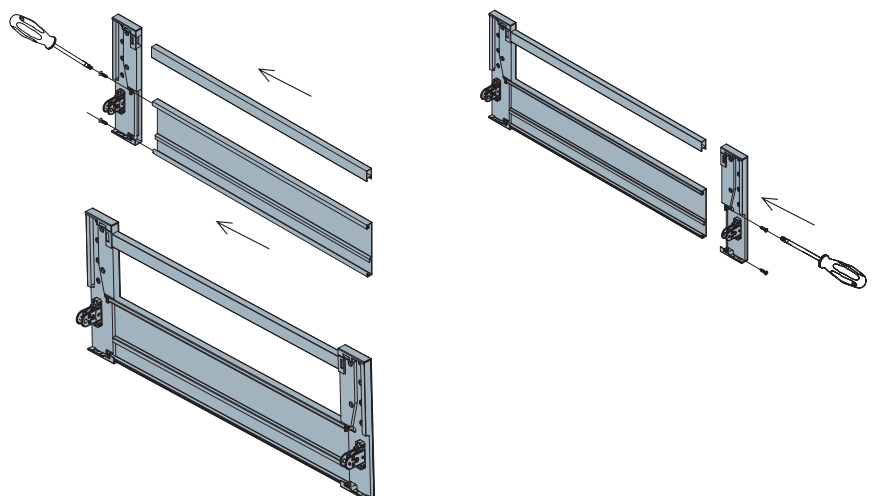

Tekform Single Wall Drawer

Product Guide

Tekform Single Wall Drawer

Page

Tekform Drawer SW85



1.76

Tekform Drawer SW117



1.78

Tekform Drawer SW150



1.80

Tekform Drawer SW200



1.82

Accessories

Front Clips

1.84

Round Railings

1.85

Tekform Single Wall Drawer

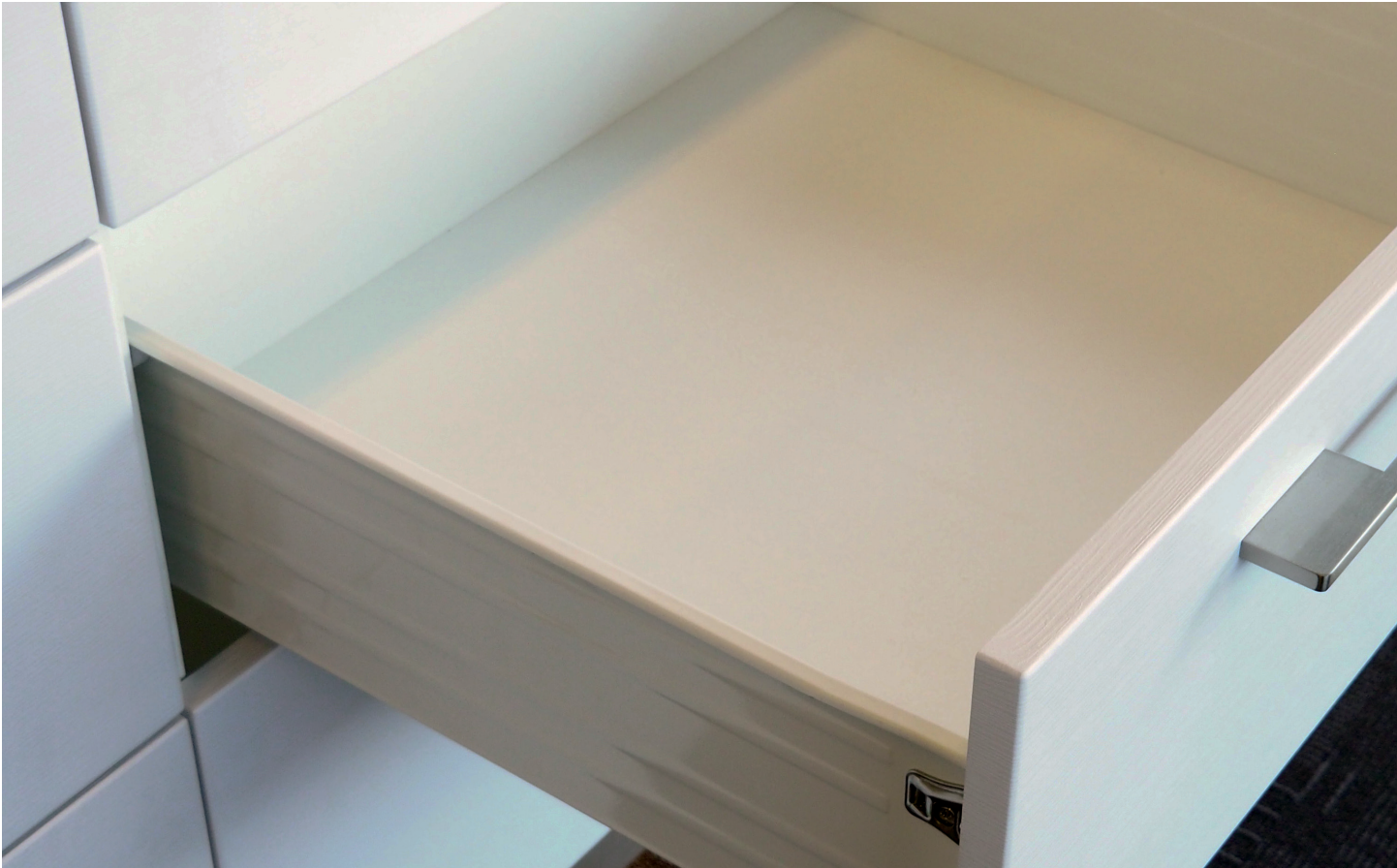

Lifetime warranty

- 50,000 cycle tested lifetime warranty

Quality certified

- By European specialised institutions
- Level 5 Heavy Domestic
- CATAS
- FIRA

Easy front fixing

- Front clips available for all drawer fixing methods
- Spring loaded action for easy location of the drawer front

User friendly mounting

- Intuitive installation instructions
- Easy assembly and disassembly of the drawer
- Assembly equipment available

Precise drawer alignment

- Huge vertical cam adjustment
- Provides a total +/- 4mm adjustment
- Side adjustment +/- 1.5mm



Tekform Drawer SW85



Tekform Drawer SW117



Tekform Drawer SW150



Tekform Drawer SW200

Versatile and Reliable

The Single Wall Tekform Drawer is the perfect solution to solve kitchen, wardrobe and bathroom vanity drawer applications. Both strong and affordable, the drawer's fluid sliding movement is due to the use of a roller slide system, whilst the epoxy coating makes it silent during operation. The product is available in a large range of heights and depths. The immediate vertical adjustment makes the drawer very versatile and easy to use; it is also ideal both for automatic and manual assembly.

Tekform Drawer SW85

- Large range of dimensions from 250mm to 550mm depth
- Screw-on, dowel fixing machine insertion ready or C15 assembly options
- Simple bottom mounting for ease of assembly
- Unilateral restraint-guide compensates for tolerances

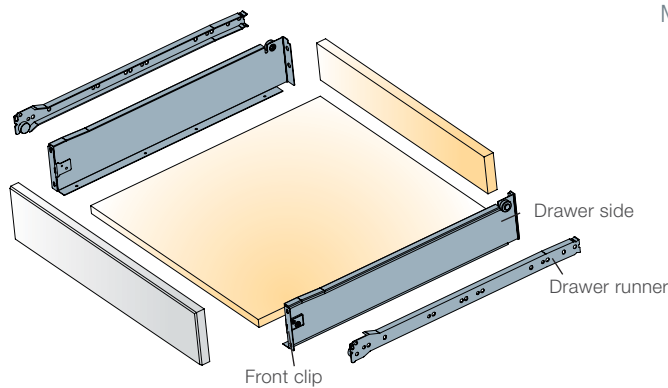
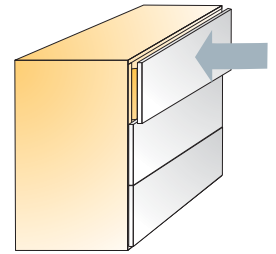

Cutting dimensions details

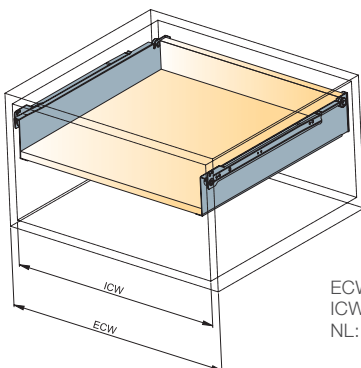

ECW: External cabinet width
 ICW: Internal cabinet width
 NL: Nominal length of drawer

Bottom panel

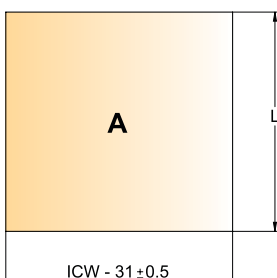

Back panel

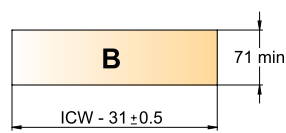

If wooden back panel > L=NL-2

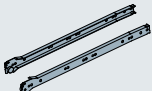
NL	Item number	White
Nominal length (mm)		
Machine insertion	500 603.8C68.050 →	150
C15 assembly	250 603.8C62.025 →	150
	270 603.8C62.027 →	150
	350 603.8C62.035 →	150
	400 603.8C62.040 →	150
	450 603.8C62.045 →	150
	500 603.8C62.050 →	150
	550 603.8C62.055 →	150
One set consists of		
Drawer Sides		2 pcs
Drawer Runner		2 pcs
Assembly instructions → see page 1.85		



Push latch → page 2.68



Titusoft MD → page 2.92



Front clips → page 1.84

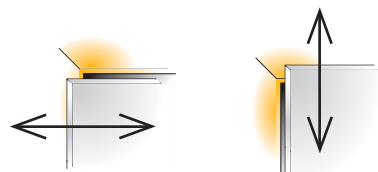

Side adjustment
+/- 1.5mm

Height adjustment
+/- 2.5mm

- Drawer runner type
 - Load capacity
 - Minimum height space required
 - Wooden back panel thickness
- Single extension roller
25kg
106.5mm
12-18mm

Installation dimensions and drilling patterns

Drawer runner fixing positions

Front panel drilling pattern

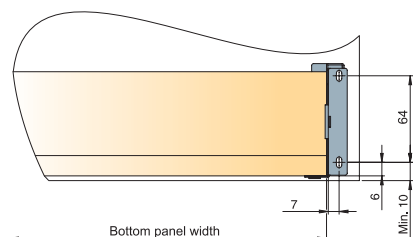

Back panel drilling pattern

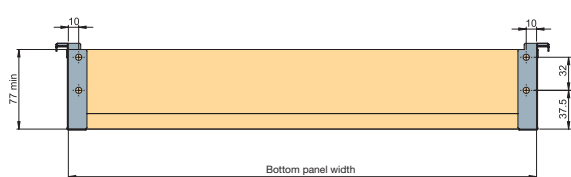

Installation and back panel dimensions

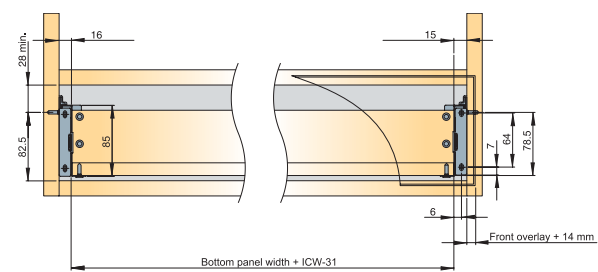

Drawer runner mounting

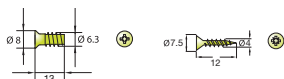
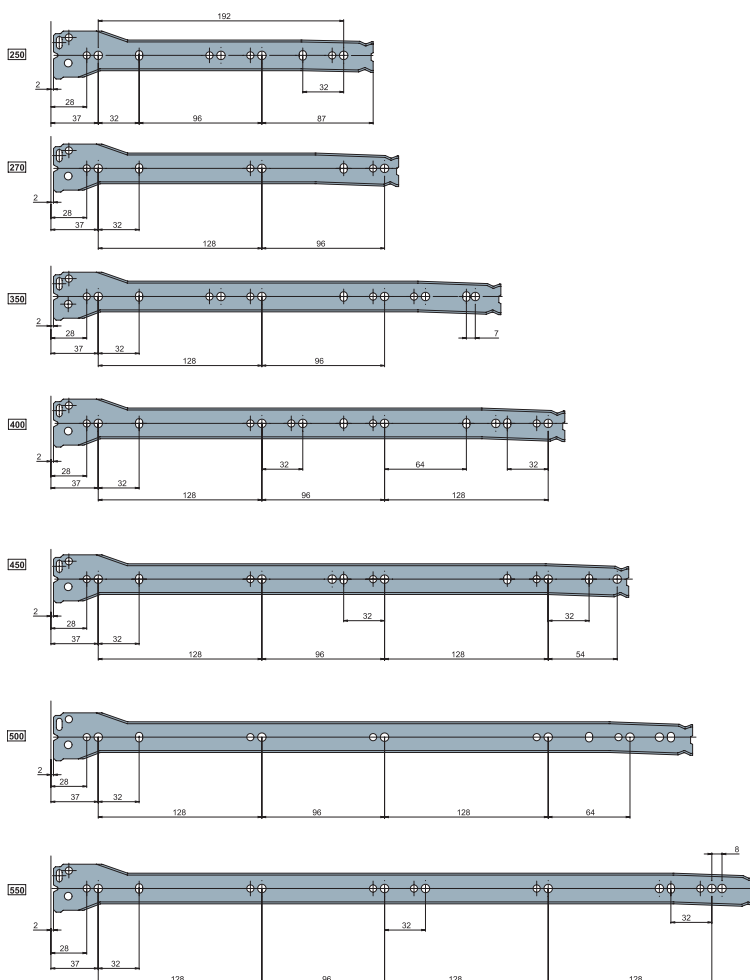
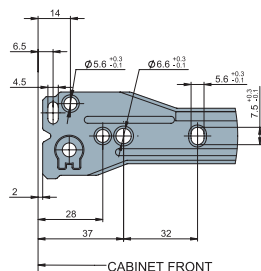

Fixing screws for front brackets and drawer runner

Euro Screws
611.8E23.363.813

Chipboard screws
611.8K16.240.016

Tekform Drawer SW117

- Large range of dimensions from 250mm to 550mm depth
- Screw-on, dowel fixing machine insertion ready or C15 assembly options
- Simple bottom mounting for ease of assembly
- Unilateral restraint-guide compensates for tolerances

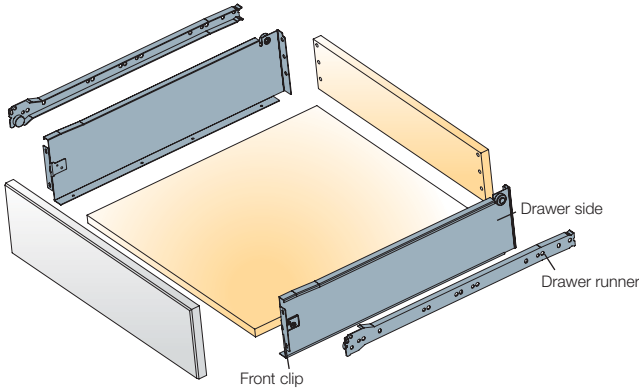
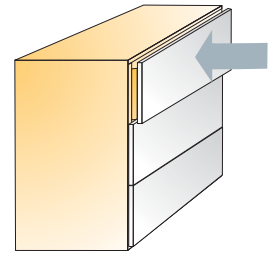

Cutting dimensions details

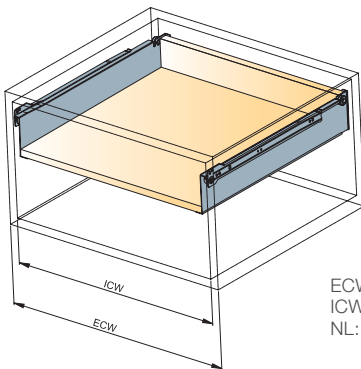

ECW: External cabinet width
 ICW: Internal cabinet width
 NL: Nominal length of drawer

Bottom panel

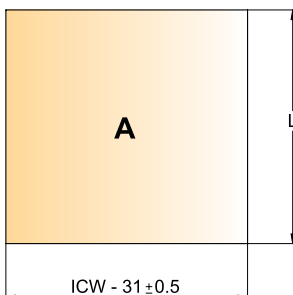

Back panel

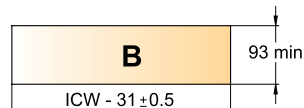

If wooden back panel > L=NL-2

NL	Item number	White
Nominal length (mm)		
C15 assembly		
250	603.8C72.025 →	150
270	603.8C72.027 →	150
350	603.8C72.035 →	150
400	603.8C72.040 →	150
450	603.8C72.045 →	150
500	603.8C72.050 →	150
550	603.8C72.055 →	150
One set consists of		
Drawer Sides		2 pcs
Drawer Runner		2 pcs
Assembly instructions → see page 1.85		



Push latch → page 2.68



Titusoft MD → page 2.92



Front clips → page 1.84

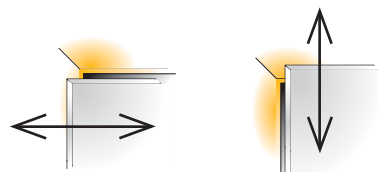

Side adjustment
+/- 1.5mm

Height adjustment
+/- 2.5mm

- Drawer runner type
- Load capacity
- Minimum height space required
- Wooden back panel thickness

Roller sides
25kg
138.5mm
12-18mm

Installation dimensions and drilling patterns

Drawer runner fixing positions

Front panel drilling pattern

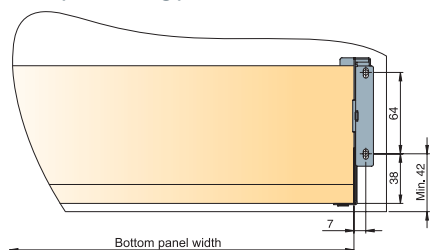

Back panel drilling pattern

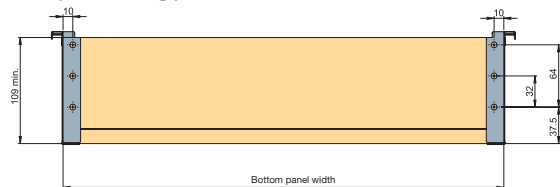

Installation and back panel dimensions

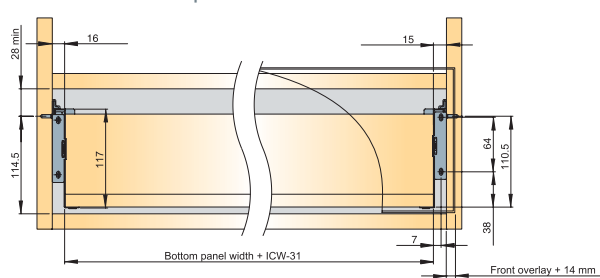

Drawer runner mounting

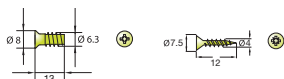
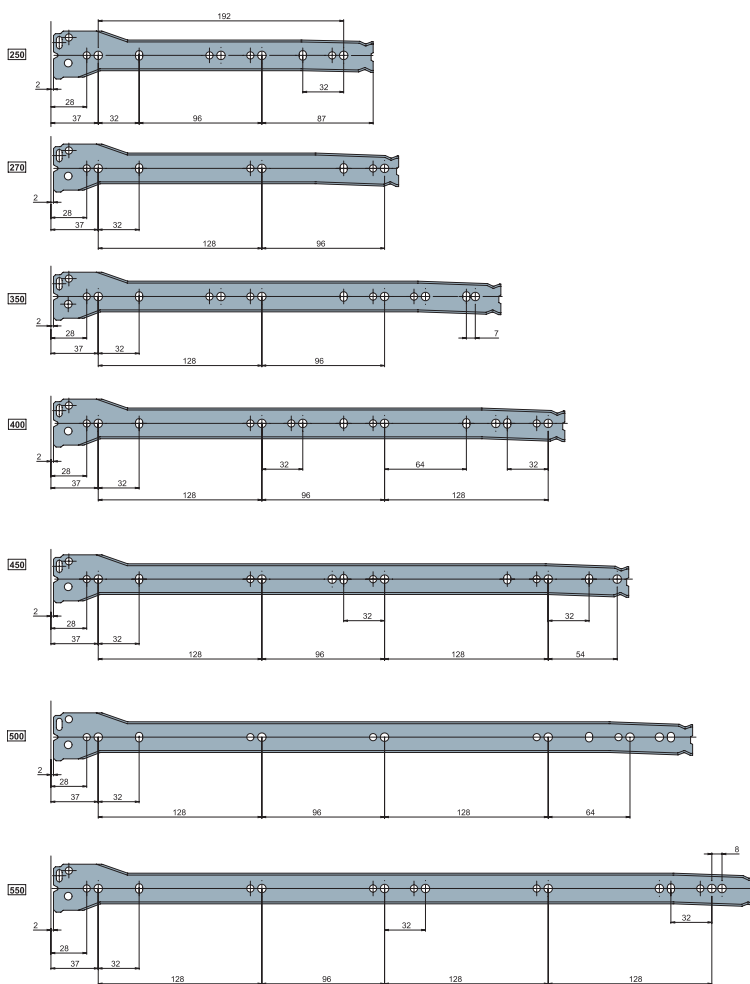
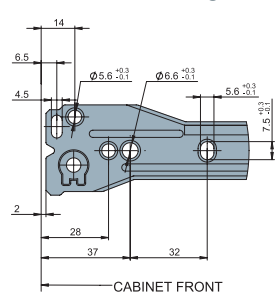

Fixing screws for front brackets and drawer runner

Euro Screws
611.8E23.363.813

Chipboard screws
611.8K16.240.016

Tekform Drawer SW150

- Large range of dimensions from 250mm to 550mm depth
- Screw-on, dowel fixing machine insertion ready or C15 assembly options
- Simple bottom mounting for ease of assembly
- Unilateral restraint-guide compensates for tolerances

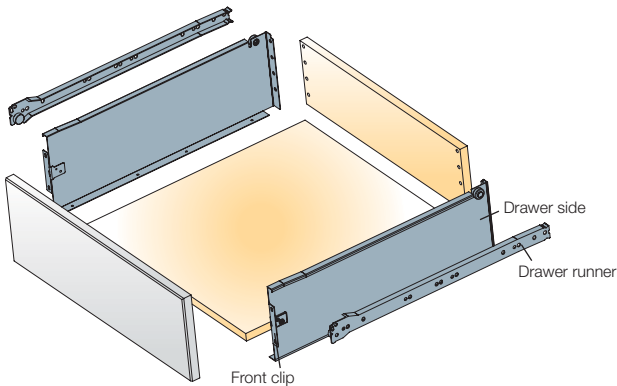
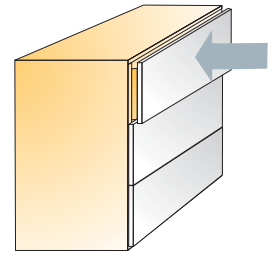

Cutting dimensions details

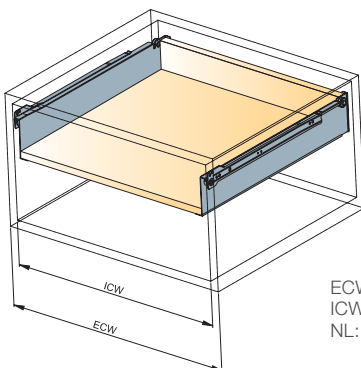

ECW: External cabinet width
 ICW: Internal cabinet width
 NL: Nominal length of drawer

Bottom panel

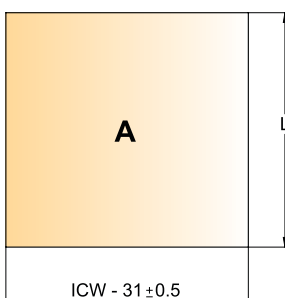

Back panel

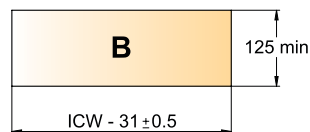

If wooden back panel > L=NL-2

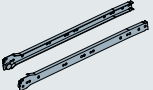
NL	Item number	White
Nominal length (mm)		
C15 assembly		
250	603.8C82.025 →	150
270	603.8C82.027 →	150
350	603.8C82.035 →	150
400	603.8C82.040 →	150
450	603.8C82.045 →	150
500	603.8C82.050 →	150
550	603.8C82.055 →	150
One set consists of		
Drawer Sides		2 pcs
Drawer Runner		2 pcs
Assembly instructions → see page 1.85		



Push latch → page 2.68



Titusoft MD → page 2.92



Front clips → page 1.84

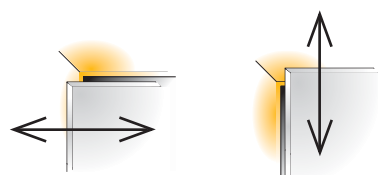

Side adjustment
+/- 1.5mm

Height adjustment
+/- 2.5mm

- Drawer runner type
- Load capacity
- Minimum height space required
- Wooden back panel thickness

Roller sides
25kg
170.5mm
12-18mm

Installation dimensions and drilling patterns

Drawer runner fixing positions

Front panel drilling pattern

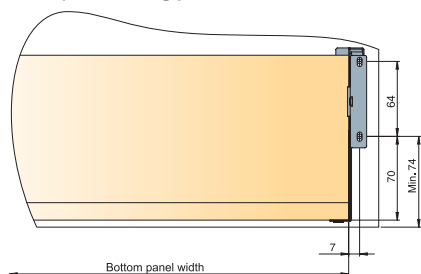

Back panel drilling pattern

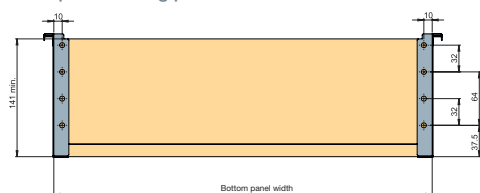

Installation and back panel dimensions

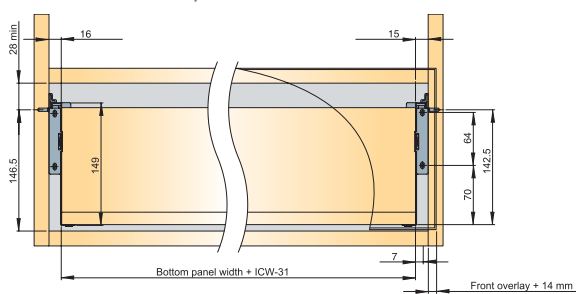

Drawer runner mounting

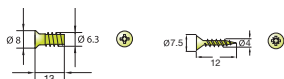
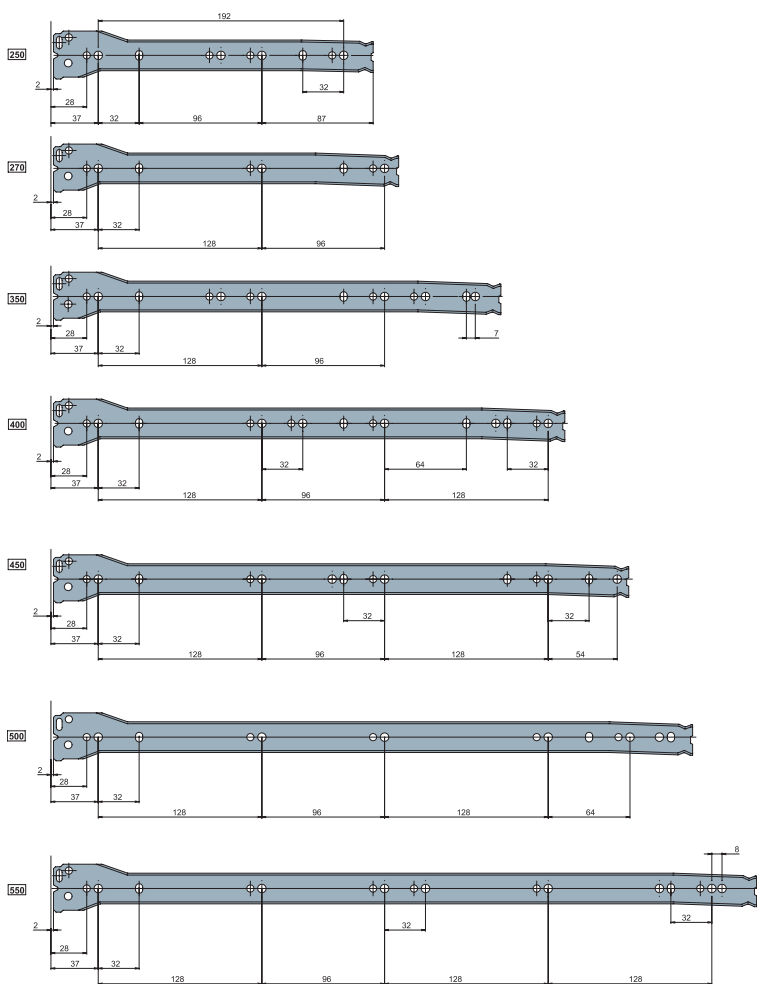
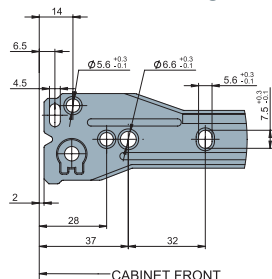

Fixing screws for front brackets and drawer runner

Euro Screws
611.8E23.363.813

Chipboard screws
611.8K16.240.016

Tekform Drawer SW200

- Large range of dimensions from 250mm to 550mm depth
- Screw-on, dowel fixing machine insertion ready or C15 assembly options
- Simple bottom mounting for ease of assembly
- Unilateral restraint-guide compensates for tolerances

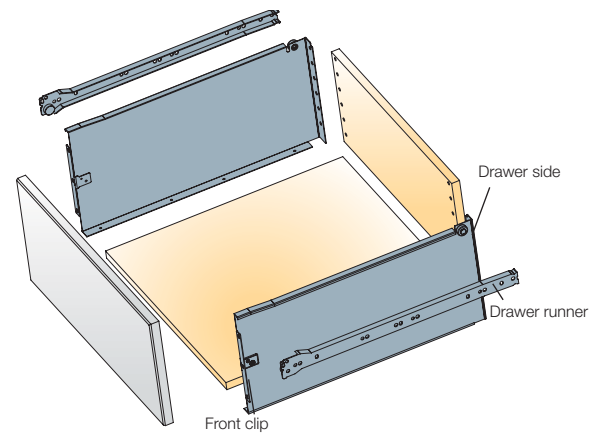
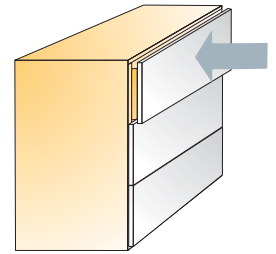

Cutting dimensions details

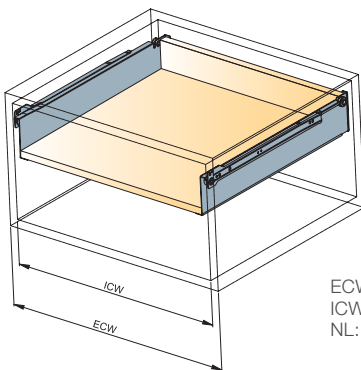

ECW: External cabinet width
 ICW: Internal cabinet width
 NL: Nominal length of drawer

Bottom panel

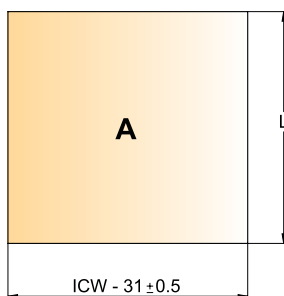

Back panel

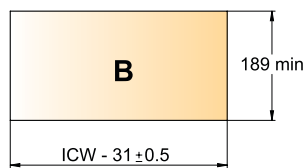

If wooden back panel > L = NL - 2

NL	Nominal length (mm)	Item number	White
C15 assembly			
250	250	603.8C92.025 →	150
270	270	603.8C92.027 →	150
350	350	603.8C92.035 →	150
400	400	603.8C92.040 →	150
450	450	603.8C92.045 →	150
500	500	603.8C92.050 →	150
550	550	603.8C92.055 →	150
One set consists of			
Drawer Sides			2 pcs
Drawer Runner			2 pcs
Assembly instructions → see page 1.85			



Push latch → page 2.68



Titusoft MD → page 2.92



Front clips → page 1.84

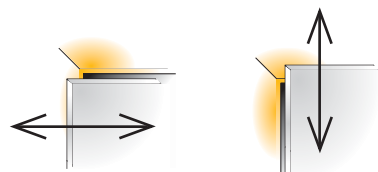

Side adjustment
+/- 1.5mm

Height adjustment
+/- 2.5mm

- Drawer runner type
- Load capacity
- Minimum height space required
- Wooden back panel thickness

Roller sides
25kg
233.5mm
12-18mm

Installation dimensions and drilling patterns

Drawer runner fixing positions

Front panel drilling pattern

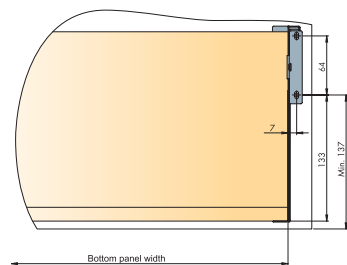

Back panel drilling pattern

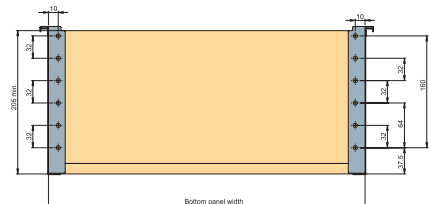

Installation and back panel dimensions

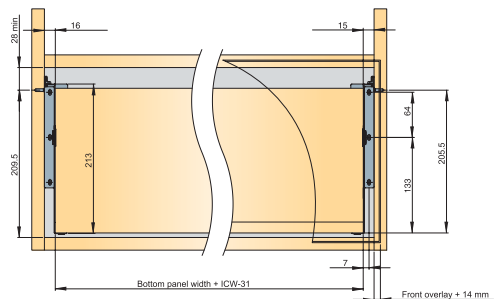

Drawer runner mounting

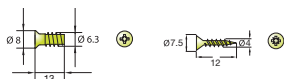
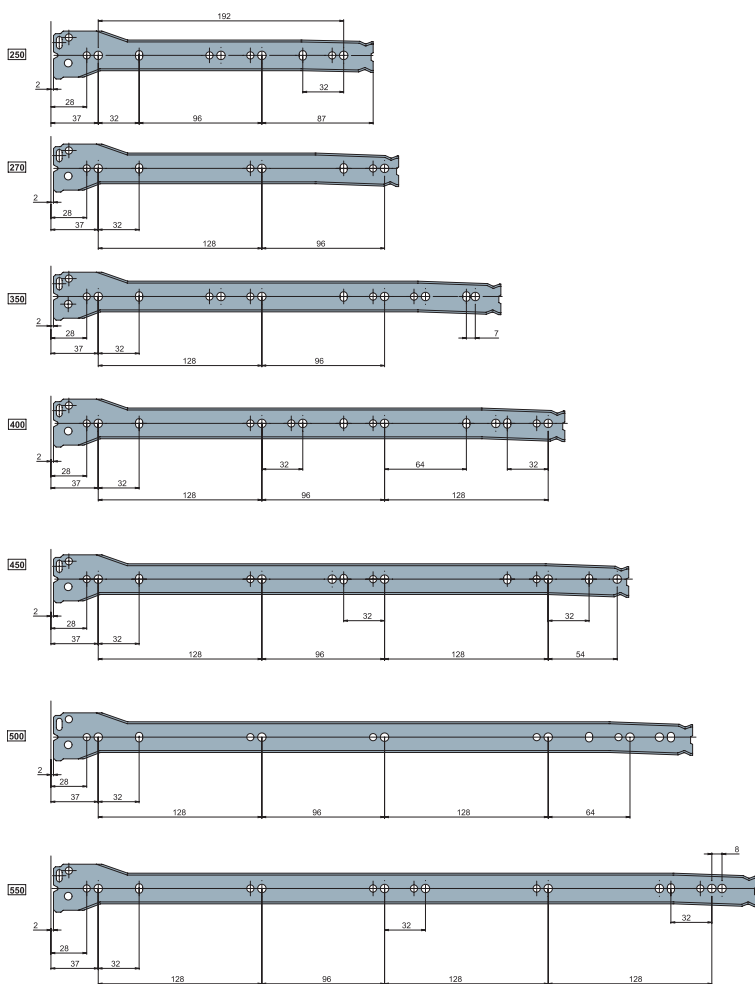
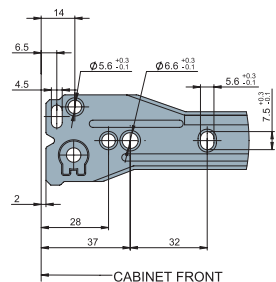

Fixing screws for front brackets and drawer runner

Euro Screws
611.8E23.363.813

Chipboard screws
611.8K16.240.016

Accessories

- Front clips must be ordered separately
- Choose clip based on your preferred mounting method

		Side	Mounting	Item number	
<p>Front Clips</p>  <p>Screw-on</p>  <p>Machine insertion 10mm</p>  <p>Expanding dowel 10mm</p>	Front Clips	Right	Screw-on	603.8C46.005	
		Left	Screw-on	603.8C46.006	
		Right	Machine insertion	603.8C46.010	
		Left	Machine insertion	603.8C46.012	
		Right	Expanding dowel	603.8C46.015	
		Left	Expanding dowel	603.8C46.016	

Accessories

- Improved storage in high drawers
- Easy one-step fixing and screw-on front attachment
- Lasting quality



Round Railings



EasyFix Railing

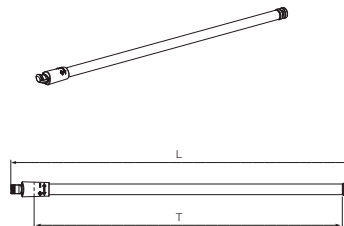

Screw-on Railing

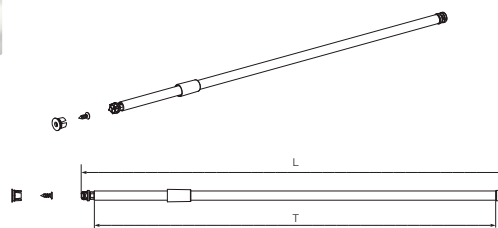

Back Bracket (wood)

Length (mm)	Item number	White
250	603.8C98 →	025.K
270	603.8C98 →	027.K
350	603.8C98 →	035.K
400	603.8C98 →	040.K
450	603.8C98 →	045.K
500	603.8C98 →	050.K
550	603.8C98 →	055.K
250	603.8C98 →	125.K
270	603.8C98 →	127.K
350	603.8C98 →	135.K
400	603.8C98 →	140.K
450	603.8C98 →	145.K
500	603.8C98 →	150.K
550	603.8C98 →	155.K
	603.8C98 →	200

Assembly Instructions

Round Railing for
Wooden Back Panel
Assembly Sequence

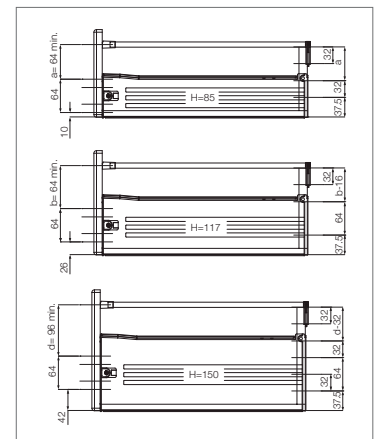
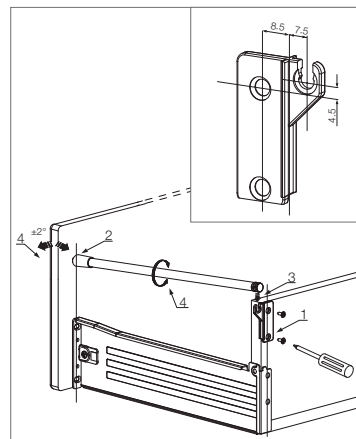

Drawer Runners

Ball Bearing Drawer Runners

- Full extension
- Ball bearing

	Length (mm)	Weight capacity (kg)	Closing	Mounting	Item number	Zinc plated
Ball Bearing Drawer Runners, Full Extension  Made of steel	350	35	Standard	Side	603.8B20.027 →	342
Ball Bearing Drawer Runners, Full Extension with Soft Close  Made of steel	350	35	Soft Close	Side	603.8B20.035 →	450
	400	35	Soft Close	Side	603.8B20.040 →	450
	450	35	Soft Close	Side	603.8B20.045 →	450
	500	35	Soft Close	Side	603.8B20.050 →	450
	550	35	Soft Close	Side	603.8B20.055 →	450
	600	35	Soft Close	Side	603.8B20.060 →	450
	· Integrated soft close					

Drawer Runners

Ball Bearing Drawer Runners

- Full extension
- Ball bearing

	Length (mm)	Weight capacity (kg)	Closing	Mounting	Item number	Black	Zinc plated	
 <p>Ball Bearing Drawer Runners, Full Extension</p>	250	45	Standard	Side	603.8B20.025 →	454		
	300	45	Standard	Side	603.8B21.030 →	454		
	350	45	Standard	Side	603.8B21.035 →	454		
	400	45	Standard	Side	603.8B21.040 →	454		
	450	45	Standard	Side	603.8B21.045 →	454		
	500	45	Standard	Side	603.8B21.050 →	454		
	550	45	Standard	Side	603.8B21.055 →	454		
	600	45	Standard	Side	603.8B21.060 →	454		
	250	45	Standard	Side	603.8B20.025 →		450	
	300	45	Standard	Side	603.8B21.030 →		450	
	350	45	Standard	Side	603.8B21.035 →		450	
	400	45	Standard	Side	603.8B21.040 →		450	
	450	45	Standard	Side	603.8B21.045 →		450	
	500	45	Standard	Side	603.8B21.050 →		450	
	550	45	Standard	Side	603.8B21.055 →		450	
	600	45	Standard	Side	603.8B21.060 →		450	
	650	45	Standard	Side	603.8B21.065 →		450	
	700	45	Standard	Side	603.8B21.070 →		450	
	Made of steel							

Tekform Bottom Mounted Roller Runners

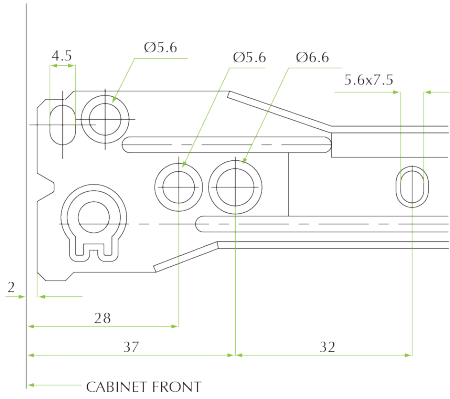
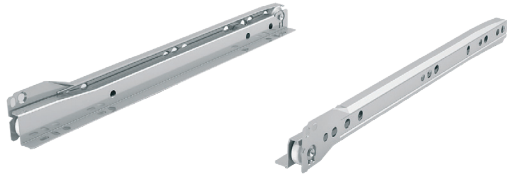
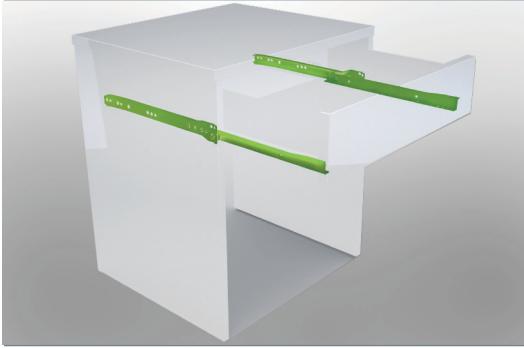

Length (mm)	Weight capacity (kg)	Item number	White
250	25	603.8C05.025 →	001
300	25	603.8C05.030 →	001
350	25	603.8C05.035 →	001
400	25	603.8C05.040 →	001
450	25	603.8C05.045 →	001
500	25	603.8C05.050 →	001
550	25	603.8C05.055 →	001
600	25	603.8C05.060 →	001

- 25kg dynamic standard capacity
- Easy assembly
- Add-on SlowMotion damping available
- Standard closing

Drawer mounting and dimensions

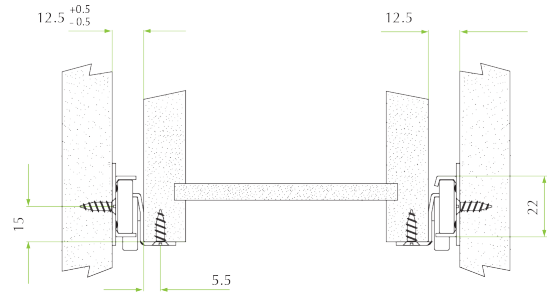
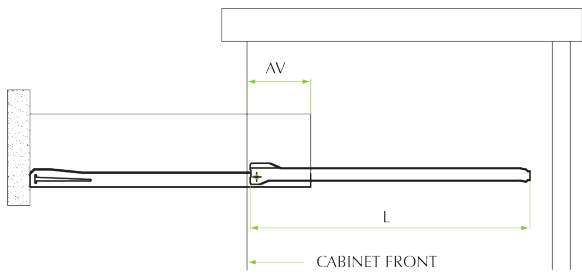

Standard position for the dowels

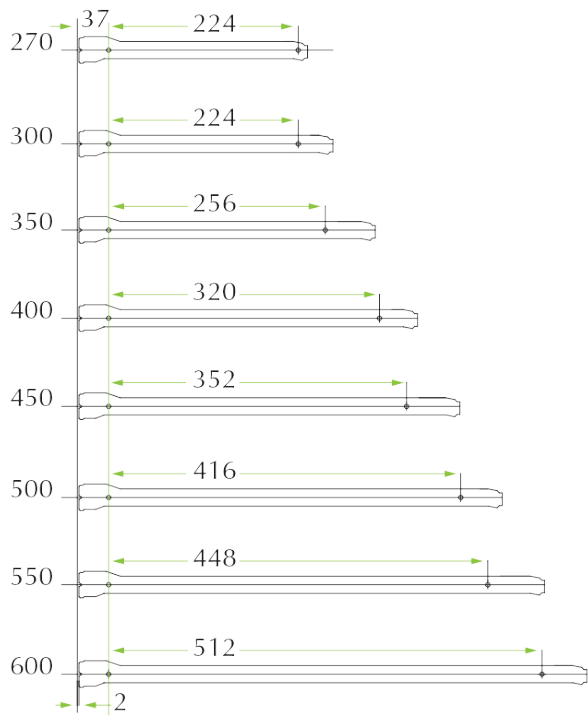

Slides fixing dimensions

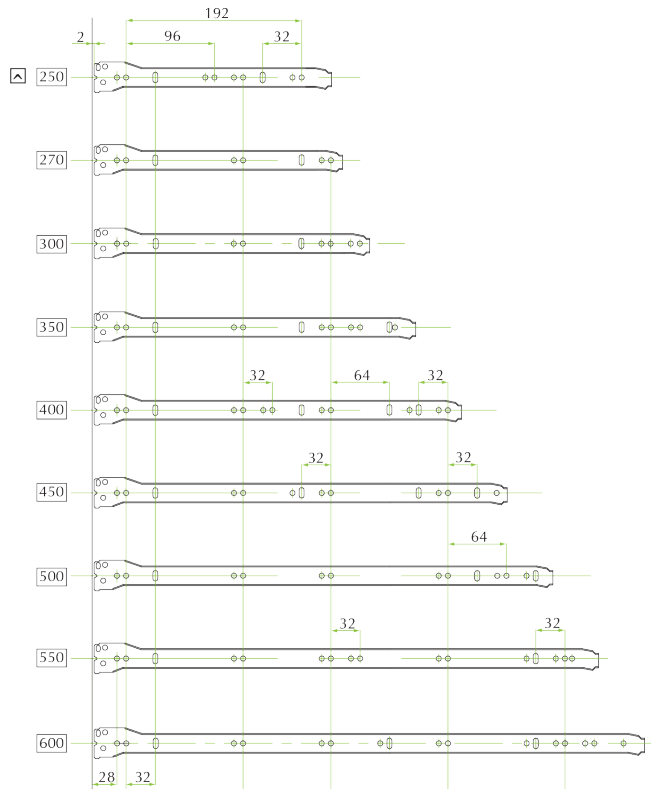

L= Nominal Length AV= Extension Loss

L	270	300	350	400	450	500	550	600
AV	90	90	90	100	100	100	118	118

Tekform Drawers

Bill of Materials - DWD

DWD113 with Square Side Bar				Length	Drawer set	Bracket	Square side bar	
				270mm	650.8027.150	650.8911.150	650.8727.150	
				350mm	650.8035.150	650.8911.150	650.8735.150	
				400mm	650.8040.150	650.8911.150	650.8740.150	
				450mm	650.8045.150	650.8911.150	650.8745.150	
				500mm	650.8050.150	650.8911.150	650.8750.150	
				550mm	650.8055.150	650.8911.150	650.8755.150	
DWD145 with 4mm Glass Sides		Length	Glass finish	Drawer set	Glass sides	Rear connector	Glass clips	Square side bar
		400mm	Frosted Glass	650.8140.150K	650.8404.391	650.8484.350	650.8902.150	650.8740.150
		450mm	Frosted Glass	650.8145.150K	650.8405.391	650.8484.350	650.8902.150	650.8745.150
		500mm	Frosted Glass	650.8150.150K	650.8406.391	650.8484.350	650.8902.150	650.8750.150
		550mm	Frosted Glass	650.8155.150K	650.8407.391	650.8484.350	650.8902.150	650.8755.150
DWD182 with 4mm Glass Sides		Length	Glass finish	Drawer set	Glass sides	Rear connector	Glass clips	Square side bar
		400mm	Frosted Glass	650.8240.150K	650.8440.391	650.8485.350	650.8903.150	650.8740.150
		450mm	Frosted Glass	650.8245.150K	650.8445.391	650.8485.350	650.8903.150	650.8745.150
		500mm	Frosted Glass	650.8250.150K	650.8450.391	650.8485.350	650.8903.150	650.8750.150
		550mm	Frosted Glass	650.8255.150K	650.8455.391	650.8485.350	650.8903.150	650.8755.150
DWD145 with 8mm Glass Sides		Length	Glass finish	Drawer set	Glass sides	Rear connector	Glass clips	
		400mm	Frosted Glass	650.8140.150K	650.8463.391	650.8488.350	650.8902.150	
		450mm	Frosted Glass	650.8145.150K	650.8464.391	650.8488.350	650.8902.150	
		500mm	Frosted Glass	650.8150.150K	650.8465.391	650.8488.350	650.8902.150	
		550mm	Frosted Glass	650.8155.150K	650.8466.391	650.8488.350	650.8902.150	
DWD182 with 8mm Glass Sides		Length	Glass finish	Drawer set	Glass sides	Rear connector	Glass clips	
		400mm	Frosted Glass	650.8240.150K	650.8470.391	650.8489.350	650.8903.150	
		450mm	Frosted Glass	650.8245.150K	650.8471.391	650.8489.350	650.8903.150	
		500mm	Frosted Glass	650.8250.150K	650.8472.391	650.8489.350	650.8903.150	
		550mm	Frosted Glass	650.8255.150K	650.8473.391	650.8489.350	650.8903.150	
DWD Inner Drawer Fronts		Length	Drawer set DW70	Drawer set DW145	Drawer set DW182	Square Front Bar (DW145 / DW182)	Front panel	Front bracket
		270mm	650.8027.150	650.8127.150K	650.8227.150K	650.8604.150	650.8569.150	DW70 (all lengths): 650.8912.350
		350mm	650.8035.150	650.8135.150K	650.8235.150K	650.8604.150	650.8569.150	
		400mm	650.8040.150	650.8140.150K	650.8240.150K	650.8604.150	650.8569.150	DW145 (all lengths): 650.8914.350
		450mm	650.8045.150	650.8145.150K	650.8245.150K	650.8604.150	650.8569.150	
		500mm	650.8050.150	650.8150.150K	650.8250.150K	650.8604.150	650.8569.150	DW182 (all lengths): 650.8916.350
		550mm	650.8055.150	650.8155.150K	650.8255.150K	650.8604.150	650.8569.150	
*with EasyFix front connectors and 1200mm panel width and square bar								
Front panel support clip 002110.885.300 white								

Tekform Drawers

Bill of Materials - Slimline DWD Inner Fronts

Slimline SDWD70 with Aluminium Front			Length	Drawer finish	Drawer set	Front panel	Front bracket	
			270mm	White	655.8T27.150.00	655.8189.511.00	655.8065.150.00	
			350mm	White	655.8T35.150.00	655.8189.511.00	655.8065.150.00	
			400mm	White	655.8T40.150.00	655.8189.511.00	655.8065.150.00	
			450mm	White	655.8T45.150.00	655.8189.511.00	655.8065.150.00	
			500mm	White	655.8T50.150.00	655.8189.511.00	655.8065.150.00	
			550mm	White	655.8T55.150.00	655.8189.511.00	655.8065.150.00	
			270mm	Anthracite	655.8T27.150.00	655.8189.515.00	655.8065.185.00	
			350mm	Anthracite	655.8T35.150.00	655.8189.515.00	655.8065.185.00	
			400mm	Anthracite	655.8T40.150.00	655.8189.515.00	655.8065.185.00	
			450mm	Anthracite	655.8T45.150.00	655.8189.515.00	655.8065.185.00	
			500mm	Anthracite	655.8T50.150.00	655.8189.515.00	655.8065.185.00	
			550mm	Anthracite	655.8T55.150.00	655.8189.515.00	655.8065.185.00	
Slimline SDWD70 with Glass Front		Length	Drawer finish	Glass finish	Drawer set	Front panel	Glass panel	Front bracket
		270mm	White	Transparent	655.8T27.150.00	655.8209.511.00	655.8295.391.00	655.8305.350.00
		350mm	White	Transparent	655.8T35.150.00	655.8209.511.00	655.8295.391.00	655.8305.350.00
		400mm	White	Transparent	655.8T40.150.00	655.8209.511.00	655.8295.391.00	655.8305.350.00
		450mm	White	Transparent	655.8T45.150.00	655.8209.511.00	655.8295.391.00	655.8305.350.00
		500mm	White	Transparent	655.8T50.150.00	655.8209.511.00	655.8295.391.00	655.8305.350.00
		550mm	White	Transparent	655.8T55.150.00	655.8209.511.00	655.8295.391.00	655.8305.350.00
		270mm	Anthracite	Transparent	655.8T27.150.00	655.8209.515.00	655.8295.391.00	655.8305.385.00
		350mm	Anthracite	Transparent	655.8T35.150.00	655.8209.515.00	655.8295.391.00	655.8305.385.00
		400mm	Anthracite	Transparent	655.8T40.150.00	655.8209.515.00	655.8295.391.00	655.8305.385.00
		450mm	Anthracite	Transparent	655.8T45.150.00	655.8209.515.00	655.8295.391.00	655.8305.385.00
		500mm	Anthracite	Transparent	655.8T50.150.00	655.8209.515.00	655.8295.391.00	655.8305.385.00
		550mm	Anthracite	Transparent	655.8T55.150.00	655.8209.515.00	655.8295.391.00	655.8305.385.00

*with EasyFix front connectors and 1200mm panel width

Front panel support clip
002110.885.300 white

Tekform Drawers

Bill of Materials - Slimline DWD Inner Fronts

Slimline SDWD145 with Aluminium Front and Square Bar		Length	Drawer finish	Drawer set	Front panel	Front bar	Front bracket	
		270mm	White	655.8V27.150.00	655.8189.511.00	655.8214.511.00	655.8101.150.00	
350mm	White	655.8V35.150.00	655.8189.511.00	655.8214.511.00	655.8101.150.00			
400mm	White	655.8V40.150.00	655.8189.511.00	655.8214.511.00	655.8101.150.00			
450mm	White	655.8V45.150.00	655.8189.511.00	655.8214.511.00	655.8101.150.00			
500mm	White	655.8V50.150.00	655.8189.511.00	655.8214.511.00	655.8101.150.00			
550mm	White	655.8V55.150.00	655.8189.511.00	655.8214.511.00	655.8101.150.00			
270mm	Anthracite	655.8V27.150.00	655.8189.515.00	655.8214.515.00	655.8101.185.00			
350mm	Anthracite	655.8V35.150.00	655.8189.515.00	655.8214.515.00	655.8101.185.00			
400mm	Anthracite	655.8V40.150.00	655.8189.515.00	655.8214.515.00	655.8101.185.00			
450mm	Anthracite	655.8V45.150.00	655.8189.515.00	655.8214.515.00	655.8101.185.00			
500mm	Anthracite	655.8V50.150.00	655.8189.515.00	655.8214.515.00	655.8101.185.00			
550mm	Anthracite	655.8V55.150.00	655.8189.515.00	655.8214.515.00	655.8101.185.00			
Slimline SDWD145 with Glass Front		Length	Drawer finish	Glass finish	Drawer set	Front panel	Glass panel	Front bracket
		270mm	White	Transparent	655.8V27.150.00	655.8209.511.00	655.8224.391.00	655.8103.350.00
350mm	White	Transparent	655.8V35.150.00	655.8209.511.00	655.8224.391.00	655.8103.350.00		
400mm	White	Transparent	655.8V40.150.00	655.8209.511.00	655.8224.391.00	655.8103.350.00		
450mm	White	Transparent	655.8V45.150.00	655.8209.511.00	655.8224.391.00	655.8103.350.00		
500mm	White	Transparent	655.8V50.150.00	655.8209.511.00	655.8224.391.00	655.8103.350.00		
550mm	White	Transparent	655.8V55.150.00	655.8209.511.00	655.8224.391.00	655.8103.350.00		
270mm	Anthracite	Transparent	655.8V27.150.00	655.8209.515.00	655.8224.391.00	655.8103.385.00		
350mm	Anthracite	Transparent	655.8V35.150.00	655.8209.515.00	655.8224.391.00	655.8103.385.00		
400mm	Anthracite	Transparent	655.8V40.150.00	655.8209.515.00	655.8224.391.00	655.8103.385.00		
450mm	Anthracite	Transparent	655.8V45.150.00	655.8209.515.00	655.8224.391.00	655.8103.385.00		
500mm	Anthracite	Transparent	655.8V50.150.00	655.8209.515.00	655.8224.391.00	655.8103.385.00		
550mm	Anthracite	Transparent	655.8V55.150.00	655.8209.515.00	655.8224.391.00	655.8103.385.00		

*with EasyFix front connectors and 1200mm width

Front panel support clip
002110.885.300 white

Tekform Drawers

Bill of Materials - Slimline DWD Inner Fronts

Slimline SDWD182 with Aluminium Front and Square Bar		Length	Drawer finish	Drawer set	Front panel	Front bar	Front bracket
		270mm	White	655.8Z27.150.00	655.8189.511.00	655.8214.511.00	655.8170.150.00
350mm	White	655.8Z35.150.00	655.8189.511.00	655.8214.511.00	655.8170.150.00		
400mm	White	655.8Z40.150.00	655.8189.511.00	655.8214.511.00	655.8170.150.00		
450mm	White	655.8Z45.150.00	655.8189.511.00	655.8214.511.00	655.8170.150.00		
500mm	White	655.8Z50.150.00	655.8189.511.00	655.8214.511.00	655.8170.150.00		
550mm	White	655.8Z55.150.00	655.8189.511.00	655.8214.511.00	655.8170.150.00		
270mm	Anthracite	655.8Z27.150.00	655.8189.515.00	655.8214.515.00	655.8170.185.00		
350mm	Anthracite	655.8Z35.150.00	655.8189.515.00	655.8214.515.00	655.8170.185.00		
400mm	Anthracite	655.8Z40.150.00	655.8189.515.00	655.8214.515.00	655.8170.185.00		
450mm	Anthracite	655.8Z45.150.00	655.8189.515.00	655.8214.515.00	655.8170.185.00		
500mm	Anthracite	655.8Z50.150.00	655.8189.515.00	655.8214.515.00	655.8170.185.00		
550mm	Anthracite	655.8Z55.150.00	655.8189.515.00	655.8214.515.00	655.8170.185.00		

Slimline SDWD182 with Glass Front		Length	Drawer finish	Glass finish	Drawer set	Front panel	Glass panel	Front bracket
		270mm	White	Transparent	655.8Z27.150.00	655.8209.511.00	655.8284.391.00	655.8172.350.00
350mm	White	Transparent	655.8Z35.150.00	655.8209.511.00	655.8284.391.00	655.8172.350.00		
400mm	White	Transparent	655.8Z40.150.00	655.8209.511.00	655.8284.391.00	655.8172.350.00		
450mm	White	Transparent	655.8Z45.150.00	655.8209.511.00	655.8284.391.00	655.8172.350.00		
500mm	White	Transparent	655.8Z50.150.00	655.8209.511.00	655.8284.391.00	655.8172.350.00		
550mm	White	Transparent	655.8Z55.150.00	655.8209.511.00	655.8284.391.00	655.8172.350.00		
270mm	Anthracite	Transparent	655.8Z27.150.00	655.8209.515.00	655.8284.391.00	655.8172.385.00		
350mm	Anthracite	Transparent	655.8Z35.150.00	655.8209.515.00	655.8284.391.00	655.8172.385.00		
400mm	Anthracite	Transparent	655.8Z40.150.00	655.8209.515.00	655.8284.391.00	655.8172.385.00		
450mm	Anthracite	Transparent	655.8Z45.150.00	655.8209.515.00	655.8284.391.00	655.8172.385.00		
500mm	Anthracite	Transparent	655.8Z50.150.00	655.8209.515.00	655.8284.391.00	655.8172.385.00		
550mm	Anthracite	Transparent	655.8Z55.150.00	655.8209.515.00	655.8284.391.00	655.8172.385.00		

*with EasyFix front connectors and 1200mm width

Front panel support clip
002110.885.300 white