

Furniture Fittings

Furniture Fittings

Product Guide

Overhead Solutions

| | Page |
|--------------------------|------|
| AeroBus Opening System | 3.4 |
| AeroFlap Opening System | 3.6 |
| AeroLoft Opening System | 3.8 |
| AeroSplit Opening System | 3.10 |
| AeroPlus Opening System | 3.12 |
| Lift-up Mechanisms | 3.14 |

Titus Connectors

| | |
|--|------|
| Information | 3.17 |
| System 3 Fittings for face and edge boring | 3.19 |
| System 4 Fittings for face boring only | 3.21 |
| System 5 Cams and dowels | 3.24 |
| System 6 Quickfit-Expando connectors | 3.44 |
| System 7 High strength connectors | 3.53 |

Cabinet and Furniture Legs

| | |
|-------------------------------|------|
| Titus Adjustable Cabinet Legs | 3.57 |
| Decorative Furniture Legs | 3.61 |

Fastmount® Panel Mounting

| | |
|------------------------|------|
| Information | 3.64 |
| Standard Profile Range | 3.65 |
| Low Profile Range | 3.71 |
| Very Low Profile Range | 3.75 |
| Metal Profile Range | 3.78 |
| Panel Control Range | 3.81 |
| Textile Range | 3.82 |
| Installation Tools | 3.84 |
| SuperGroove® Adhesive | 3.85 |

Overhead Solutions

AeroBus Opening System

- Easy assembly with click-on door fixing
- No hinges or stabilisation bars required
- SlowMotion technology for controlled and silent closing
- Compact, non-invasive slim housing
- 3-Way vertical and horizontal adjustment with door weight adjustment



AeroBus Kit for Doors

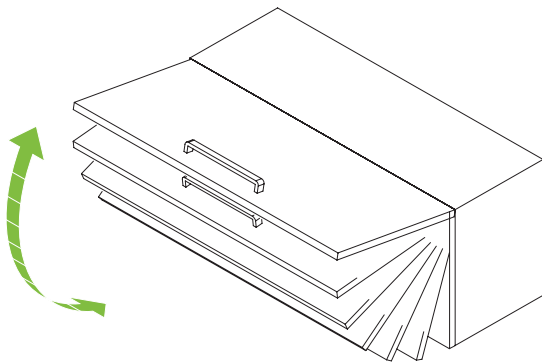

Made of plastic and steel

| Weight (kg) | Item number |
|--|------------------|
| 1.0 - 5.5 | 606.8L03.020.000 |
| 2.4 - 12.3 | 606.8L03.040.000 |
| Kit includes: <ul style="list-style-type: none"> · Symmetrical and dampened mechanisms (2 pcs) · Linear mounting plates for the door fixing (2 pcs) · Ø4 x 15mm screws (6 pcs) · Ø4 x 35mm screws (8 pcs) · Covers: right and left (2 pcs) | |

Choosing the Correct AeroBus System

- Door height max. 400mm
- Door width max. depends on the kit's load capacity
- Choose from 2 kits depending on height and weight requirements

| Door Height (mm) | 606.8L03.020.000 | 606.8L03.040.000 |
|------------------|------------------|------------------|
| 400 | 1.0 - 2.5kg | 2.4 - 5.5kg |
| 350 | 1.1 - 2.9kg | 2.7 - 6.3kg |
| 300 | 1.3 - 3.5kg | 3.2 - 7.4kg |
| 250 | 1.6 - 4.0kg | 3.8 - 8.9kg |
| 200 | 2.0 - 5.0kg | 4.8 - 11.0kg |
| 180 | 2.2 - 5.5kg | 5.3 - 12.3kg |

Overhead Solutions

AeroBus Opening System

Application

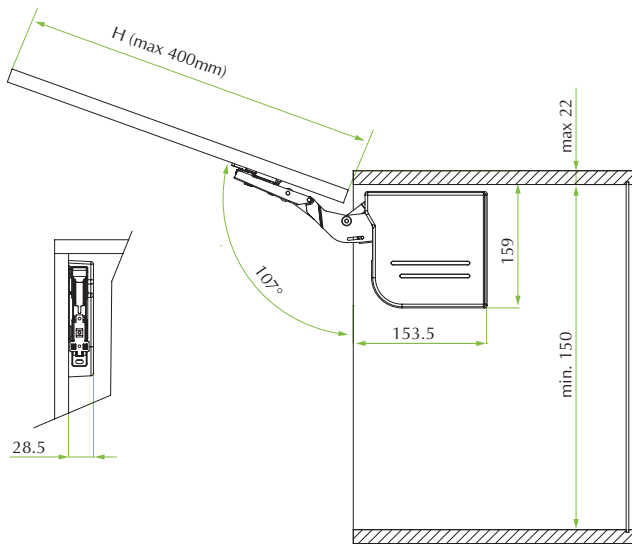

Cabinet Fixing

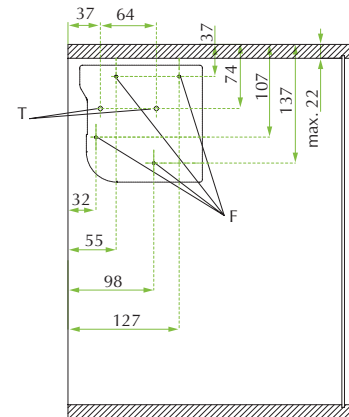

5 min.
 $\varnothing 5$
 "T"
 T = $\varnothing 5$ mm x min. 5mm deep
 T = pilot holes
 F = fixing holes

Door Fixing

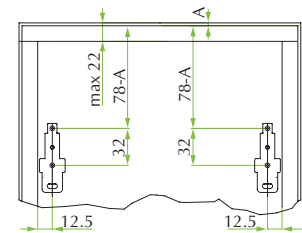

Adjustments

Door Adjustment

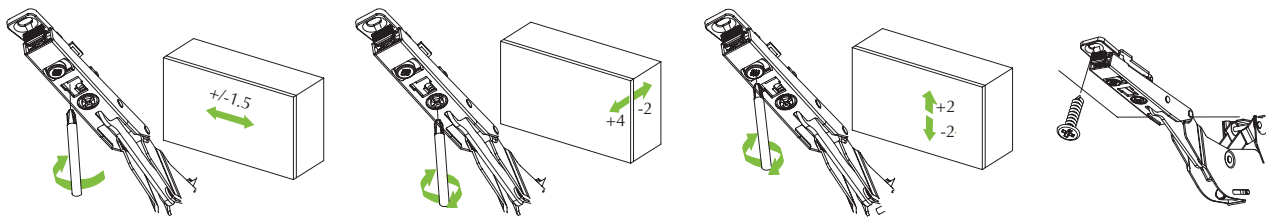

Damper Strength Adjustment

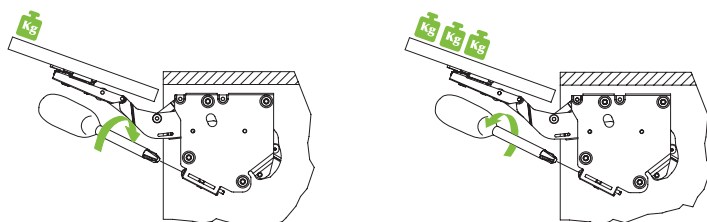

Overhead Solutions

AeroFlap Opening System

- Door moves above cabinet opening
- Perfect pause in every opening position
- 30 adjustments for door positioning
- SlowMotion technology for controlled and silent closing



| Door height (mm) | Door weight (kg) | Item number |
|--|------------------|------------------|
| 450 | 4.8-5.7 | 606.8L09.010.660 |
| 600 | 4.4-5.2 | |
| 660 | 4.0-4.7 | |
| 450 | 5.8-7.3 | 606.8L09.020.660 |
| 600 | 5.3-6.7 | |
| 660 | 4.8-6.2 | |
| 450 | 7.4-9.2 | 606.8L09.030.660 |
| 600 | 6.8-8.4 | |
| 660 | 6.3-7.9 | |
| 450 | 9.3-10.8 | 606.8L09.040.660 |
| 600 | 8.5-9.9 | |
| 660 | 8.0-9.3 | |
| 450 | 10.9-14.5 | 606.8L09.050.660 |
| 600 | 10.0-13.0 | |
| 660 | 9.4-11.8 | |
| 720 | 7.9-9.3 | 606.8L09.130.800 |
| 800 | 7.7-8.9 | |
| 720 | 9.5-12.0 | 606.8L09.140.800 |
| 800 | 9.0-11.4 | |
| Stabilisation bar, 1200mm → Order separately 606.8L09.150.200 | | |
| Kit includes: <ul style="list-style-type: none"> · 2 mechanisms, RH & LH · 2 dampers for mechanisms · 2 covers, RH & LH · 14 Euro screws, Ø6 x 12mm · 12 self-tapping screws, Ø4 x 35mm · Assembly instructions | | |

Overhead Solutions

AeroFlap Opening System

Application

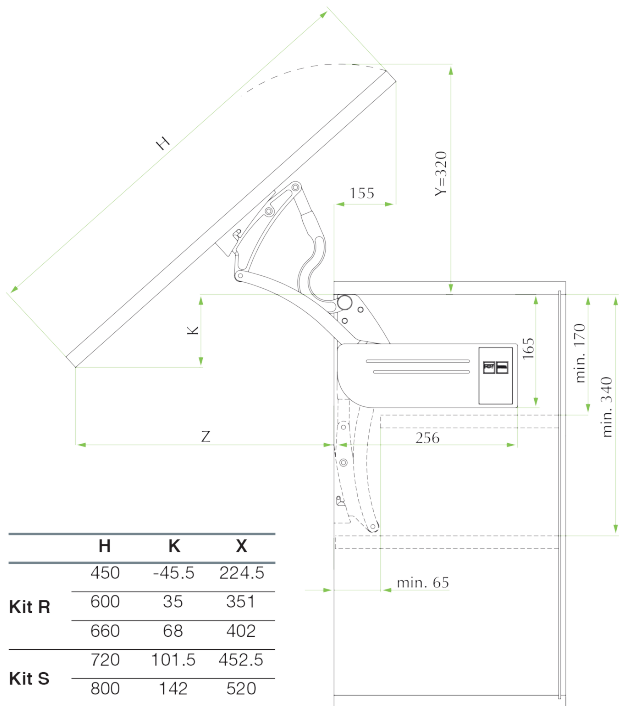

Cabinet Fixing

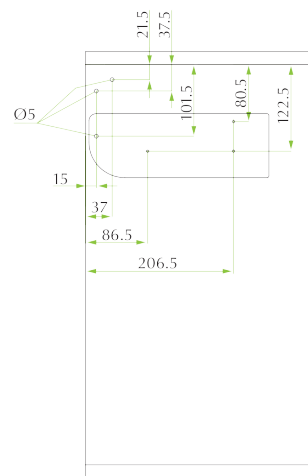

Door Fixing

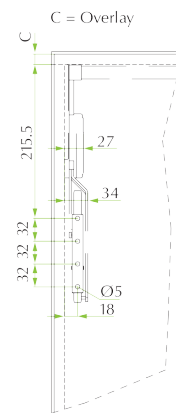

Adjustments

Door Adjustment

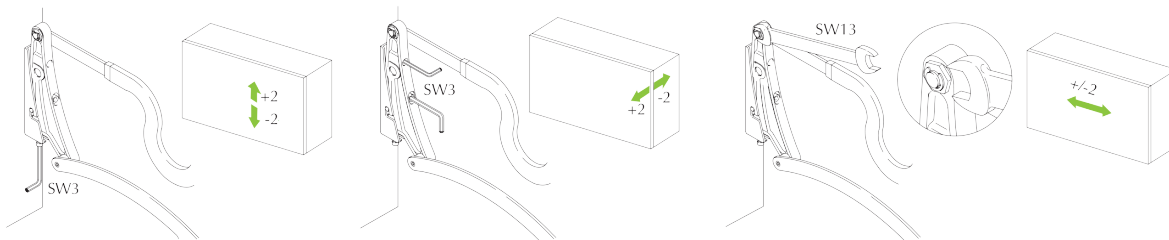

Weight Adjustment

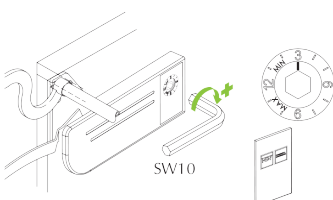

Overhead Solutions

AeroLoft Opening System

- Compact & non-invasive system
- Easy mounting on the cabinet and rapid fixing on the door with a 'click' and without hinges
- SlowMotion technology for a controlled and silent closing
- 3-Way vertical and horizontal adjustment with door weight adjustment

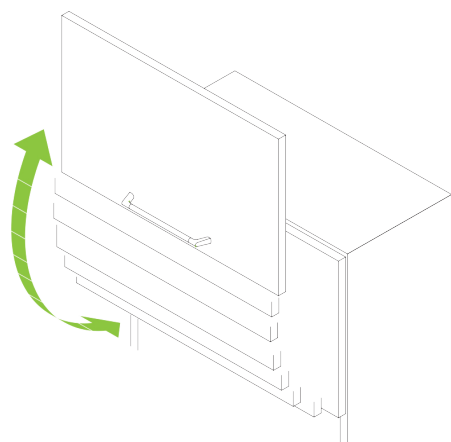

| Door height (mm) | Door weight (kg) | Item number |
|------------------|------------------|------------------|
| 380-500 | 4.8-6.0 | 606.8L09.210.500 |
| 450-580 | 4.7-5.9 | 606.8L09.250.250 |
| 450-580 | 6.0-7.6 | 606.8L09.310.058 |
| 450-580 | 7.7-9.2 | 606.8L09.320.058 |

Kit includes:

- 2 mechanisms, RH & LH
- 2 dampers for mechanisms
- 2 covers, RH & LH
- 14 Euro screws, Ø6x12mm
- 12 self-tapping screws, Ø4x35mm
- Assembly instructions

Stabilisation bar, 1200mm

→ Order separately 606.8L09.150.020

Overhead Solutions

AeroLoft Opening System

Application

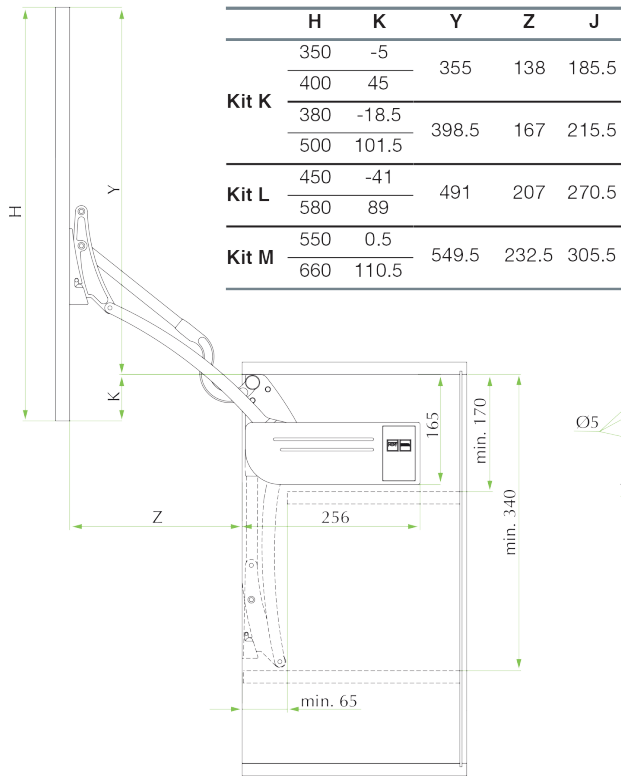

Cabinet Fixing

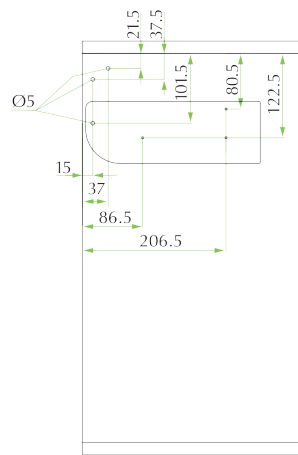

Door Fixing

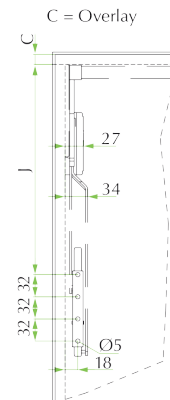

Adjustments

Door Adjustment

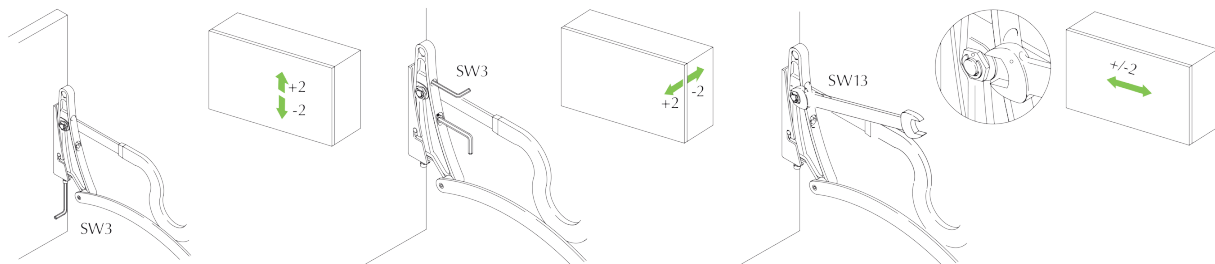

Weight Adjustment

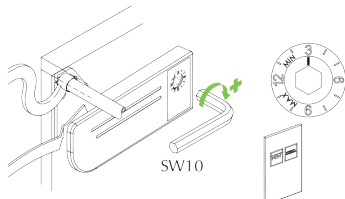

Overhead Solutions

AeroSplit Opening System

- Door bi-folds up
- 125° folding door opening operation, ensuring the second half of the door folds extremely flat
- Anti-pinch central hinge for safe functioning
- No stabilisation bar required
- Perfect pause in every position
- SlowMotion technology for controlled and silent closing

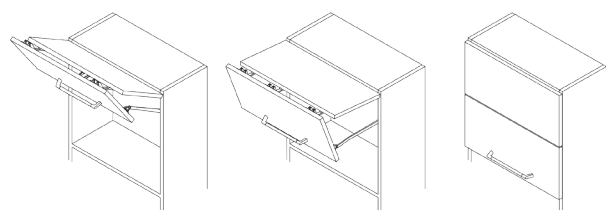

| Door height (mm) | Door weight (kg) | Item number |
|------------------|------------------|------------------|
| 600 | 6.8-8.1 | 606.8L09.510.060 |
| 600 | 8.2-10.0 | 606.8L09.520.060 |
| 720 | 6.6-8.7 | 606.8L09.610.072 |
| 720 | 8.8-11.0 | 606.8L09.620.072 |
| 720 | 11.1-13.3 | 606.8L09.630.072 |
| 800 | 10.1-12.5 | 606.8L09.730.080 |
| 800 | 12.6-13.5 | 606.8L09.740.080 |

Kit includes:

- 2 mechanisms, RH & LH
- 2 dampers for mechanisms
- 2 covers, RH & LH
- 14 Euro screws, Ø6 x 12mm
- 12 self-tapping screws, Ø4 x 35mm
- Assembly instructions

Note: Hinge 110° not included

Overhead Solutions

AeroSplit Opening System

Application

| | H | K | Y | Z | T | V | U | X |
|--------------|-----|-----|-------|-----|-----|-----|-----|-----|
| Kit A | 600 | 75 | 161 | 383 | 314 | 335 | 356 | 270 |
| Kit B | 720 | 91 | 181 | 450 | 367 | 388 | 409 | 323 |
| Kit C | 800 | 119 | 210.5 | 468 | 398 | 419 | 440 | 354 |

Application 125°:

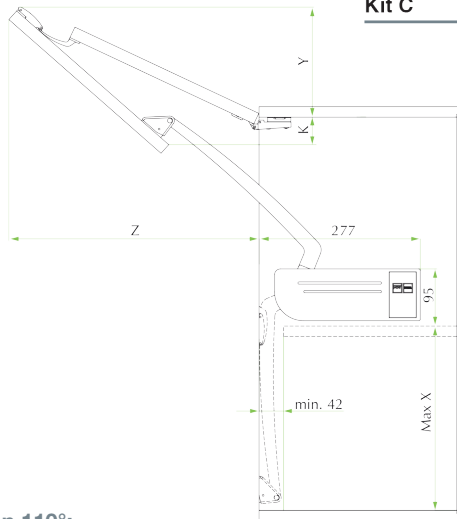

Cabinet Fixing

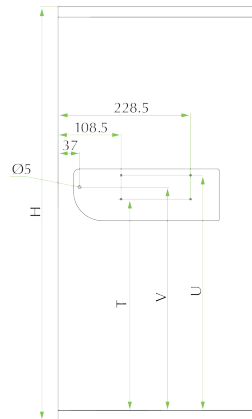

Door Fixing

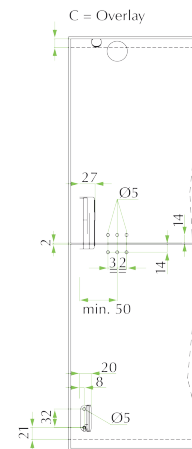

Application 110°:

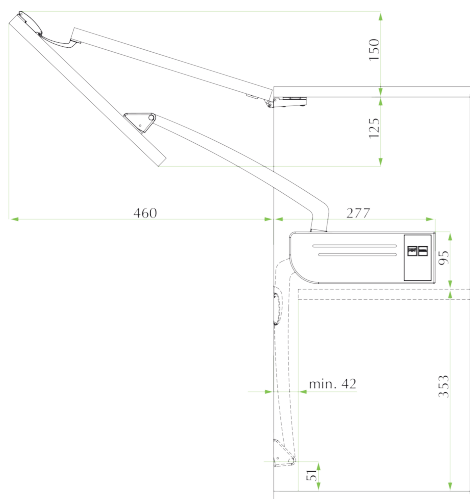

Cabinet Fixing

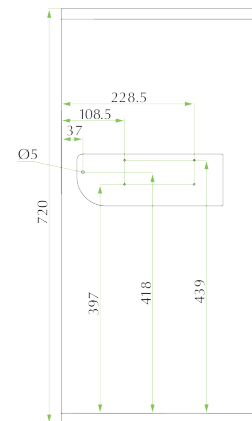

Door Fixing

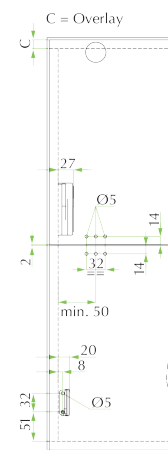

Adjustments

Weight Adjustment

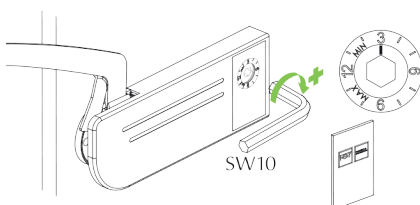

Overhead Solutions

AeroPlus Opening System

- Upwards operation
- Symmetrical mechanism for smart assembly
- Adjustable for doors up to 20kg
- Perfect stay in all positions
- 32mm standard cabinet drilling
- Combine with soft close hinges for smooth operation



Item number

606.8L09.900.110

Kit includes:

- 1 AeroPlus joint
- 1 cover cap
- 1 bracket for cabinet
- 1 bracket for wooden door
- Assembly instructions

Note: Hinge 110° not included

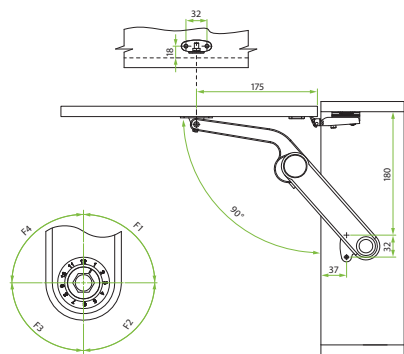

Overhead Solutions

AeroPlus Opening System

Application

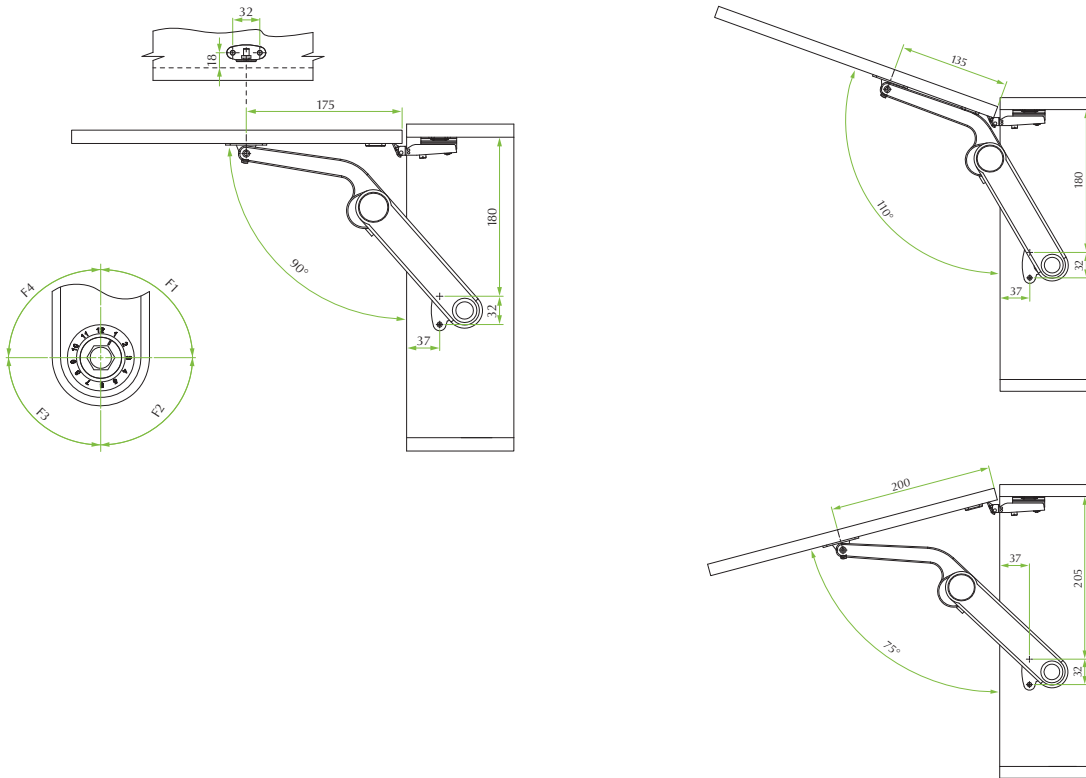





Adjustments

Door Adjustment (kgs)

| Door Height | F1 1-2-3 | F2 4-5-6 | F3 7-8-9 | F4 10-11-12 |
|-------------|-------------|-------------|-------------|----------------|
| 300 | 3 - 5 | 5 - 10 | 9 - 15.5 | 11 - 20 |
| 400 | 2 - 4 | 3.5 - 7.5 | 6.5 - 11.5 | 8.5 - 15 |
| 500 | 1.5 - 3 | 3 - 6 | 5.5 - 9.5 | 7 - 12 |
| 600 | 1.5 - 2.5 | 2.5 - 5 | 4.5 - 7.5 | 6 - 10 |

Overhead Solutions

Lift-up Mechanisms

| | Dimensions (mm) | Item number | Silver | White | Chrome |
|--|---|-----------------------|--------|-------|--------|
| Gas Strut  | Minimum internal cabinet height 264mm | 606.8L03.300 → | 287 | | |
| | <ul style="list-style-type: none"> Gas Strut suitable for weights up to 12kg | | | | |
| Lift-up Stay  | | 606.8L03.287 → | | 000 | |
| | <ul style="list-style-type: none"> Lift-up overhead stay with easy operation and variable opening angle of 75°. No concealed hinges required on top panel. Spring strength of 180N | | | | |
| Flap Stay with Catch  | 225 | 605.8A20.225 → | | 001 | |
| Klok XL Flap Stay  | Minimum door height 300mm Maximum door height 700mm Maximum door opening angle 105° | 606.8L03.001 → | | | 000 |
| | <ul style="list-style-type: none"> Klok XL Flap Stay complete with carcase bracket and door bracket for wood <p>Details on how many flap stays are required depending on door height, weight and desired opening angle → see page 3.15</p> | | | | |

Overhead Solutions

Klok XL Flap Stay

Choosing the Correct Quantity of Klok XL Flap Stays

To keep the door opening in any position, the number of Klok XL flap stays to use must be calculated according to the door weight, the door height and the maximum opening angle desired.

| Door weight and maximum opening angle | | Door height (mm) | | | | | | | | |
|---------------------------------------|------|------------------|-----|-----|-----|-----|-----|-----|-----|-----|
| | | 300 | 350 | 400 | 450 | 500 | 550 | 600 | 650 | 700 |
| 2kg | 75° | 1 | 1 | 1 | 1 | 1 | 1 | 1 | 1 | 1 |
| | 90° | 1 | 1 | 1 | 1 | 1 | 1 | 1 | 2 | 2 |
| | 105° | 1 | 1 | 1 | 1 | 1 | 2 | 2 | 2 | 2 |
| 3kg | 75° | 1 | 1 | 1 | 1 | 1 | 1 | 1 | 1 | 1 |
| | 90° | 1 | 1 | 1 | 1 | 1 | 1 | 1 | 2 | 2 |
| | 105° | 1 | 1 | 1 | 1 | 1 | 2 | 2 | 2 | 2 |
| 4kg | 75° | 1 | 1 | 1 | 1 | 1 | 1 | 1 | 1 | 1 |
| | 90° | 1 | 1 | 1 | 1 | 1 | 1 | 1 | 2 | 2 |
| | 105° | 1 | 1 | 1 | 1 | 1 | 2 | 2 | 2 | 2 |
| 5kg | 75° | 1 | 1 | 1 | 1 | 1 | 1 | 1 | 1 | 1 |
| | 90° | 1 | 1 | 1 | 1 | 1 | 1 | 1 | 2 | 2 |
| | 105° | 1 | 1 | 1 | 1 | 2 | 2 | 2 | 2 | 2 |
| 6kg | 75° | 1 | 1 | 1 | 1 | 1 | 1 | 1 | 1 | 1 |
| | 90° | 1 | 1 | 1 | 1 | 1 | 2 | 2 | 2 | 2 |
| | 105° | 1 | 1 | 1 | 2 | 2 | 2 | 2 | 2 | 2 |
| 7kg | 75° | 1 | 1 | 1 | 1 | 1 | 1 | 1 | 2 | 2 |
| | 90° | 1 | 1 | 1 | 2 | 2 | 2 | 2 | 2 | 2 |
| | 105° | 1 | 2 | 2 | 2 | 2 | 2 | 2 | 2 | / |
| 8kg | 75° | 1 | 1 | 1 | 1 | 1 | 2 | 2 | 2 | 2 |
| | 90° | 1 | 1 | 2 | 2 | 2 | 2 | 2 | 2 | 2 |
| | 105° | 1 | 2 | 2 | 2 | 2 | 2 | 2 | / | / |
| 9kg | 75° | 1 | 1 | 1 | 1 | 2 | 2 | 2 | 2 | 2 |
| | 90° | 1 | 2 | 2 | 2 | 2 | 2 | 2 | 2 | / |
| | 105° | 2 | 2 | 2 | 2 | 2 | / | / | / | / |
| 10kg | 75° | 1 | 1 | 1 | 2 | 2 | 2 | 2 | 2 | 2 |
| | 90° | 1 | 2 | 2 | 2 | 2 | 2 | 2 | / | / |
| | 105° | 2 | 2 | 2 | 2 | / | / | / | / | / |
| 11kg | 75° | 1 | 1 | 2 | 2 | 2 | 2 | 2 | 2 | 2 |
| | 90° | 2 | 2 | 2 | 2 | 2 | / | / | / | / |
| | 105° | 2 | 2 | 2 | / | / | / | / | / | / |
| 12kg | 75° | 1 | 1 | 2 | 2 | 2 | 2 | 2 | 2 | 2 |
| | 90° | 2 | 2 | 2 | 2 | 2 | / | / | / | / |
| | 105° | 2 | 2 | 2 | / | / | / | / | / | / |

Titus Connectors

Why Choose Titus Connectors

Titus connectors add value to furniture and to furniture manufacturing

Titus connectors improve the quality of furniture and lower the cost of manufacturing and assembly while ensuring a high degree of customer satisfaction.

The most advanced range of connectors available on the market

Precise and efficient product design. **The broadest possible range of drilling tolerances** ensures reliable assembly and consistently strong joints. **Klix** locking feature, the engagement of interlocking teeth on cam and dowel, to prevent joint loosening in service or transit. **Expanding function** provides degrees of variation in out-of-tolerance drillings ensuring stronger joints and improved quality of furniture. **Twinstart thread** for faster and more stable insertion. **Depth stop collar** prevents over-insertion. **Firm tightening** for greater confidence in use. **Cam locks at 230°** ensuring a smooth tightening action and greater dowel pull-up.

Quickfit for hand dowel insertion. **Quickfit TL2, TL4** with the built-in self adjustment feature is the only available dowel that allows for pre-insertion. **Quickloc** one-piece fitting for faster assembly with integrated expanding cam and dowel. **Zinc+steel dowel** for optimal strength and performance. **Precise dowel manufacturing** high precision of zinc and strength of steel assures 100% dimensional accuracy.

Easy and quick consumer friendly self-assembly of furniture

Self-assembly furniture offers consumers good value and instant availability of products.

With the aim of providing consumers with simpler instructions, fewer parts and an easier assembly process, Titus has significantly reduced and simplified the number of fittings traditionally required in furniture production.

Titus connectors provide consumers with easy assembly, and furniture producers with increased productivity through:

- Reduced number of assembly parts
- Easy assembly instructions
- Security of packed parts during transit

CAF Quick & Easy

Consumer Assembly Friendliness

Connectors Information

Easy and Quick Furniture Assembly

CAF formula

CAF = Consumer Assembly Friendliness

Titus CAF formula provides a comparative measure for customer satisfaction. By using it, manufacturers are able to evaluate their products internally or against those of their competitors. While offering consumers easier and faster assembly, there are obvious advantages also for furniture manufacturers – buying, counting, bagging and stocking of fittings can be greatly reduced.

$$\begin{array}{l}
 \text{T} \text{ Total quantity} + \text{A} \text{ Actions} \times \text{N} \text{ Number of} \\
 \text{of parts} \quad \text{to assemble} \quad \text{types of parts} \\
 \begin{array}{cccccc}
 \text{6} & \text{3} & \text{7} & & & \\
 \text{6} & \text{1} & \text{5} & \text{7} & \text{2} & \text{4} \\
 \text{1} & \text{6} & \text{9} & \text{1} & \text{1} & \\
 \text{6} & \text{2} & \text{1} & \text{5} & \text{4} & \text{9}
 \end{array}
 \end{array}$$

$$\begin{array}{cccccc}
 \text{1} & \text{2} & \text{3} & \text{4} & \text{5} & \text{6} \\
 \text{1} & \text{2} & \text{3} & \text{4} & \text{5} & \\
 \text{1} & \text{2} & \text{3} & \text{4} & & \\
 \text{1} & \text{2} & \text{3} & & & \\
 \text{1} & & & & & \\
 \text{1} & & & & &
 \end{array}$$

$$\text{(T+A)N} = \text{CAF}$$

Minimise the numbers in the Titus CAF™ formula to achieve:

- High customer satisfaction
- Improved productivity
- Higher profits

How does it work?

Comparative CAF scores to assemble a hand held demonstrator:

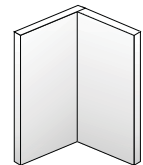

| | T | A | N | CAF |
|---|---|----|---|-----|
| Connecting screw (traditional assembly) | 4 | 38 | 3 | 126 |
| Cam & dowel with single start thread | 6 | 21 | 4 | 108 |
| Cam & dowel with twinstart thread | 6 | 15 | 4 | 84 |
| Cam & TL2 dowel (self-assembly) | 6 | 7 | 4 | 52 |
| Cam & TL2 dowel (factory pre-inserted) | 2 | 3 | 2 | 10 |
| Quickloc | 2 | 3 | 1 | 5 |
| Fully assembled demonstrator | 1 | 0 | 1 | 1 |

System 3

Fittings for Face and Edge Boring

System Features

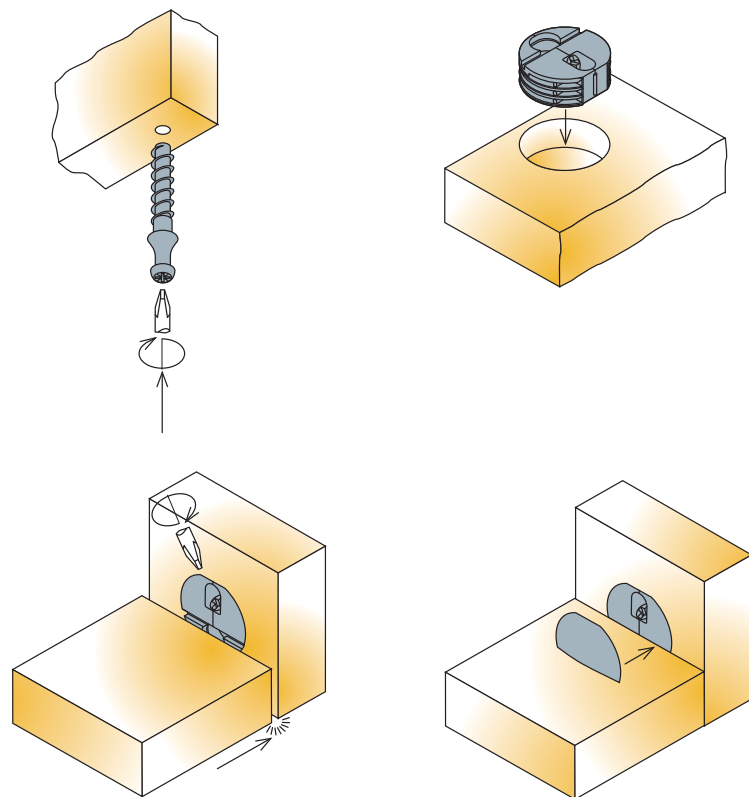

Titus System 3 is a two component rigid face and edge drilled fastening with half turn to fasten. System 3 offers almost full concealment and wide tolerances in use.

- Automatic or in-factory placement
- Pre-located pin ensures ease of assembly
- Less than one turn of a screwdriver to fasten
- Shelf edge installation of pin means maximum shelf cut size tolerance
- Can be used on 12mm shelf panels
- No loose parts for maximum convenience in RTA
- Drawer front fixing, cabinet construction

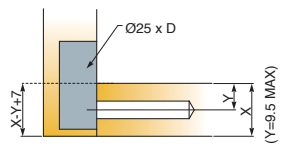
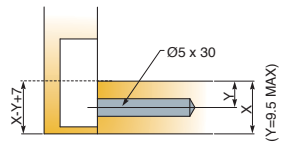
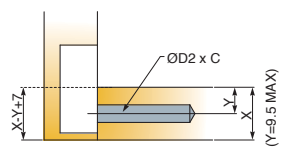

System 3 Fittings for Face and Edge Boring Concealed Housing

- One turn locking system reduces assembly time, both in the factory and home
- Pre-assembly feature for consumer convenience
- Choice of dowels to suit drilling
- Hi-Lo screw feature for faster insertion

| | | C | D | D2 | | | | | |
|--------------------------------|--|--------------------------------|---------------------|---|-------------|-------|-------------|------------------|-------|
| Technical and mounting details | | Drilling length for dowel (mm) | Drilling depth (mm) | Drilling diameter for dowel thread (mm) | Item number | Black | Zinc plated | Yellow passivate | White |
| Housing Assembly |  <p>X, Y - depends on board thickness</p> | 12.5 | | | 03118 → | 835 | | | 877 |
| | | 11 | | | 03121 → | 835* | | | |
| · Other colours on request | | | | | | | | | |
| Made of plastic and zinc | | | | | | | | | |
| Screw Dowel Ø5 |  <p>X, Y - depends on board thickness</p> | | | | 03168 → | | 883 | | |
| Made of steel | | | | | | | | | |
| Screw Dowel Ø3 |  <p>X, Y - depends on board thickness</p> | 30 | | 3.75 | 03181 → | | | | 881* |
| | | 9 | | 3 | 03180 → | | | | 881* |
| Made of steel | | | | | | | | | |
| Cover Cap |  | | | | 03150 → | 835 | | | 877 |
| · Other colours on request | | | | | | | | | |
| Made of plastic | | | | | | | | | |

System 4 Fittings for Face Boring Only

System Features

Cost effective one-piece fittings with face-boring benefits:

- Flush and block components
- Face-boring only
- Good tolerances
- One-piece connectors
- Angledrive versions fasten with maximum driving power and flexibility
- Quickloc™ versions need only one turn to tighten for fast assembly
- Foolproof consumer home insertion

Quickloc™ One-piece Connector

The integrated housing and dowel make Quickloc™ the most user-friendly and tolerant product available.

- High degree of drilling tolerance
- Push-in design
- Toolless insertion
- Integrated expanding housing and dowel provide consistently stronger joints

Quickloc™ Assembly

1. Press Quickloc into the face board 2. Assemble the panels

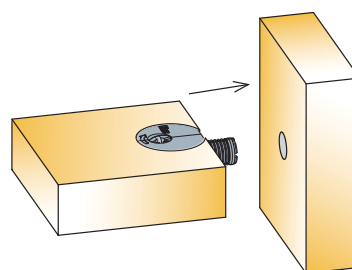
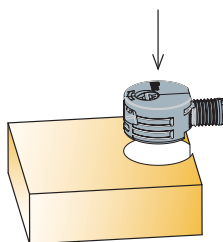

3. Tighten in less than one turn

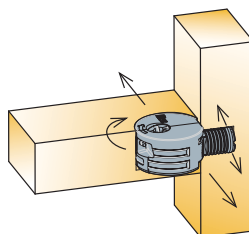

System 4 Quickloc™ One-piece Expanding Connector

- An innovative, one-piece connector, capable of hand insertion
- Is highly tolerant and tightens in less than one turn
- Is a face-bored product
- Offers a high degree of drilling tolerance and is the only connector of its type to provide pull-up of cabinet panels when tightened



Technical and mounting details

| Item number | Colour | | |
|-------------|------------|-------|-------|
| | Dark brown | Black | White |

Quickloc Ø20 Flanged

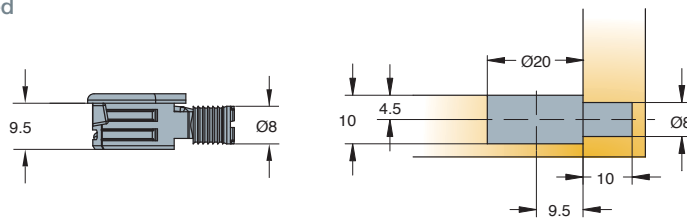

Made of plastic and zinc

| | | | |
|---------|------|------|------|
| 06803 → | 831* | 835* | 877* |
|---------|------|------|------|

Quickloc Ø20 Flush

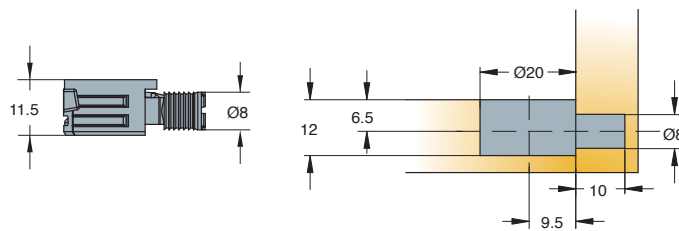

Made of plastic and zinc

| | | | |
|---------|-----|-----|-----|
| 06806 → | 831 | 835 | 877 |
|---------|-----|-----|-----|

· Other colours on request

Quickloc Ø25 Flanged

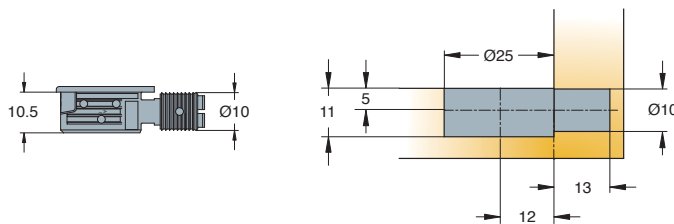

Made of plastic and zinc

| | | | |
|---------|------|------|------|
| 06813 → | 831* | 835* | 877* |
|---------|------|------|------|

Quickloc Ø25 Flush

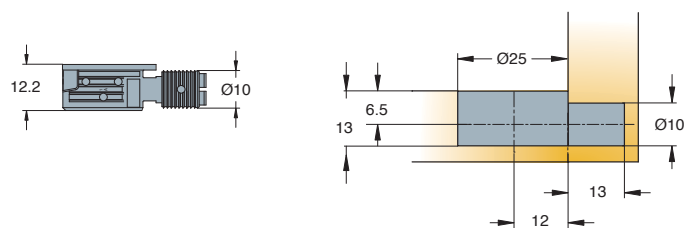





Made of plastic and zinc

| | | | |
|---------|------|------|-----|
| 06839 → | 831* | 835* | 877 |
|---------|------|------|-----|

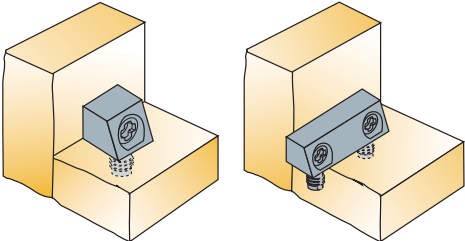
System 4 Fittings for Face Boring Only Minibloc™ / Twinbloc™

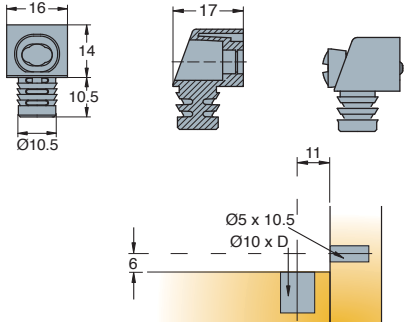
- One-piece connector range
- Face drilling only required
- Easy to use, foolproof home insertion
- Angledrive screw tolerates good levels of inaccurate drilling, increasing consumer confidence

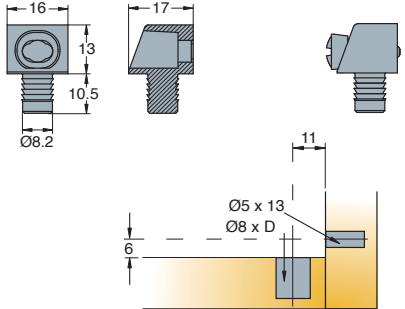
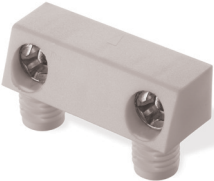
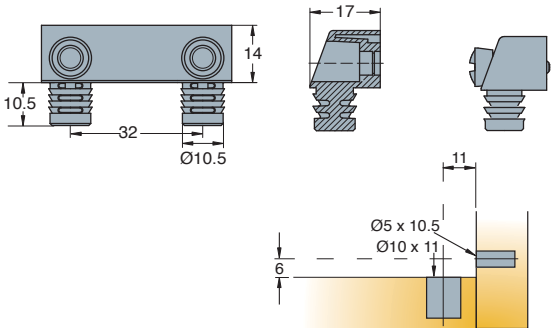
| | |  | | | | | |
|---|---|---|----------|--------|-------|------|------|
| | | Dark brown | Black | Silver | White | | |
| D | | | | | | | |
| Drilling depth (mm) | | | | | | | |
| Item number | | | | | | | |
|  <p>Technical and mounting details</p> | | | | | | | |
| Minibloc Ø10 |   <p>Made of plastic and zinc</p> | 11 | 02107 → | 831* | 835* | 861* | 877* |
| | | 11 | ^02120 → | 831* | 835* | 861* | 877* |
| | | ^Assembly with screw • Other colours on request | | | | | |
| Minibloc Ø8 |   <p>Made of plastic and zinc</p> | 11 | 02141 → | | 835* | 861* | 877* |
| | | • Other colours on request | | | | | |
| Twinbloc Ø10 |   <p>Made of plastic and zinc</p> | 11 | 02130 → | | 835* | 861* | 877* |
| | | 11 | ^02139 → | | 835* | | 877* |
| | | ^Assembly with screw • Other colours on request | | | | | |

System 5 Cams and Dowels

System Features

The most advanced cam and dowel range

Titus System 5 is a comprehensive range of cam and dowel connecting fittings with 'Klix' and Quickfit features for all cabinet applications: panel-to-panel, panel-to-hollow profile and back-to-back

Dowels

- **Quickfit TL5, 'Full metal jacket'**
Toolless insertion technology for Ø5mm dowel holes
- **Quickfit TL2, TL4, TL5 dowels**
A unique solution for factory pre-insertion, high level of drilling tolerances

- **Quickfit dowels**
Quick hand insertion, easy assembly
- **Diecast dowels (zinc)**
Precise manufacturing, optimal shape and design
- **Turned dowels (steel)**
'Traditional' design, smooth surface and best strength performance
- **Combi dowels (zinc and steel)**
High precision of zinc, strength of steel, 100% dimensional accuracy and optimal performance

Titus 'Klix'™

Titus 'Klix' locking system ensures the engagement of the interlocking teeth on cam and dowel, providing:

- Vibration-proof joint
- Rigid construction that will not loosen in service or transit

Dowel insertion time comparison

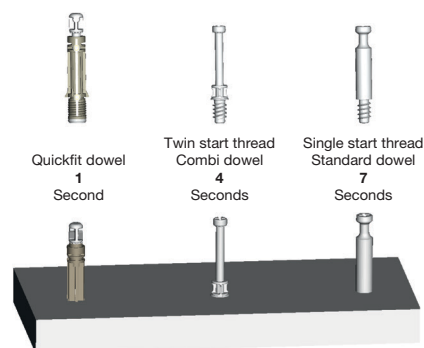

2 o'clock lock smooth closing

Linear cam profile assures smooth, firm tightening action and greater pull-up. The cam always locks at 2 o'clock lock (230°), enabling greater consumer confidence in use while improving furniture quality.

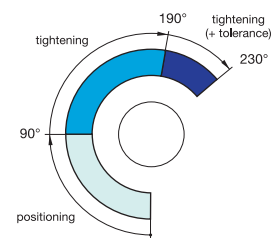

System 5 Cams and Dowels

Drilling tolerances

Optimal performance and perfect joint even with inaccurate drillings.

Zinc/Combi dowel

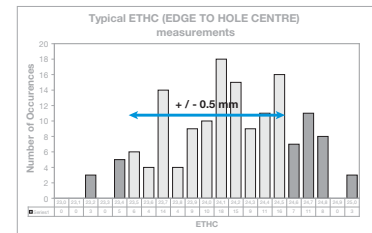
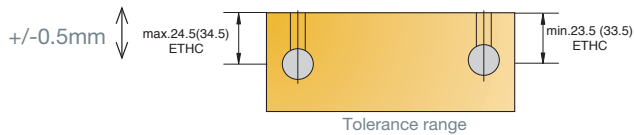

Quickfit TL5 dowel Quickfit TL2 dowel

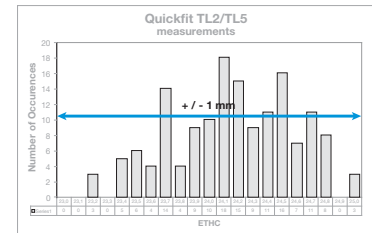
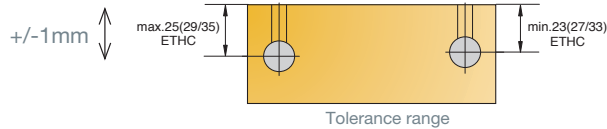

Quickfit TL4 dowel

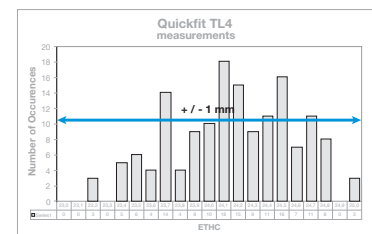
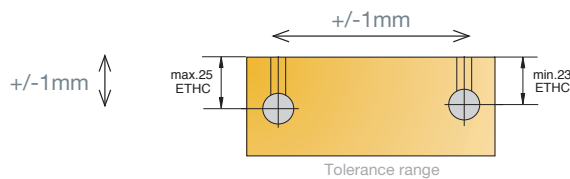

ETHC=Edge To Hole Center

Dowels for factory insertion

Quickfit TL5, Quickfit TL2 and Quickfit TL4 are the only available dowels that allow for factory pre-insertion, enabling:

- Easier packing
- Less damages in handling
- Perfect for the RTA market

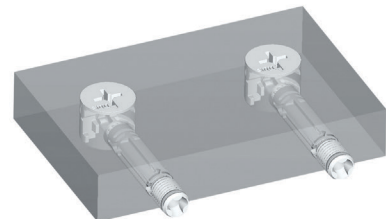

System 5

Cams and Dowels

Cam5000

Universal cam

New Cam5000 works with all Titus parallel neck dowels enabling simple stock management and greater confidence in use.

Highly resistant central shape

Shape of the cam body is redesigned to prevent the cam toroidal deformation or breakage in panel while tightening. The Cam5000 high resistance enables a strong and reliable joint.

Linear cam profile

Linear cam profile ensures:

- Smooth tightening action
- Greater dowel pull-up

Optimised cam profile

Optimised cam profile ensures a smooth and tight joint with no gap between panels.

2 o'clock lock

The cam always locks at 2 o'clock lock (230°), enabling greater consumer confidence in use while improving furniture quality.

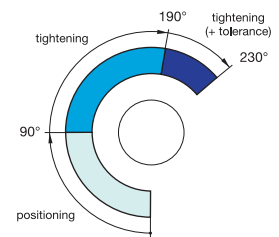

Cam retaining pips

Cam retaining pips assures:

- The cam is held in position prior to assembly
- Secure cam positioning during transport and handling
- Accurate factory insertion



System 5 Cams and Dowels

Zinc+steel Combi Dowels

Zinc+steel technology for optimal strength and performance

The Combi dowel combines steel and a small amount of zinc to ensure high precision and dimensional accuracy, essential to provide furniture manufacturers with the broadest possible range of drilling tolerances.

Toroidal head form

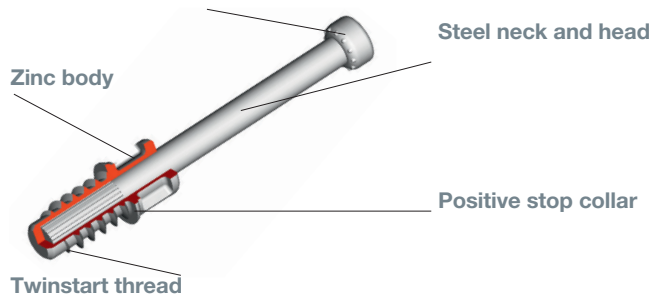

The steel neck and head provide better resistance to torsion and pull-out enabling a high performance joint.

Zinc body:
Positive stop collar ensures correct insertion depth.
Twinstart for faster and more stable insertion.

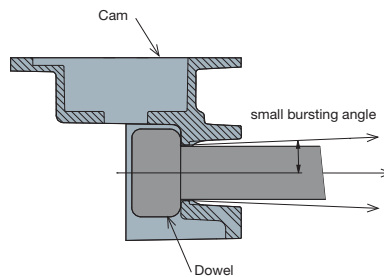

The toroidal dowel head form transfers the forces between cam and dowel more effectively resulting in a small cam bursting force.

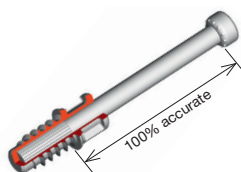

100% dimensional accuracy assured.

System 5 Cams and Dowels

Quickfit Connectors

It is the fastest assembly system on the market. The Quickfit™ dowel may be inserted by hand, using only finger pressure. This eliminates the labour intensive process of screw-in assembly and the potential panel damage.

The Quickfit™ range of dowels has been extended to provide a complete family of fittings available in diameters of 5mm, 8mm and 10mm and lengths of 24mm and 34mm. These dowels are compatible with the range of Titus Ø15mm cams.

Assembly

1. Press the cam into face board

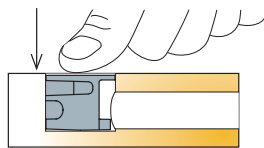

2. Insert the dowel into side panel

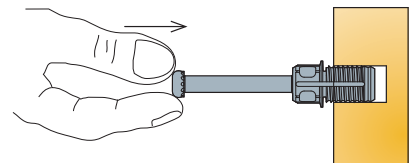

3. Assemble the panels

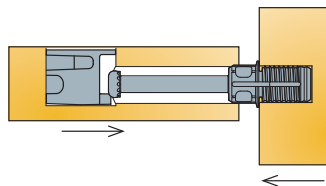

4. Tighten the cam to lock dowel

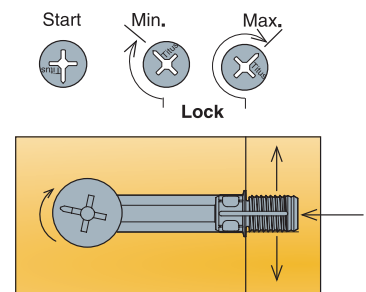

5. Assembled panels

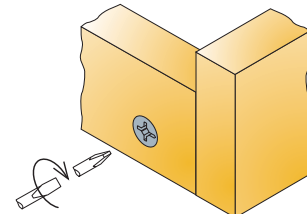

System 5 Cams and Dowels

Quickfit TL Connectors

Quickfit-TL™ dowel offers furniture manufacturers a fast assembly system providing high drilling tolerances. It has a built-in self-adjustment feature, which enables common drilling inaccuracies to be overcome.

For the self-assembly furniture consumer, Titus Quickfit-TL™ is the most consumer friendly fitting on the market. Apart from the benefit of fully tightened joints and easy locking into the same position, Quickfit-TL™ provides an exceptionally smooth action when tightened, requiring very little effort.

Drilling tolerances

Marginal inconsistencies of drilling and the problems associated with the natural movement of wood panels, no longer present problems.

Quickfit-TL™ provides a tolerance of $+1/-1$ mm on drilling operation while ensuring that the final result is a perfectly precise and aligned joint. No other assembly fittings system can offer such tolerances and still maintain a perfect joint.

Assembly

1. Press the cam into face board



2a. Either push dowel into edge hole or...

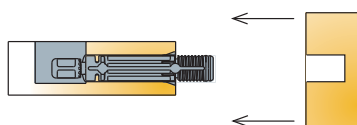

2b. Insert the dowel into side panel

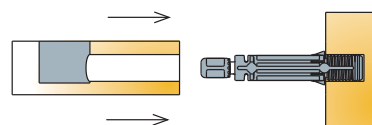

3. Assemble the panels

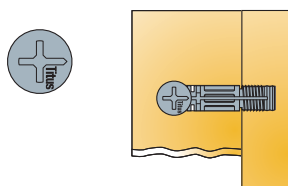

4. Tighten cam to lock dowel

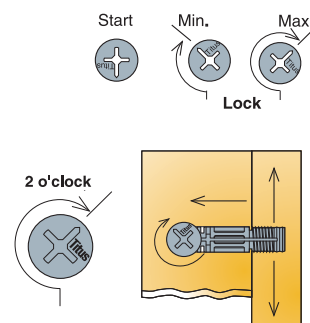

System 5

Cams and Dowels

Quickfit TL5

'Full Metal Jacket'

Quickfit TL5 with expanding steel sleeve is the new generation of Titus Quickfit TL dowels. It expands the Titus Quickfit toolless insertion technology to widely used $\text{\O}5\text{mm}$ dowel holes.

Toolless insertion for $\text{\O}5\text{mm}$ dowel holes

Unique to the market:

- Easy to push in
- Works without wooden dowels

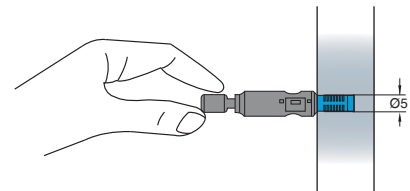

Expanding steel sleeve

Expanding steel sleeve assures high resistance to torsion and pull-out.

High drilling tolerances

Extended dowel head form works as a positive stop against the cam and provides tolerances of $\pm 1\text{mm}$ on drilling operation.

System 5

Cams and Dowels

Shape of dowel sleeve

- Acts as a positive stop when face inserted
- Ensures correct insertion depth

50% less time to assemble the cabinet with factory insertion

Quickfit TL5 dowel is inserted into the panel by simply pushing the head of the dowel into the edge hole until it engages with the cam. It remains in this position until the cam is rotated to lock the boards together.

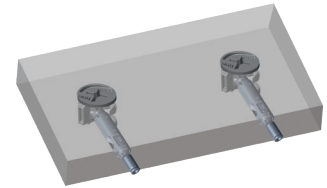

For maximum efficiency, the insertion process can be automated using the Titus proprietary Lama FastFit machine.

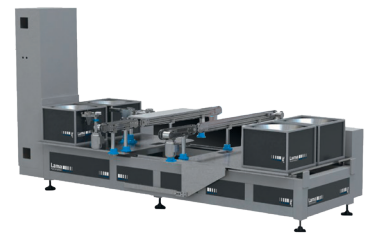

Functions with multiple wooden materials

- Functions with multiple materials: chipboard, MDF, solid wood
- Improved performance in low density boards
- Assures strong and reliable joint

System 5 Quickfit TL5 'Full Metal Jacket'

- Toolless insertion technology for Ø5mm dowel holes
- To be used with Cam5000 only
- Drilling tolerances of +/-1mm when edge or face inserted
- Expanding steel sleeve assures a strong joint, highly resistant to pull-out
- Functions in multiple wooden materials (chipboard, MDF, solid wood)

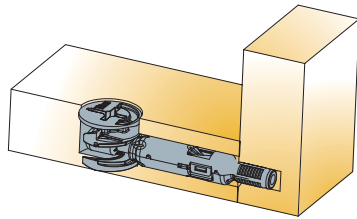

Technical and mounting details

Quickfit TL5

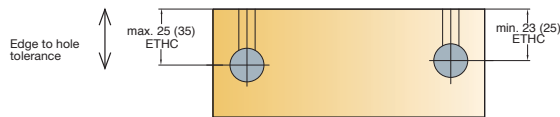
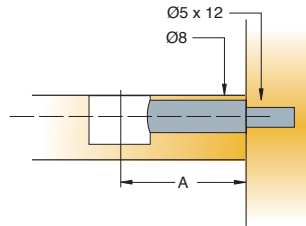

Tolerance range

Made of steel

A

Drilling distance (mm)

Item number

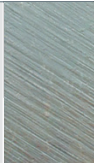

Zinc corrosion

24

009651 →

897

34

009652 →

897



To be used on Cam5000 only

System 5 Cams and Dowels Quickfit-TL Dowels

- Available in Ø5mm and Ø8mm for panel-to-panel applications
- Suitable for use with all Ø15mm Cam2000, Cam3000 and Cam5000 products
- 'Klix' locking feature provides a strong, vibration proof joint
- Highly tolerant in edge-inserted, TL4 also in face-inserted applications

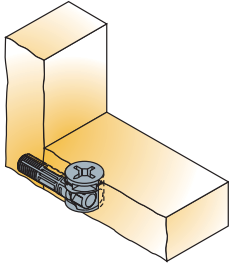

Technical and mounting details

| A | D2 | Item number | Black | Dark grey |
|---|----|-------------|---------------------|---|
| | | | Drilling depth (mm) | Drilling diameter for dowel thread (mm) |

Quickfit TL2

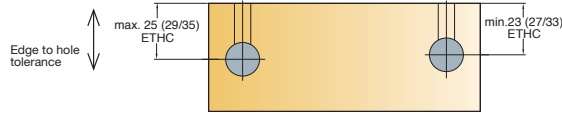
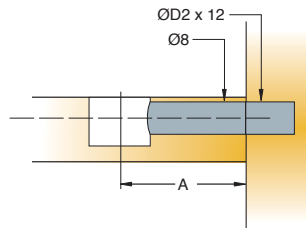

Tolerance range

Made of plastic and zinc

| | | | | |
|----|---|---------|--|------|
| 24 | 5 | 05453 → | | 880* |
| 34 | 5 | 05503 → | | 880* |
| 24 | 8 | 05441 → | | 880 |
| 28 | 8 | 05314 → | | 880* |
| 34 | 8 | 05474 → | | 880 |

Quickfit TL4

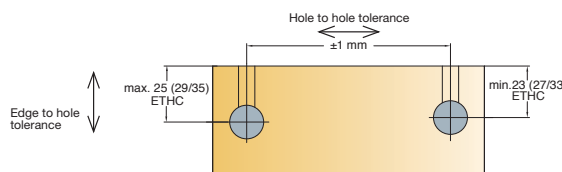
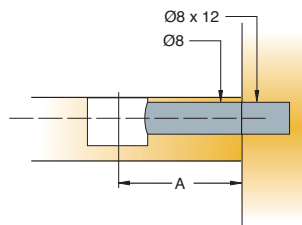

Tolerance range

Made of plastic and zinc

| | | | | |
|----|---|---------|--|------|
| 24 | 8 | 02144 → | | 835* |
|----|---|---------|--|------|

System 5 Cams and Dowels Quickfit-P2F Dowels

- The only product to enable standard panel drilling, connection of panel and hollow profile
- Available in Ø8mm for panel-to-hollow profile applications
- Suitable for use with all Ø15mm Cam2000, Cam3000 and Cam5000 products
- 'Klix' locking feature provides a strong, vibration proof joint

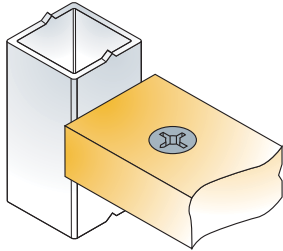

Technical and mounting details

Quickfit P2F

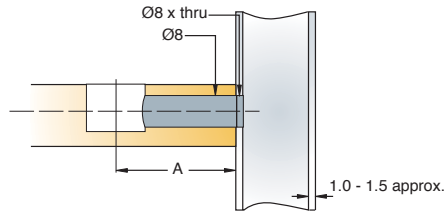
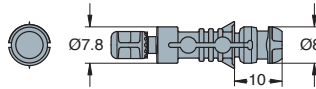

A

Drilling distance (mm)

Item number

Black

24

05414 →

835*

Made of plastic and zinc

System 5 Cams and Dowels Combi Dowel

- High quality zinc+steel dowel with greater resistance to torsion and pull-out
- Suitable for use with all Ø12mm and Ø15mm Cam2000, Cam3000 and Cam5000 products
- 'Klix' locking feature provides a strong, vibration proof joint
- Twinstart thread for faster and reliable insertion

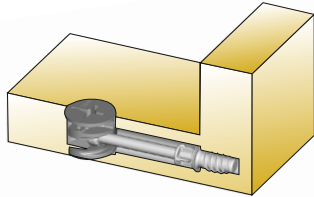

Technical and mounting details

Combi Dowel Ø5mm

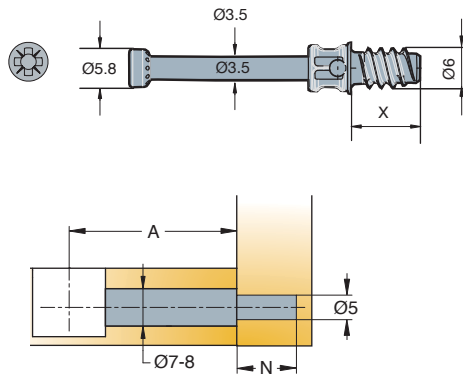

Made of steel and zinc

Combi Dowel M6

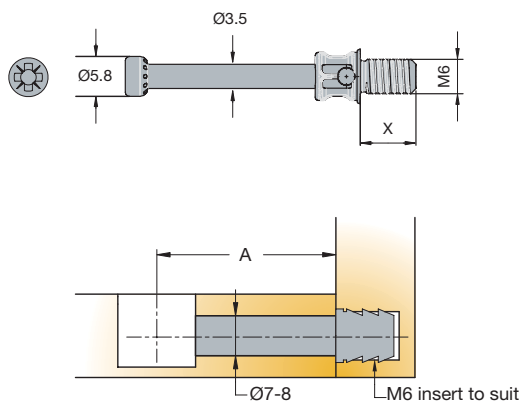

Made of steel and zinc

| A | N | X | Item number | Zinc |
|---|---------------------|--------------------|-------------|------|
| Drilling distance (mm) | Drilling depth (mm) | Thread length (mm) | | |
| 34 | 12 | 11 | 09435 → | 885 |
| 28 | 10 | 9.5 | 09588 → | 885 |
| 24 | 12 | 11 | 09443 → | 885* |
| 24 | 9 | 8.5 | 09583 → | 885* |
| • Phillips head option available on request | | | | |
| 34 | | 8 | 09592 → | 885 |
| 34 | | 10.5 | 09594 → | 885 |



Inserts
Made of zinc

→ see page 3.54







Inserts
Made of plastic

→ see page 3.55

System 5

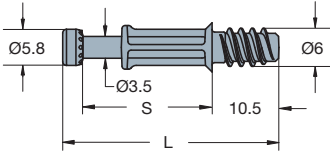
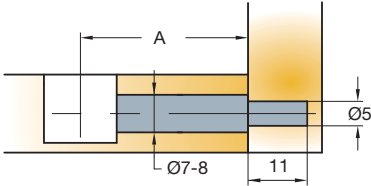
Cams and Dowels

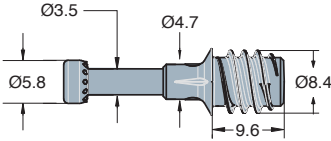
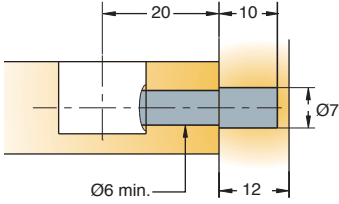
Zinc Dowel

| Technical and mounting details | | | | | | |
|--|---|-------------------|------------------------|-------------|---------|------|
| | S | L | A | | | |
| | Body length (mm) | Total length (mm) | Drilling distance (mm) | Item number | | |
| | | | | Zinc | | |
| Combi Dowel Ø5 Full Body    | PZ2 Head  | 20.6 | 34.5 | 24 | 09605 → | 885 |
| | | | 34 | 05534 → | 885 | |
| Made of steel and zinc | | | | | | |
| Combi Dowel Ø7    | Philips PH2 Head  | | | 20 | 09430 → | 885* |
| Made of steel and zinc | | | | | | |



Plastic inserts → see page 3.55

System 5 Cams and Dowels Double-ended Dowel

- Available in Ø7mm
- Suitable for use with all Ø12mm and Ø15mm Cam2000, Cam3000 and Cam5000 products
- No circlip for increased tolerance
- Available in a variety of lengths to suit most panel-to-panel applications

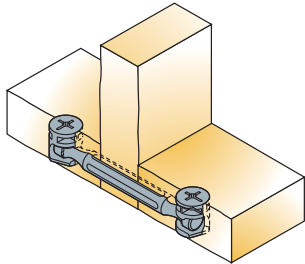

Technical and mounting details

Dowel without Circlip

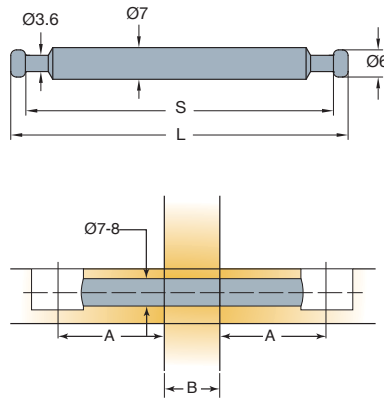

Made of steel

Dowel with Circlip

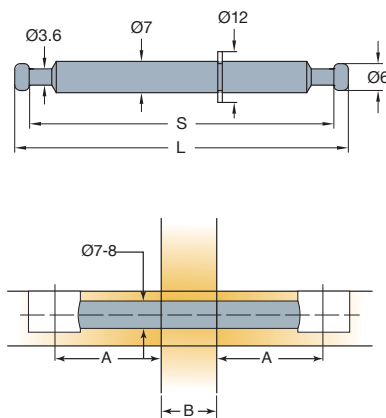

Made of steel and zinc

| S | L | A | B | Item number | Zinc plated |
|--------------------------|-------------------|------------------------|----------------------|-------------|-------------|
| Body length (mm) | Total length (mm) | Drilling distance (mm) | Panel thickness (mm) | | |
| 41 | 47.4 | 24 | ^0 | 05929 → | 883* |
| 61 | 67.4 | 34 | ^0 | 05757 → | 883* |
| 77 | 83.4 | 34 | 16 | 05858 → | 883* |
| 79 | 85.4 | 34 | 18 | 05859 → | 883* |
| 80 | 86.4 | 34 | 19 | 05753 → | 883* |
| 56 | 62.4 | 24 | 15 | 05592 → | 883* |
| 57 | 63.4 | 24 | 16 | 05857 → | 883* |
| 59 | 65.4 | 24 | 18 | 05380 → | 883* |
| 60 | 66.4 | 24 | 19 | 05778 → | 883* |
| ^B=0 → no panel required | | | | | |
| 77 | 83.4 | 34 | 16 | 05752 → | 883* |
| 79 | 85.4 | 34 | 18 | 05772 → | 883* |
| 80 | 86.4 | 34 | 19 | 05751 → | 883* |
| 57 | 63.4 | 24 | 16 | 05775 → | 883* |
| 60 | 66.4 | 24 | 19 | 05774 → | 883* |

System 5 Cams and Dowels Angled Dowels

- Suitable for applications requiring angled joints
- Suitable for use with all Ø12mm and Ø15mm Cam2000, Cam3000 and Cam5000 products
- Adjustable angle from 90° to 180°

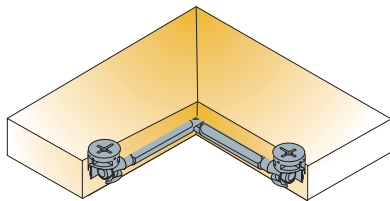

Technical and mounting details

Item number

Zinc plated

Angled Dowel

05860 →

883

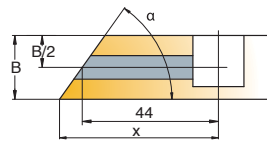
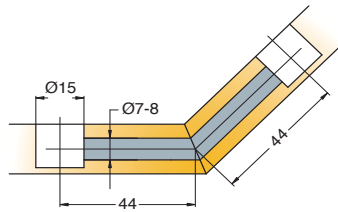

Distance x in mm

| α | 20° | 25° | 30° | 35° | 40° | 45° | 50° | 55° | 60° | 65° | 67,5° | 70° | 75° | 80° | 85° |
|-------------|------|------|------|------|------|------|------|------|------|------|-------|------|------|------|------|
| 13 | 61.9 | 57.9 | 55.3 | 53.5 | 51.7 | 50.5 | 49.5 | 48.6 | 47.8 | 47 | 46.7 | 46.4 | 45.7 | 45.1 | 44.6 |
| 15 | 64.6 | 60.1 | 57 | 54.7 | 52.9 | 51.5 | 50.3 | 49.3 | 48.3 | 47.5 | 47.1 | 46.7 | 46 | 45.3 | 44.7 |
| 16 | 66 | 61.2 | 57.9 | 55.4 | 53.5 | 52 | 50.7 | 49.6 | 48.6 | 47.7 | 47.3 | 46.9 | 46.1 | 45.4 | 44.7 |
| B 18 | 68.8 | 63.3 | 59.6 | 56.9 | 54.7 | 53 | 51.6 | 50.3 | 49.2 | 48.2 | 47.7 | 47.3 | 46.4 | 45.6 | 44.8 |
| 19 | 70.1 | 64.4 | 60.5 | 57.6 | 55.3 | 53.5 | 52 | 50.7 | 49.5 | 48.4 | 47.9 | 47.5 | 46.5 | 45.7 | 44.8 |
| 22 | 74.2 | 67.6 | 63.1 | 59.7 | 57.1 | 55 | 53.2 | 51.7 | 50.4 | 49.1 | 48.6 | 48 | 46.9 | 45.9 | 45 |
| 23 | 75.6 | 68.7 | 63.9 | 60.4 | 57.7 | 55.5 | 53.6 | 52.1 | 50.6 | 49.4 | 48.8 | 48.2 | 47.1 | 46 | 45 |

Made of steel

System 5

Cams and Dowels

Ø15mm Cam5000

- Improved central shape for highly resistant cam
- Suitable for use with steel Quickfit TL5 dowels and all other parallel neck dowels
- 'Klix' locking feature provides a strong, vibration proof joint
- Cam-retaining pips ensure that a cam is held in panel position prior to assembly

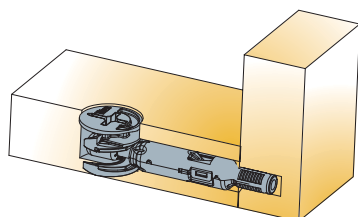

Technical and mounting details

| B | D | e | h | Item number | Zinc |
|----------------------|---------------------|-------------------------|-----------------|-------------|------|
| Panel thickness (mm) | Drilling depth (mm) | Drilling for dowel (mm) | Cam height (mm) | | |

Cam5000 Cross Drive

PZ2 Drive

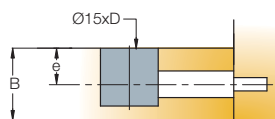
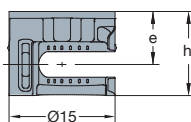

| | | | | | |
|-------|------|--------|------|----------|---------|
| 12/13 | 10.5 | 6 min. | 9.9 | 009695 → | 885.300 |
| 15/16 | 12.5 | 7.5-8 | 11.9 | 009690 → | 885.300 |

Made of zinc

Cam5000 Hexagonal Drive

Combined Drive with HEX

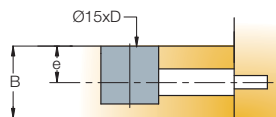
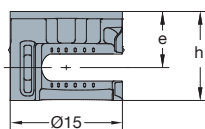

| | | | | | |
|-------|------|-------|------|----------|---------|
| 15/16 | 12.5 | 7.5-8 | 11.9 | 009699 → | 885.300 |
| 18/19 | 14 | 9-9.5 | 13.2 | 009692 → | 885.300 |

- Use standard cover caps with pin=Ø4mm
- Black available on request







Made of zinc

System 5

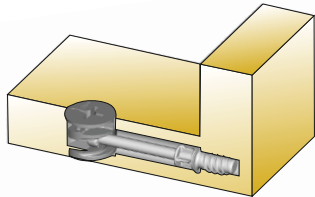
Cams and Dowels

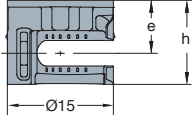
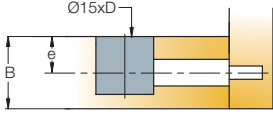
Ø15mm Cam3000

- Its optimised shape provides a more efficient cam profile with smooth tightening action and greater dowel pull-up
- Suitable for use with Combi dowels, forged steel dowels, Quickfit dowels and Quickfit TL5 dowels
- 'Klix' locking feature provides a strong, vibration proof joint
- Cam-retaining pips ensure that a cam is held in panel position prior to assembly

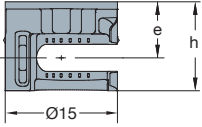
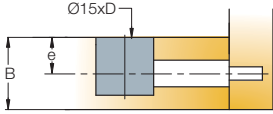
| Technical and mounting details | | B | D | e | h | Item number | Zinc | |
|---|--------------------------------|--|---------------------|-------------------------|-----------------|-------------|----------------|------|
| | | Panel thickness (mm) | Drilling depth (mm) | Drilling for dowel (mm) | Cam height (mm) | | | |
|  | Cam3000 Cross Drive | PZ2 Drive  | 12/13 | 10.5 | 6 min. | 9.9 | 09642 → | 885 |
| | | | 15/16 | 12.5 | 7.5-8 | 11.9 | 09490 → | 885* |
|    | | · Black available on request | | | | | | |
| Made of zinc | | | | | | | | |
|  | Cam3000 Hexagonal Drive | Combined Drive with HEX  | 15/16 | 12.5 | 7.5-8 | 11.9 | 09537 → | 885* |
| | | | 18/19 | 14 | 9-9.5 | 13.2 | 09536 → | 885* |
|    | | · Use standard cover caps with pin=Ø4mm · Black available on request | | | | | | |
| Made of zinc | | | | | | | | |

System 5 Cams and Dowels Ø15mm Cam3000 S

- Innovative design offers optimal performance with maximum cost effectiveness
- Suitable for use with Combi dowels, forged steel dowels and Quickfit dowels
- 'Klix' locking feature provides a strong, vibration proof joint
- Cam-retaining pips ensure that a cam is held in panel position prior to assembly

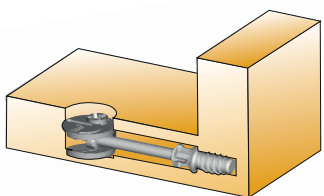

Technical and mounting details

Cam3000 S/15

PZ2 Drive 

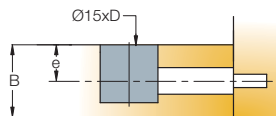
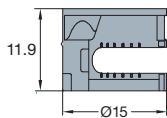

| B | D | e | | | |
|----------------------|---------------------|-------------------------|-------------|------|---------------|
| Panel thickness (mm) | Drilling depth (mm) | Drilling for dowel (mm) | Item number | Zinc | Zinc corrosil |
| 15/18 | 12.5 | 7.5-8 | 09491 → | 885* | 897* |

Made of zinc



Cover Caps
Made of plastic

→ see page 3.56

System 5 Cams and Dowels Ø15mm Cam2000

- Available in a variety of head, drive recess and board thickness versions to suit most applications
- Suitable for use with all Titus dowels
- 'Klix' locking feature provides a strong, vibration proof joint
- Linear cam profile results in smooth, easy cam rotation and dowel pull-up

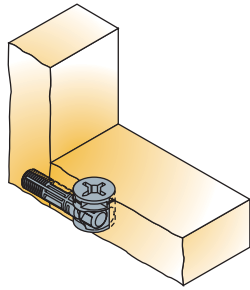

Technical and mounting details

Cam2000 Ø15



PH Drive 

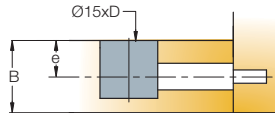

PZ Drive 

| B | D | e | Item number | Nickel | Zinc |
|--|---------------------|-------------------------|----------------------|--------|------|
| Panel thickness (mm) | Drilling depth (mm) | Drilling for dowel (mm) | | | |
| 12/13 | 10 min. | 6-6.5 | [^] 05587 → | 847* | 885* |
| 12/13 | 10.9 | 6-6.5 | 05653 → | 847* | 885* |
| 15/16 | 12.7 | 7.5-8 | 05644 → | 847* | 885 |
| 15/16 | 12.7 | 7.5-8 | 05654 → | 847* | 885 |
| 18/19 | 14 | 9-9.5 | 05656 → | 847* | 885 |
| 22/23 | 16 | 11-11.5 | 05657 → | 847* | 885 |
| 25/26 | 17.9 | 12.5-13 | 05676 → | 847* | 885 |
| 28/29 | 19.4 | 14-15.5 | 05678 → | 847* | 885 |
| ^Ultraflat - specially designed for thin panels (not compatible with TL dowels) · Other finishes available on request | | | | | |
| Made of zinc | | | | | |
| 12 | 10 min. | 6 | [^] 05586 → | 847* | 885* |
| 13 | 10.9 min. | 6.5 | 05652 → | 847* | 885* |
| 16 | 12.9 | 8 | 05658 → | 847* | 885* |
| 19 | 13 | 9.5 | 05659 → | 847* | 885* |
| 23 | 14.5 | 11.5 | 05675 → | 847* | 885* |
| 26 | 16.5 | 13 | 05677 → | 847* | 885* |
| 29 | 19.4 | 14.5 | 05679 → | 847* | 885* |
| ^Ultraflat - specially designed for thin panels (not compatible with TL dowels) · Other finishes available on request | | | | | |
| Made of zinc | | | | | |

Cam2000 Ø15 Headed

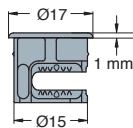

PH Drive 

PZ Drive 

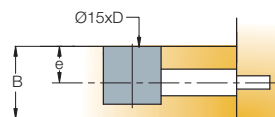

 Cover Caps for Ø15 Cams → see page 3.56
Made of plastic

System 5 Cams and Dowels Ø12mm Cam2000

- Suitable for all Titus screw-in dowels
- Available in a variety of head, drive recess and board thickness versions to suit most applications
- Particularly suited to drawer front attachment applications
- 'Klix' locking feature provides a strong, vibration proof joint
- Linear cam profile results in smooth, easy cam rotation and dowel pull-up

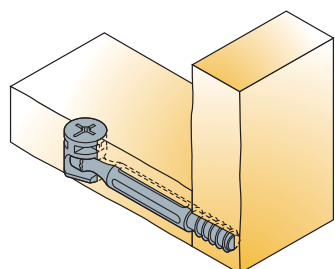

Technical and mounting details

| | B | D | e | | | | | |
|---|----------------------|---------------------|-------------------------|-------------|----------------------|---------------|------|---------------|
| | Panel thickness (mm) | Drilling depth (mm) | Drilling for dowel (mm) | Item number | Black painting plate | Nickel plated | Zinc | Corrosil zinc |
| Cam2000 Ø12 | 12/13 | 10 min. | 6-6.5 | 05575 → | 838* | 847* | 885* | 897* |
| | 15/16 | 12 | 7.5-8 | 05578 → | | | 885* | |
| | 18/19 | 13 min. | 9-9.5 | 05580 → | | | 885* | |
| <ul style="list-style-type: none"> • Other finishes available on request | | | | | | | | |
| Cam2000 Ø12 Headed | 12 | 9.5 min. | 5.25 | 05574 → | 838* | 847* | 885* | 897* |
| | 12 | 10 min | 6 | 05576 → | | | 885* | |
| | 16 | 12.5 | 8 | 05579 → | | | 885* | |
| <ul style="list-style-type: none"> • Other finishes available on request | | | | | | | | |

Cam2000 Ø12

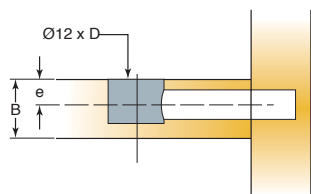
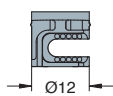

Made of zinc

Cam2000 Ø12 Headed

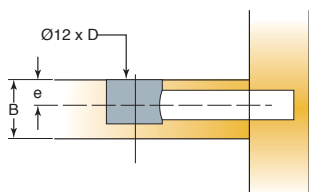
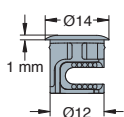

Made of zinc



Cover Caps for Ø12 Cams → see page 3.56
Made of plastic

System 6

Quickfit-Expando Connectors

System Features

A face boring connector family for 32mm system drilling with full range of panel and application variants for all cabinet manufacturing applications:

- Minimum drilling requirements
- Linear cam design for constant tightening loads when driving
- Angledrive feature on cam for maximum driving comfort
- Interchangeable pins for wood, plastic and steel applications
- Pins with twinstart drive for fast insertion
- Interchangeable Quickfit pin fastenings available
- Toolless fastening capable versions
- Back-to-back fastenings for common vertical panel fixing of shelves

System 6 consists of a range of 20mm and 25mm diameter housings, Quickfit™ and conventional dowels, end dowels and double ended dowels.

Housings are made from high grade plastic or zinc, with zinc cams.

Wedgefix-6 connector is a special fastener without cam, simply to snap onto a pre-inserted dowel.

Applications

Titus System 6 is ideal for use in high volume production of case goods, closet and garage storage systems. As no edge boring is required,

it is an excellent choice for manufacturing environments with limited drilling capacity.

Side-entry Drop-on

Side-entry insertion of shelf panel: from the side or from the top.

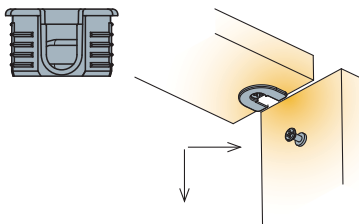

Drop-on insertion of shelf panel: only from the top.

Using drop-on connections allows for one-man installation.

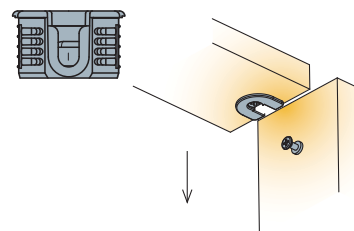

Angledrive feature

The angledrive feature on the cam allows for the angled position of the screwdriver with the locking action creating a tight and secure joint.

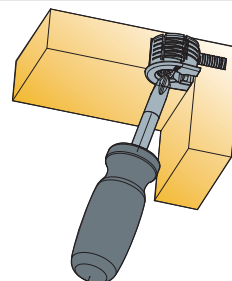

System 6 Quickfit-Expando Connectors

System Features

Outrigger/
Non-outrigger

Outrigger

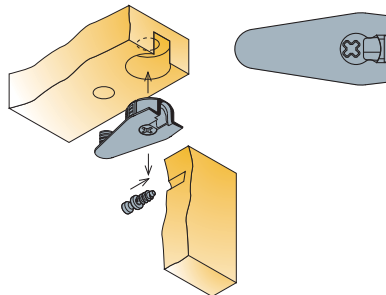

Non-outrigger

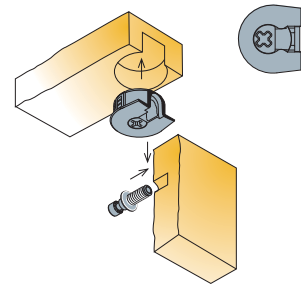

Expando function

Expanding housings and dowels provide a tight joint.

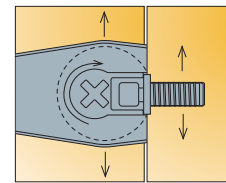
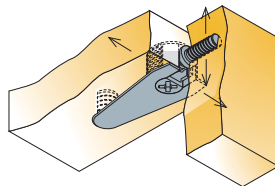

Assembly

1. Press the housing into face board

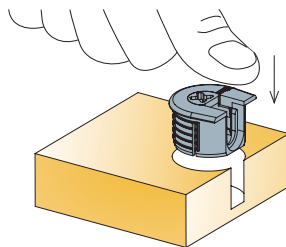

2. Press the dowel into side panel

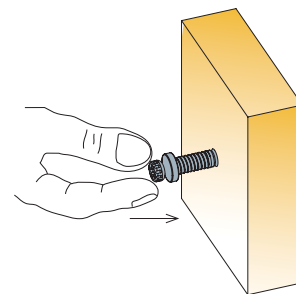

3. Assemble the panels

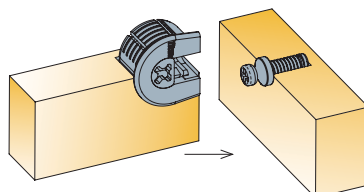



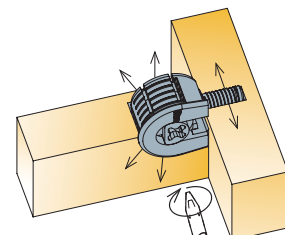



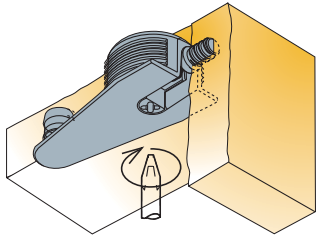

4. Tighten the joint

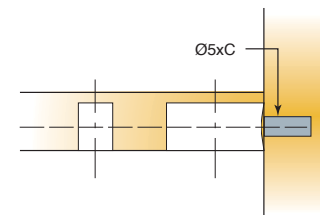

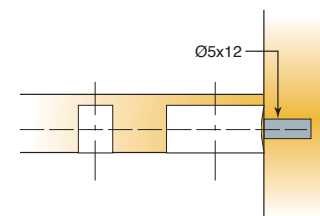
System 6 Quickfit-Expando Dowels

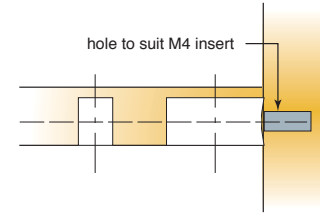
- Available in various Ø3mm and/or Ø5mm thread forms for screw-in, knock-in and/or 'spiked' hole applications
- Suitable for applications with all Titus Ø20mm and/or Ø25mm Expando-6 housings
- 'Klix' locking feature provides a strong, vibration proof connection
- Dowels feature an integral skirt which acts as a positive stop during insertion

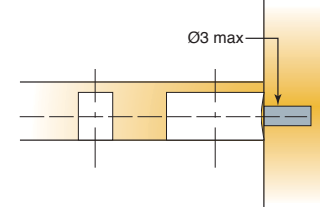
|  | | | C | | | |
|--|--|--|---|-------------|------|-------------|
| | | | Drilling diameter for dowel thread (mm) | Item number | Zinc | Zinc plated |
| Technical and mounting details | | | | | | |
| Dowel Ø5    | | | 9 | 06401 → | 885* | |
| | | | 8 | 06402 → | 885 | 883* |
| | | | 11.5 | 06406 → | 885 | 883 |
| Made of zinc or steel | | | | | | |
| Dowel Ø5 x 11 Knock-in    | | | | 06403 → | 885* | |
| Made of zinc | | | | | | |
| Dowel M4 x 7    | | | | 06405 → | | 883* |
| Made of steel | | | | | | |
| Dowel Ø3 x 11.5    | | | | 06495 → | | 883* |
| Made of steel | | | | | | |

 Plastic inserts → see page 3.54

System 6 Quickfit-Expando Double-ended Dowels

- For 16mm, 18mm and 19mm board
- Suitable for applications with all Titus Ø20mm and/or Ø25mm Expando-6 housings
- 'Klix' locking feature provides a strong, vibration proof connection

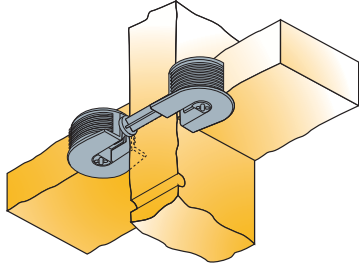

Technical and mounting details

Double-ended Dowel

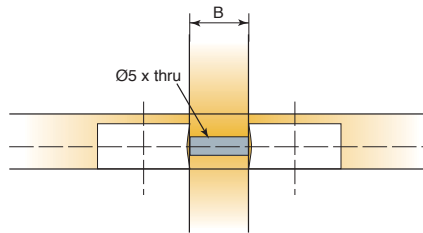
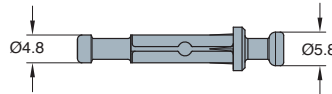

| B | Panel thickness (mm) | Item number | Zinc |
|---|----------------------|-------------|------|
| | 16 | 06414 → | 885 |
| | 18 | 06413 → | 885* |
| | 19 | 06416 → | 885* |

Made of zinc

System 6

Quickfit-Expando

20mm Expanding Housing

Non-outrigger

- Available in 15mm/16mm and 18mm/19mm versions for drop-on and/or side-entry applications
- Available in all-metal or plastic/metal options
- 'Klix' locking feature provides a strong vibration proof connection
- Compatible with all screw-in and Quickfit-6 dowels

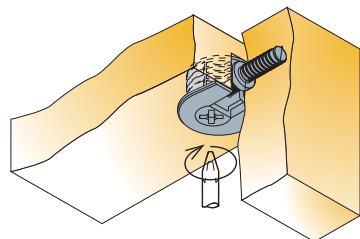

Technical and mounting details

| | | e | B | D | | | | | |
|-----------------|--|---------------------------------------|----------------------|---------------------|-------------|--------------------|---------------|----------------|---------------|
| | | Drilling for dowel (mm) | Panel thickness (mm) | Drilling depth (mm) | Item number | Dark brown plastic | Nickel plated | Silver plastic | White plastic |
| Side-entry | | 8 | 15/16 | 12.5 | 06451 → | | 847* | | |
| | | 9.5 | 18/19 | 14 | 06453 → | | 847* | | |
| Made of zinc | | | | | | | | | |
| Side-entry | | 8 | 15/16 | 12.5 | 06435 → | 831* | | 861* | 877 |
| | | 9.5 | 18/19 | 14 | 06437 → | 831* | | 861* | 877* |
| Made of plastic | | • Other finishes available on request | | | | | | | |
| Drop-on | | 8 | 15/16 | 12.5 | 06447 → | | 847* | | |
| | | 9.5 | 18/19 | 14 | 06449 → | | 847* | | |
| Made of zinc | | | | | | | | | |
| Drop-on | | 8 | 15/16 | 12.5 | 06431 → | 831* | | 861* | 877* |
| | | 9.5 | 18/19 | 14 | 06433 → | 831* | | 861* | 877* |
| Made of plastic | | • Other finishes available on request | | | | | | | |

System 6

Quickfit-Expando

20mm Expando Housing

Outrigger

- Available in 15mm/16mm and 18mm/19mm versions for drop-on and/or side-entry applications
- Available in all-metal or plastic/metal options
- 'Klix' locking feature provides a strong vibration proof connection
- Compatible with all screw-in and Quickfit-6 dowels

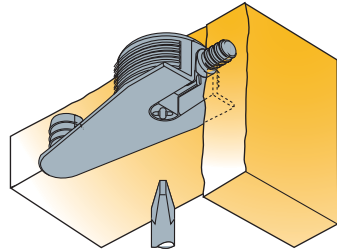

Technical and mounting details

| e | B | D | Item number | Finish | | | |
|-------------------------|----------------------|---------------------|-------------|--------------------|---------------|---------------|---------------|
| | | | | Dark brown plastic | Black plastic | Nickel plated | White plastic |
| Drilling for dowel (mm) | Panel thickness (mm) | Drilling depth (mm) | | | | | |

Side-entry

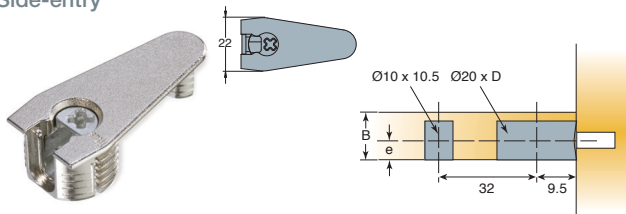

Made of zinc

| | | | | | | | |
|-----|-------|------|---------|--|--|------|--|
| 8 | 15/16 | 12.5 | 06459 → | | | 847* | |
| 9.5 | 18/19 | 14 | 06461 → | | | 847* | |

Side-entry

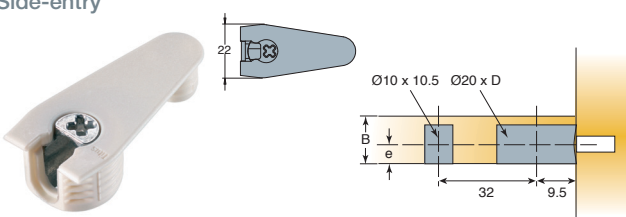

Made of plastic

| | | | | | | | |
|-----|-------|------|---------|------|------|--|------|
| 8 | 15/16 | 12.5 | 06443 → | 831* | 835* | | 877 |
| 9.5 | 18/19 | 14 | 06445 → | | 835* | | 877* |

· Other finishes available on request

Drop-on

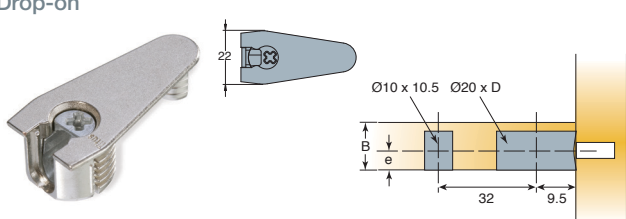

Made of zinc

| | | | | | | | |
|-----|-------|------|---------|--|--|------|--|
| 8 | 15/16 | 12.5 | 06455 → | | | 847 | |
| 9.5 | 18/19 | 14 | 06457 → | | | 847* | |

Drop-on

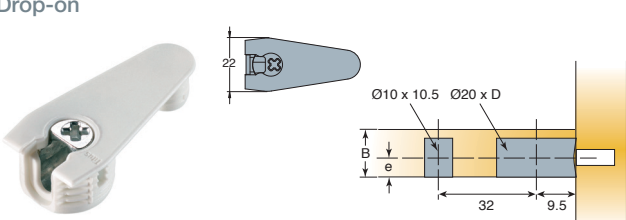

Made of plastic

| | | | | | | | |
|-----|-------|------|---------|------|------|--|------|
| 8 | 15/16 | 12.5 | 06439 → | 831* | 835* | | 877 |
| 9.5 | 18/19 | 14 | 06441 → | 831* | 835* | | 877* |

· Other finishes available on request

System 6

Quickfit-Expando

Expando Wedgefix

Housing (No Inner Cam)

- Available in 12mm, 15mm/16mm and/or 18mm/19mm versions for Quickfit-6 and/or standard dowel applications
- Available in a variety of plastic colours
- Wedgefix-6 housing allows easy customer hand assembly or factory automated insertion
- When used with Quickfit-6 dowels this provides a true toolless fastening system

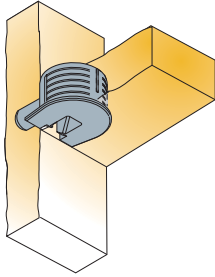

Technical and mounting details

For Use with Screw-in Dowels

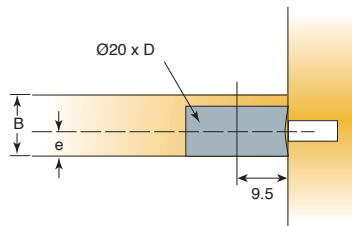
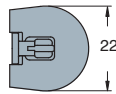

Made of plastic

For Use with Quickfit Dowels

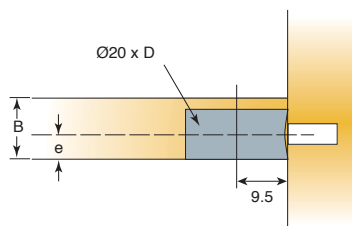
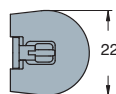

Made of plastic

| e | B | D | Item number | Colour | | | |
|---------------------------------------|----------------------|---------------------|-------------|--------|-------|------------|--------|
| | | | | White | Black | Dark brown | Silver |
| Drilling for dowel (mm) | Panel thickness (mm) | Drilling depth (mm) | | | | | |
| 6 | 12 | 10 | 06470 → | 877* | | | 861* |
| 8 | 15/16 | 12.5 | 06473 → | 877 | 835* | 831* | 861* |
| 9.5 | 18/19 | 14 | 06465 → | 877* | 835* | 831* | 861* |
| 11 | 22 | 16 | 06464 → | | | | 861* |
| • Other finishes available on request | | | | | | | |
| 8 | 15/16 | 12.5 | 06471 → | 877* | 835* | 831* | 861* |
| 9.5 | 18/19 | 14 | 06472 → | 877* | 835* | 831* | 861* |
| • Other finishes available on request | | | | | | | |

System 6

20mm Knock-in Housing

Non-outrigger

- Available in 15mm/16mm and 18mm/19mm versions for drop-on and/or side-entry applications
- Available in all-metal or plastic/metal options
- 'Klix' locking feature provides a strong vibration proof connection
- Compatible with all screw-in and Quickfit-6 dowels

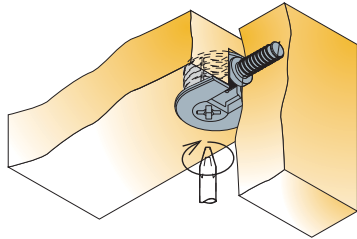

Technical and mounting details

Side-entry

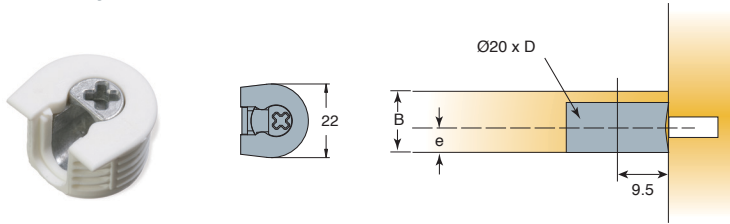

Made of plastic

Drop-on

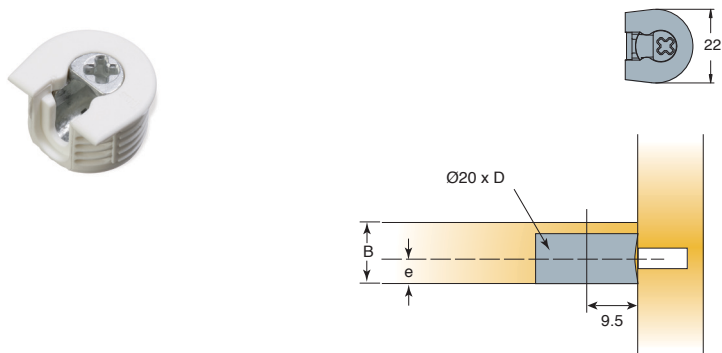

Made of plastic







| e | B | D | Item number | | |
|-------------------------|----------------------|---------------------|-------------|---------------|---------------|
| | | | | Black plastic | White plastic |
| Drilling for dowel (mm) | Panel thickness (mm) | Drilling depth (mm) | | | |
| 8 | 15/16 | 12.5 | 06381 → | 835 | 877 |
| 9.5 | 18/19 | 14 | 06385 → | 835* | 877 |
| 8 | 15/16 | 12.5 | 06383 → | 835* | 877 |
| 9.5 | 18/19 | 14 | 06387 → | 835* | 877 |

System 7

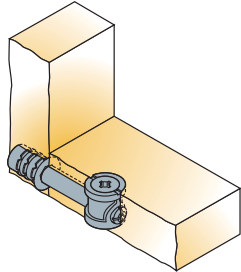
High Strength Connectors

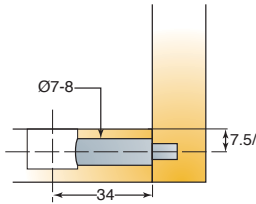
Contract Fix™ System

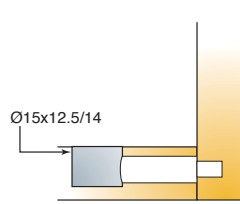
- High performance fastener
- Thread design gives repeatability
- Multi-drive recess
- Higher than average pull-up

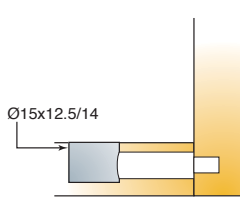
|  <p>Technical and mounting details</p> | Item number | Zinc plated | Zinc |
|---|-------------|-------------|------|
| <p>M6 Dowel 7x34</p>   <p>Made of steel</p> | 05971 → | 883 | |
| <p>Housing Cylinder 15x12</p>   <p>Made of zinc</p> | 05960 → | | 885 |
| <p>Grub Screw</p>   <p>Made of zinc</p> | 05917 → | | 885 |









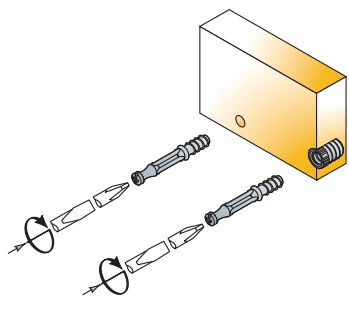

Inserts
Made of zinc

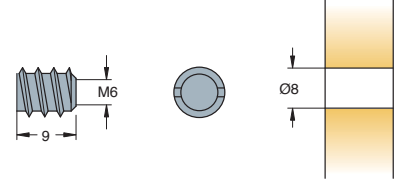
→ see page 3.54

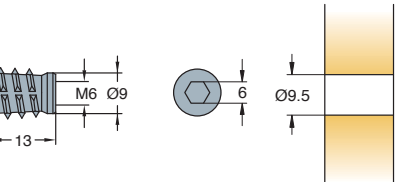
Accessories for Connectors Inserts

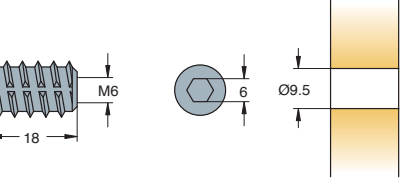
- Available in both zinc and plastic for use in various applications
- Suitable for use with various threaded dowels
- Suitable for use with various panel thicknesses
- Knock-in and screw-in versions available

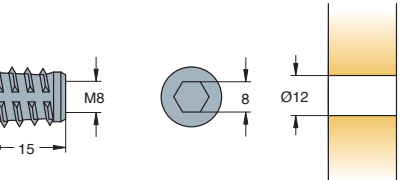
|  <p>Technical and mounting details</p> | Item number | Raw |
|---|-------------|------|
| <p>Ø8 x 9</p>   <p>Made of zinc</p> | 408.3166 → | 600* |
| <p>Ø9 x 13</p>   <p>Made of zinc</p> | 408.3391 → | 600 |
| <p>Ø9.5 x 18</p>   <p>Made of zinc</p> | 408.3423 → | 600* |
| <p>Ø12 x 15</p>   <p>Made of zinc</p> | 408.3424 → | 600* |





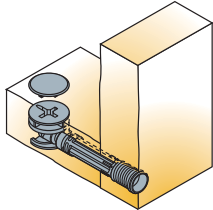

Accessories for Connectors Inserts

| | | C | | | |
|--|--|---|-------------|---------------|---------|
| | | Drilling length for insert (mm) | Item number | Natural white | Natural |
| Technical and mounting details | | | | | |
| Ø10 x 13/M6 Nut  |  275-4035 | 13 | 275.4035 → | 200* | |
| |  275-4058 | 11 | 275.4058 → | 200* | |
| | |  | | | |
| Made of plastic | | | | | |
| Ø8 x 10/M4 Nut  |  | | 276.4036 → | 200* | |
| | |  | | | |
| Made of plastic | | | | | |
| Euro Thread  |  Euro thread 5 | | 02182 → | | 346* |
| | |  | | | |
| Made of plastic | | | | | |

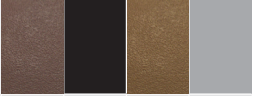
Accessories for Connectors Cover Caps

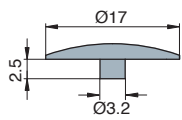
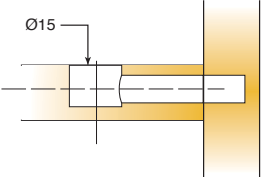
- Available in a variety of colours
- Suitable for use with both pozi and hex cam drive features
- Suitable for use with various diameter cams
- Both domed and flat versions available

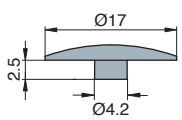
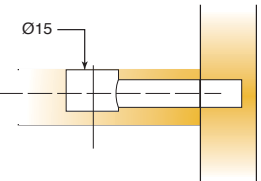

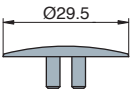
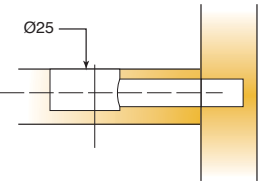
| | | | |  | | | |
|---|---|---------------------|-------------|---|-------|-------------|------------|
| | | Inner diameter (mm) | Item number | Dark brown | Black | Light brown | Light grey |
| <p>Technical and mounting details</p> | | | | | | | |
| <p>Cover Cap Ø17</p>  |  <p>PZ2</p>  <p>Made of plastic</p> | 3.2 | 277.4355 → | 370 | 390 | 330* | 380 |
| <ul style="list-style-type: none"> · Other finishes available on request · Suitable for cams with Pozi 2 recess | | | | | | | |
| <p>Cover Cap Ø17</p>  |  <p>Hex</p>  <p>Made of plastic</p> | 4.2 | 277.4225 → | 370* | 390* | 330* | 380* |
| <ul style="list-style-type: none"> · Other finishes available on request · Suitable for cams with Hex recess | | | | | | | |
| <p>Cover Cap Ø29.5</p>  |   <p>Made of plastic</p> | | 275.4034 → | 370* | 390* | 330* | 380* |
| <ul style="list-style-type: none"> · Other finishes available on request | | | | | | | |

Adjustable Cabinet Legs

Leg Top Fixes

- Lip provides additional support to end panel and gives extra strength
- Rivet fix design gives quick fastening of socket
- Choice of knock-in dowel or screw-in sockets
- Invert second clip for corner plinth fixing

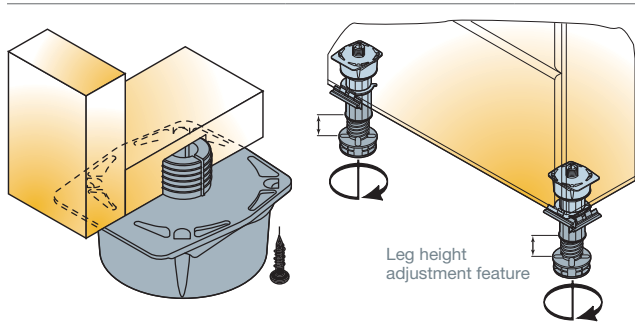

Leg Tops

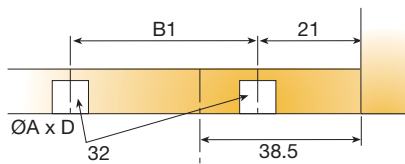

Made of plastic

Rivet Fix Leg Top

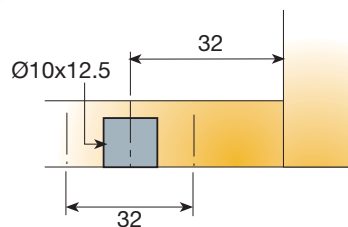
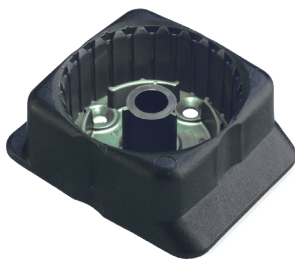

Made of plastic

| Description | A Drilling diameter (mm) | D Drilling depth (mm) | B1 Drilling distance (mm) | Item number | Black |
|----------------------------|-----------------------------|--------------------------|------------------------------|-------------|-------|
| With lip Knock-in 2-pin | 10/3 | 12.5/6 | 64x64 | 02669 → | 835 |
| With lip Screw-in | 3 | 6 | 64x64 | 02671 → | 835 |
| With lip Knock-in 4-pin | 10 | 12.5 | 64x64 | 02672 → | 835 |
| Without lip Knock-in 2-pin | 10/3 | 12.5/6 | 64x64 | 02711 → | 835 |
| Without lip Screw-in | 3 | 6 | 64x64 | 02712 → | 835 |
| Without lip Knock-in 4-pin | 10 | 12.5 | 64x64 | 02713 → | 835 |
| Rivet Fix Leg Top | 10 | 12.5 | | 02663 → | 835 |

Adjustable Cabinet Legs

Adjustable Leg, Extension and Foot

- Legs are supplied assembled at a pre-set height
- Wide adjustment range to fit all common plinth heights
- Jacking point adjustment feature
- Simple push-on socket design
- Telescopic leg offers unparalleled adjustment

|  <p>Leg height adjustment feature</p> | B1 | H | Item number | Black |
|--|--|---------|-------------|-------|
| <p>Adjustable Leg</p>  <p>02648</p> <p>Made of plastic</p> | 24 | 60-90 | 02570 → | 835 |
| | 24 | 92-150 | 02648 → | 835 |
| | <ul style="list-style-type: none"> · To be used with screw-in plinth clip 02634 → see page 3.60 | | | |
| <p>Adjustable Leg, Telescopic</p>  <p>Height adjustment from 85mm to 165mm as shown</p> <p>Made of plastic</p> | 38 | 85-165 | 02641 → | 835 |
| | <ul style="list-style-type: none"> · To be used with screw-in plinth clip 02500 → see page 3.60 | | | |
| <p>Adjustable Leg, with Foot</p>  <p>Made of plastic</p> | 38 | 92-150 | 02699 → | 835 |
| | 38 | 110-170 | 02645 → | 835 |
| | 38 | 125-185 | 02706 → | 835 |
| | <ul style="list-style-type: none"> · To be used with screw-in plinth clip 02710 or knock-in plinth clip 02578 → see page 3.60 | | | |

Adjustable Cabinet Legs

Adjustable Leg, Extension and Foot

- Leg extension for use with all adjustable legs
- Fixed foot allows for common drilling distance (B1) of all legs

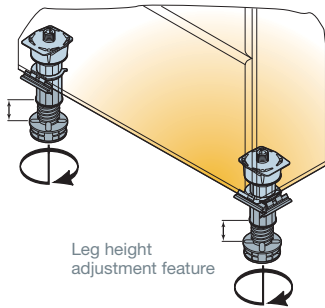

Leg Extension

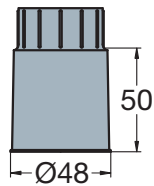

Made of plastic

Fixed Foot

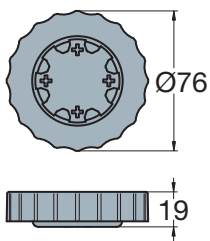

Made of plastic

Item number

Black

02571 →

835







02569 →

835

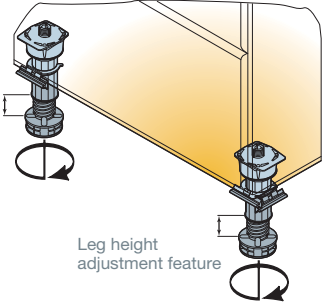

Adjustable Cabinet Legs

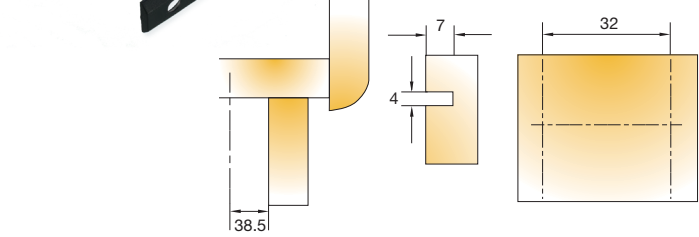
Plinth Clips

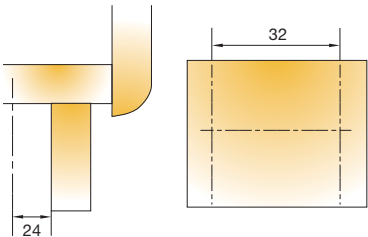
- Spring design eliminates the need for drilling and fits into any position on plinth
- The screw-in version can sit in variable plinth positions
- When taking plinth around the corner, the fitting is reversible

|  <p>Leg height adjustment feature</p> | B1 | | | Black |
|--|------------------------|---|-------------|-------|
| Plinth Clip | Drilling distance (mm) | Description | Item number | Black |
|  | 38 | Screw-in Plinth Clip for telescopic leg | 02500 → | 835 |
|  | 38 | Knock-in Plinth Clip | 02578 → | 835 |
|  | 38 | Screw-in Plinth Clip | 02710 → | 835 |
|  <p>Made of plastic</p> | | | | |
| Plinth Clip | 24 | Screw-in Plinth Clip | 02634 → | 835 |
|   <p>Made of plastic</p> | | | | |

Decorative Legs for Furniture

| | Finish | Adjustment (mm) | Length (mm) | Item number |
|--|-----------------|-----------------|-------------|------------------|
| Tiffany Leg Aluminium Ø35mm  <p>Made of aluminium</p> | Brushed Grey | 20 | 100 | 606.8D03.907.100 |
| | Brushed Grey | 20 | 125 | 606.8D03.907.125 |
| | Brushed Grey | 20 | 150 | 606.8D03.907.150 |
| Stainless Steel Leg Ø50mm  <p>Made of stainless steel</p> | Stainless Steel | 30 | 150 | 606.8D03.530.150 |
| Polished Chrome Leg Ø75mm  <p>Made of steel</p> | Polished Chrome | 30 | 870 | 606.8D05.452.707 |

Decorative Legs for Tables, Sofas and Beds

| | Finish | Length (mm) | Adjustment (mm) | Item number |
|---|--------------------|-------------|-----------------|------------------|
| Table Leg Ø60mm  | Brushed Nickel | 710 | 30 | 606.8D05.454.703 |
| | Polished Chrome | 710 | 30 | 606.8D05.454.707 |
| Made of steel | | | | |
| Square Sofa Leg 32 x 32mm  | Anodised Aluminium | 150 | N/A | 606.8D03.807.150 |
| Made of aluminium | | | | |

Fastmount® Panel Mounting

Fastmount Panel Mounting Systems

Perfect Panel Mounting

The secret to Fastmount™ is the unique set of design registered interchangeable clips ideal for secure fastening. With Fastmount, panels can be easily removed and refitted in any sequence, time after time.

Combining speed, versatility and accuracy, the Fastmount system enables designers, installers and contractors to re-think the paneling process.

Fastmount is designed to perform on sea, land and in the air. Applications of use are only limited by your imagination and common sense.

Benefits

- No visible fixings
- Eliminates panel damage – install panels during final build stages
- Variety of mounting options – self-tapping, glue and screw fix
- Allows for panel flex and expansion
- Provides cavities for services and enhanced acoustics

Applications

- Ceilings, walls, feature panels and upholstery
- Access, inspection and ventilation panels
- Interior and selected exterior applications
- Upholstered, painted, prefinished and composite panels
- Mounts into a wide variety of substrates e.g. GRP, composite, honeycomb
- New build, re-fit and upgrades

Clip Selection Guide

| SUBSTRATE TYPE | PANEL TYPE | | | | | | |
|-----------------------------|---|---|---|---|--|----------------------|-----------------|
| | Plywood | MDF | Particle Board | Acoustic Panel | Honeycomb | Fibrous Cement Board | Exterior Panels |
| Steel frames eg. Rhondo | PC-SF1 + PC-M1A PC-SF1 + PC-M2H PC-SF1 + PC-SM2 PC-SF1 + PC-SM2H | PC-SF1 + PC-M1A PC-SF1 + PC-SM2H | PC-SF1 + PC-M1A PC-SF1 + PC-SM2H + Glue Thread | PC-SF1 + PC-SM2 | PC-SF1 + PC-SM2 | N/A | N/A |
| Timber battens or frames | PC-F1A + PC-VM1 PC-F1A + PC-M2H PC-F1A + PC-SM2H | PC-F1A + PC-VM1 PC-F1A + PC-M2H | PC-F1A + PC-VM1 PC-F1A + PC-M2H | LP-F8 + LP-SM8 | LP-F8 + LP-SM8 | N/A | N/A |
| Concrete + timber batten | PC-F1A + PC-M2H PC-F1A + PC-SM2 PC-F1A + PC-SM2H | PC-F1A + PC-M2H PC-F1A + PC-SM2 PC-F1A + PC-SM2H | PC-F1A + PC-M2H PC-F1A + PC-SM2 PC-F1A + PC-SM2H | Must use Timber Batten + LP-F8 + LP-SM8 | Must use Timber Batten + LP-F8 + LP-SM88 | N/A | N/A |
| Drywall eg. Gib Board | LP-DF8 + LP-M8 LP-DF8 + LP-SM8 | LP-DF8 + LP-M8 LP-DF8 + LP-SM8 | LP-DF8 + LP-M8 LP-DF8 + LP-SM8 | LP-DF8 + LP-SM8 with HMA (hot glue) | LP-DF8 + LP-SM8 with epoxy glue | N/A | N/A |
| Plywood, MDF | PC-F1A + PC-M1A PC-F1A + PC-M2H PC-F1A + PC-SM2 PC-F1A + PC-SM2H | PC-F1A + PC-M1A PC-F1A + PC-M2H PC-F1A + PC-SM2 PC-F1A + PC-SM2H | PC-F1A + PC-M1A PC-F1A + PC-M2H PC-F1A + PC-SM2 PC-F1A + PC-SM2H | LP-F8 + LP-SM8 | LP-F8 + LP-SM8 with epoxy glue | | |

Fastmount Panel Mounting Systems

Standard Profile Range





- Panels can easily be removed and refitted in any sequence time after time
- Available in self-tapping installation
- A range of standard clips designed for adhesive fix, heavy duty, high shear strength and variable gap requirements

| | Mounting | Item number | White | Black |
|--|----------|-----------------------|-------|-------|
| PC-01 Self-tapping Clip Set  | TapFast | 606.8F20.122 → | 201 | |
| Standard self-tapping system suitable for most applications, using PC-F1A and PC-M1A. Fit with CT-03 and CT-10. | | | | |
| PC-M1B Standard Self-tapping Male Clip  | TapFast | 606.8F20.222 → | 201 | |
| Screws into 10mm hole drilled with CT-01 or CT-09. Fits into PC-F1A, PC-SF1, PC-RF1, PC-AF1. Install with CT-10 (CT-04 can also be used). | | | | |
| PC-M2H Self-tapping Heavy Duty Male Clip  | TapFast | 606.8F20.222 → | | 402 |
| Fits into PC-F1A, PC-SF1, PC-RF1, and PC-AF1. Mounts into 10mm hole CT-01 and CT-09. Minimum panel thickness 9mm. Install with CT-10. | | | | |
| PC-VM1 Vario Self-tapping Male Clip  | TapFast | 606.8F20.242 → | 201 | |
| Variable gap, high shear strength self-tapping male clip. Clips into PC-F1A, PC-SF1, PC-RF1, and PC-AF1. Mounts into 10mm hole CT-01 and CT-09. Install with CT-10. Minimum panel thickness 9mm. | | | | |
| PC-VMX Vario Self-tapping Extra Heavy Duty Male Clip, 15kg  | TapFast | 606.8F20.244 → | | 201 |
| Male self-tapping clip with variable gap and high shear strength. Mounts into PC-F1A, PC-SF1, PC-RF1, PC-AF1. Extra heavy duty clip with 15 kg pull-out load. Minimum panel thickness 9mm. Screws into 10mm hole with CT-10. | | | | |

Fastmount Panel Mounting Systems

Standard Profile Range

- Panels can easily be removed and refitted in any sequence time after time
- Available in self-tapping installation
- A range of standard clips designed for adhesive fix, heavy duty, high shear strength and variable gap requirements

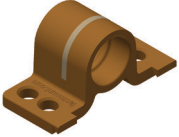
| | Mounting | Item number | White | Black | Brown |
|--|----------|-----------------------|-------|-------|-------|
| <p>PC-SM2 Standard Surface Mount Male Clip</p>  | Surface | 606.8F20.222 → | 801 | | |
| Adhesive fix super-groove base. Fits into PC-F1A, PC-SF1, PC-RF1 and PC-AF1. | | | | | |
| <p>PC-SM2H Surface Mount Heavy Duty Male Clip, 10kg</p>  | Surface | 606.8F20.224 → | | 802 | |
| Male surface mount heavy duty clip with super groove base for increased loading. Mounts into PC-F1A, PC-SF1, PC-RF1 and PC-AF1. 10kg pull-out load per clip. Epoxy glue fix. No special tools required for installation. | | | | | |
| <p>PC-F1A Standard Self-tapping Female Clip</p>  | TapFast | 606.8F20.322 → | 201 | | |
| Mounts into 16.8mm hole drill with CT-07, CT-13. Compatible with male clips, PC-M1A, PC-M2H, PC-SM2 and PC-VM1. Install with CT-03. | | | | | |
| <p>PC-SF1 Standard Surface Mount Female Clip</p>  | Surface | 606.8F20.322 → | 101 | | |
| Screw fix. See product sheet for details. Compatible with PC-M1A, PC-M2H, PC-SM2 and PC-VM1. | | | | | |
| <p>PC-RF1-B Standard Side Mount Female Clip</p>  | Side | 606.8F20.322 → | | | 143 |
| Screw fixed to side of decks heads (use CT-18 install jig), for ceiling application. Suitable for other applications such as floor panels and cabinets. Compatible with male clips, PC-M1A, PC-M2H, PC-SM2 and PC-VM1. | | | | | |



Fastmount Panel Mounting Systems

Standard Profile Range

| | Mounting | Item number | White |
|--|----------|-----------------------|-------|
| PC-AF1 Standard Female Auto Fit Clip  | Auto Fit | 606.8F20.322 → | 121 |
| Female push fit clip suitable for application requiring lateral adjustment. Fits all standard male clips: PC-M1A, PC-M2H, PC-SM2, PC-SM2H, and PC-VM1. | | | |





Standard Profile Range Sample and Trial Kits

- Specifically designed to evaluate Fastmount removable panel mounting styles

| | Item number |
|---|---|
| CD-03 Standard Profile A5 Sample Panel  | 606.8F50.200.000 Demonstrates PC-F1A, PC-M1A, PC-M2H, PC-SM2, PC-VM1 and PC-RF1 Standard Profile Range clips. Includes: CT-05 panel removal tool. |
| CT-06T Standard Profile Range Trial Kit Complete with Tools  | 606.8F60.201.060 Complete with clips and tools. Includes: PC-F1A x12, PC-M1A x12, PC-M2H x4, PC-SM2 x4, PC-SM2H, PC-VM1 x4, PC-RF1 x4, PC-SF1 x4, CP-01A x4, CT-01, CT-03, CT-05, CT-07, CT-09 and CT-10. |

Fastmount Panel Mounting Systems Standard Profile Range



Standard Profile Range Installation Tools

| | Item number |
|---|--|
| <p>CT-01 Standard Profile Drill, 10mm with Shoulder</p>  | <p>606.8F44.205.010</p> <p>Use with Standard Profile Range and Low Profile Range. For drilling through panel and pilot hole for CT-07.</p> |
| <p>CT-09 Standard Profile Drill, 10mm Forstner</p>  | <p>606.8F44.205.090</p> <p>Use with Standard Profile, Low Profile and Maxi Metal Range. To drill blind holes in the back of panels. See install guides and videos.</p> |
| <p>CT-07 Standard Profile Step Drill, Tungsten</p>  | <p>606.8F44.205.070</p> <p>Use with Standard Profile Range for PC-F1A, 16.8mm diameter tungsten tipped to drill out 10mm hole in frame. See install guides and video for correct use.</p> |
| <p>CT-013A Standard Profile Ø6.8mm Carbine Step Drill</p>  | <p>606.8F44.205.130</p> <p>Use with Standard Profile Range. To drill holes in fibreglass, carbon fibre and kevlar laminates.</p> |
| <p>CT-15 Standard Tap Insertion Tool</p>  | <p>606.8F44.206.150</p> <p>Use with Standard Profile Range. Tap tool for tapping thread to fit PC-F1A into fibre glass, aluminium, or similar. Drill hole with CT-13A or drill out 10mm hole with CT-07 then tap.</p> |

Fastmount Panel Mounting Systems

Standard Profile Range

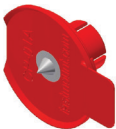
Standard Profile Range Installation Tools

| | Item number |
|---|--|
| <p>CP-01ST Centre Point Insertion Tool</p>  | <p>606.8F40.204.016</p> <p>Use to align holes in panel and frame when using blind holes in panel. Fits 10mm blind hole in panel (drilled with CT-09) or into PC-F1A, PC-SF1, PC-RF1 and PC-AF1. Stainless Steel tip option for hard material. Use CP-01A for softer materials.</p> |
| <p>CT-03 Standard Female Insertion Tool</p>  | <p>606.8F44.207.030</p> <p>Use with Standard Profile Range. For installation of self-tapping female PC-F1A using battery drill with correct torque setting.</p> |
| <p>CT-10 Standard Self-tapping Male Clip Insertion Tool</p>  | <p>606.8F44.207.100</p> <p>Use with Standard Profile, Low Profile, and Panel Control Range. For installation of self-tapping male PC-M1A, PC-M2H, PC-VM1, PS-150, and LP-M8 using battery drill with correct torque setting.</p> |

Fastmount Panel Mounting Systems Standard Profile Range

Standard Profile Range Installation Tools





| | Item number |
|--|--|
| <p data-bbox="165 797 478 824">CT-08 Standard Installation Kit</p>  A black plastic case containing several metal tools, including a screwdriver, a hex key, and a panel removal tool, arranged in a foam-lined interior. | <p data-bbox="884 797 1066 824">606.8F44.201.080</p> <p data-bbox="884 860 1423 945">Installation tools for Standard Profile Range of clips. One each CT-01, CT-03, CT-05, CT-07, CT-09, and CT-10 in plastic box.</p> |
| <p data-bbox="165 1348 600 1375">CT-06S Standard Profile Range Service Kit</p>  A black plastic case containing a variety of small white plastic clips, a black panel removal tool, and other maintenance components, arranged in a foam-lined interior. | <p data-bbox="884 1348 1066 1375">606.8F44.222.060</p> <p data-bbox="884 1406 1417 1518">For on-board maintenance of Standard Profile Range clips. Includes: PC-M1A x24, PC-M2H x4, PC-SM2 x4, PC-SM2H x4, CT-10 male clip tool and CT-05 covered panel removal tool.</p> |

Additional installation tools → See page 3.84

Fastmount Panel Mounting Systems

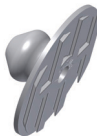
Low Profile Range

- Self-tapping and surface mount for a variety of substrates
- Suitable for rigid foam core, soft core materials, MDF and plasterboard
- 360 degree lateral adjustment, fitting into a Ø35 hole

| | Mounting | Item number | White |
|--|--|-----------------------|-------|
| LP-M8A Low Profile Self-tapping Male Clip  | TapFast | 606.8F22.122 → | 201 |
| | Screws into plywood and MDF type boards with 10mm hole. Mark with CP-08, drill with CT-09 and install with CT-10 install tool. Use with LP-F8 and LP-DF8 female clips. | | |
| LP-SM8As Low Profile Surface Mount Male Clip  | Surface | 606.8F22.222 → | 801 |
| | Adhesive fix super groove base onto panel or frame. Can also be screw fixed with #6 gauge self-tapping screw. Use with LP-F8 or LP-DF8 female Low Profile Range clips. | | |
| LP-F8 Low Profile Self-tapping Female Clip  | TapFast | 606.8F22.322 → | 201 |
| | Screws into plywood and MDF type boards with 25 to 25.4mm hole with CT-19 install tool. Use with LP-M8 and LP-SM8 male clips. | | |
| LP-DF8 Low Profile Self-tapping Female Clip, Coarse Thread  | TapFast | 606.8F22.322 → | 401 |
| | Screws into 25mm hole into drywall plasterboard and soft core material (rigid foam/balsa) from 10mm thick with CT-19 install tool, in battery drill with correct clutch setting. Use with LP-M8 and LP-SM8 male clips. | | |
| LP-AF8 Low Profile Female Auto Fit Clip  | Auto Fit | 606.8F22.322 → | 121 |
| | Female clip with lateral adjustment push fits into 35mm pre-drilled hole in deck head frame (grounds). Fits all Low Profile Range male clip halves. Designed for use with curved panels. | | |

Fastmount Panel Mounting Systems

Low Profile Range

- Specifically designed to evaluate Fastmount removable panel mounting styles



Low Profile Range Sample and Trial Kits

| | Item number |
|---|--|
| <p>CD-08 Low Profile Range Sample Panel</p>  | <p>606.8F50.220.000</p> <p>Demonstration panel for Low Profile Range series. Includes: LP-F8, LP-M8, LP-SM8 and LP-AF8.</p> |
| <p>LP-08T Low Profile Trial Kit</p>  | <p>606.8F60.221.080</p> <p>Complete with clips and tools. Includes: LP-F8 x12, WLP-DF8 x4, LP-AF8 x4, LP-M8 x8, LP-SM8 x4, CP-08 x4, CT-05, CT-10 and CT-20 with product sheets and installation guide.</p> |

Fastmount Panel Mounting Systems

Low Profile Range

Low Profile Range Installation Tools

| | Item number |
|--|--|
| <p>CP-08ST Low Profile Centre Clip Insert</p>  | <p>606.8F40.224.086</p> <p>Stainless steel tip center points for use with Low Profile Range clips LP-F8 and LP-DF8. Used to mark hard panel materials where plastic center point (CP-08) will not work.</p> |
| <p>CT-19 Low Profile Insertion Tool</p>  | <p>606.8F44.227.194</p> <p>Aluminium install tool for female clips LP-F8 and LP-DF8 Low Profile Range. Use in battery drill with correct clutch setting.</p> |
| <p>CT-20 Low Profile Insertion Tool</p>  | <p>606.8F44.227.206</p> <p>Red plastic moulded install tool for female clips LP-F8 and LPDF8 Low Profile Range. Use in battery drill with correct clutch setting. For normal use, for large quantity installs use CT-19.</p> |

Fastmount Panel Mounting Systems

Low Profile Range

Low Profile Range Installation Tools

| | Item number |
|--|---|
| <p>LP-08Y Low Profile Installation Kit</p>  | <p>606.8F44.221.060</p> <p>Contains tools for installing Low Profile Range clips (LP-F8, LPDF8, LP-M8) and panel removal tool (covered panels). Plastic box with CT-05, CT-09, CT-10 and CT-20 x1.</p> |
| <p>CT-01 Standard Profile Drill, 10mm with Shoulder</p>  | <p>606.8F44.205.010</p> <p>Use with Standard Profile Range and Low Profile Range. For drilling through panel and pilot hole for CT-07.</p> |
| <p>CT-09 Standard Profile Drill, 10mm Forstner</p>  | <p>606.8F44.205.090</p> <p>Use with Standard Profile, Low Profile and Maxi Metal Range. To drill blind holes in the back of panels. See install guides and videos.</p> |
| <p>CT-10 Standard Self-tapping Male Clip Insertion Tool</p>  | <p>606.8F44.207.100</p> <p>Use with Standard Profile, Low Profile, and Panel Control Range. For installation of self-tapping male PC-M1A, PC-M2H, PC-VM1, PS-150, and LP-M8 using battery drill with correct torque setting.</p> |

Additional Installation Tools → See page 3.84

Fastmount Panel Mounting Systems

Very Low Profile Range

- Self-aligning secure mounting (min. 5kg per clip)
- Quick installation requires no special tools or skilled labour
- Clip lead-in for easy fitting
- Can be screw fixed with lateral adjustment

| | Mounting | Item number | Silver |
|---|------------------|-----------------------|--------|
| VL-03 Very Low Profile Clip Set  | Surface Recessed | 606.8F24.122 → | 101 |
| <p>For surface or recessed mounting. Can be screw or glue fixed. Versatile clip able to be installed without special tools. Pull-out load 5kg per clip. VL-03 set packed 100 per bag with VL-M3 + VL-SS3 inner bag, VL-F3 in outer bag. Now supplied with stainless steel screw (VL-SS3).</p> | | | |
| VL-M3 Very Low Profile Male Screw on Surface Mount Clip  | Surface | 606.8F24.222 → | 101 |
| <p>Male clip half for surface mounting. Can be screw fixed with lateral adjustment or glue fixed. Versatile clip able to be installed without special tools. Pull-out load 5kg per clip. The VL-M3 is used with VL-F3 + VL-SS3.</p> | | | |
| VL-F3 Very Low Profile Female Screw on Clip  | Surface Recessed | 606.8F24.322 → | 101 |
| <p>Female clip half for surface or recessed mounting. Can be screw or glue fixed. Versatile clip able to be installed without special tools. Pull-out load 5kg per clip use with VL-M3.</p> | | | |

Fastmount Panel Mounting Systems

Very Low Profile Range

- Self-aligning secure mounting (min. 10kg per clip)
- Quick installation requires no special tools or skilled labour
- Clip lead-in for easy fitting
- Can be screw fixed with lateral adjustment



| | Mounting | Item number | Black | Stainless steel |
|--|------------------|-----------------------|-------|-----------------|
| VL-03H Very Low Profile Heavy Duty Clip Set  | Surface recessed | 606.8F24.522 → | 004 | |
| <p>Male and female very low profile heavy duty system designed for surface or recessed mounting of heavier panels. 10 kg pull-out load per clip set. Can be glue or screw fixed with VL-SS3. No special tools required for installation. Supplied with stainless steel screw VL-SS3.</p> | | | | |
| VL-M3H Very Low Profile Heavy Duty Male Clip  | Surface | 606.8F24.224 → | 000 | |
| <p>Male very low profile surface mount clip. Compatible with female clip VL-F3H. 10 kg pull-out load per clip set. Can be glue or screw fixed with VL-SS3. No special tools required for installation.</p> | | | | |
| VL-F3H Very Low Profile Heavy Duty Female Clip  | Surface recessed | 606.8F24.124 → | 101 | |
| <p>Female very low profile heavy duty clip for surface or recessed mounting. Compatible with male clip VL-M3H. 10 kg pull-out load per clip set. Epoxy glue or screw fix with VL-SS3. No special tools required for installation.</p> | | | | |
| VL-SS3 Very Low Profile Screw  | Screw-in | 606.8F24.523 → | | 004 |
| <p>Custom type 303 stainless steel screw for fixing VL-03 and VL-03H clip sets into panels as thin as 5.5mm. Pozi drive head. Supplied with VL-03 and VL-03H clip sets.</p> | | | | |

Fastmount Panel Mounting Systems

Very Low Profile Range

- Specifically designed to evaluate Fastmount removable panel mounting styles

Very Low Profile Range Sample and Trial Kits

| | Item number |
|---|--|
| <p>CD-VL3 Very Low Profile Sample Panel</p>  | <p>606.8F50.240.000</p> <p>Demonstration panel for Very Low Profile Range clip series. VL-03 = VL-F3 + VL-M3.</p> |
| <p>LP-03T Very Low Profile Trial Kit</p>  | <p>606.8F60.241.030</p> <p>Includes: VL-F3 x10, VL-M3 x10, VL-SS3 x10 and VL-CP x2 with metal tip, plus information pack.</p> |

Very Low Profile Range Installation Tools

| | Item number |
|--|---|
| <p>VL-CP3 Very Low Profile Centre Point Insert</p>  | <p>606.8F40.244.036</p> <p>Center point for Very Low Profile Range clips VL-F3 and VL-M3. Use to mark hole centre in panel for correct clip alignment. Has stainless steel tip for marking panel or frame. Tip: push fits into either side of nylon moulding. See install guide.</p> |

Additional Installation Tools → See page 3.84

Fastmount Panel Mounting Systems

Metal Range

- Metal clip to withstand high temperatures
- Allows for tolerance & panel flex (self-centering)
- Provides acoustic & vibration isolation
- 10kg pull-out load

| | Mounting | Item number | Grey metal |
|---|---|-----------------------|------------|
| MC-05 Metal Range Panel Clip Set, 5kg  | TapFast / Screw-on | 606.8F30.122 → | 204 |
| | <p>Ideal for fire rated panels the MC-05 is designed to withstand high temperatures and also provides acoustic and vibration isolation. The self-centering design allows for tolerance and panel flexing. Self-tapping with MC-IT5 and screw fit installation options. Can be used in conjunction with Standard Profile Range Clips. MC-05 = MC-F5 + MC-M5. 5kg pull-out load.</p> | | |
| MC-10 Metal Range Maxi Clip Set, 10kg  | TapFast / Screw-on | 606.8F30.324 → | 804 |
| | <p>Ideal for fire rated panels the MC-10 is designed to withstand high temperatures and also provides acoustic and vibration isolation. The self-centering design allows for tolerance and panel flexing. Self-tapping with MC-IT5 and screw fit installation options. Can be used in conjunction with Standard Profile Range Clips. MC-10 = MC-F10 + MC-M5. 10kg pull-out load.</p> | | |
| MC-F10 Metal Range Self-tapping Female Clip, 10kg  | TapFast / Screw-on | 606.8F30.324 → | 204 |
| | <p>Female half of metal clip set MC-10 (black centre), use with MC-M5. Self-tapping with MC-IT5, and screw fit installation with #5 gauge screws.</p> | | |
| MC-F5 Metal Range Self-tapping Female Clip, 5kg  | TapFast / Screw-on | 606.8F30.322 → | 804 |
| | <p>Female half of metal clip set MC-05 (white centre), use with MC-M5. Self-tapping with MC-IT5, and screw fit installation with #5 gauge screws.</p> | | |

Fastmount Panel Mounting Systems

Metal Range

| | Mounting | Item number | Grey metal |
|--|----------|-----------------------|------------|
| MC-M5 Metal Range Self-tapping Male Clip, 5kg  | TapFast | 606.8F30.222 → | 204 |
| Self-tapping male half of Maxi Metal Clip Set fits MC-F5 and MC-F10. Install with MC-IT5. | | | |

- Sample kits are specifically designed to evaluate the Fastmount Metal Range panel mounting system

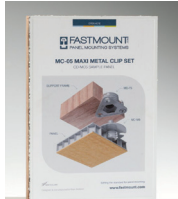

Metal Range Sample Kits

| | Item number |
|---|--|
| CD-MC5 Metal Range Sample Panel Kit  | 606.8F50.300.000 Demonstration panel for Maxi Metal Range clips with MC-F5 + MC-M5H. |

Fastmount Panel Mounting Systems

Metal Range

Metal Range Installation Tools





| | Item number |
|---|---|
| <p>MC-CP5 Metal Range Centre Point Insert</p>  | <p>606.8F40.304.056</p> <p>Centre point fits MC-F5 metal clip. Use to mark hole centre in panel, for correct clip alignment. Has stainless steel tip for marking panel. Refer to install guide.</p> |
| <p>MC-IT5 Install Tool for Metal Clip MC-F5 and MC-M5</p>  | <p>606.8F44.418.054</p> <p>For installation of self-tapping male MC-M5H, can also be used for MC-F5 into plywood or similar. Use battery drill with correct torque setting. Refer to installation video.</p> |
| <p>CT-09 Standard Profile Drill, 10mm Forstner</p>  | <p>606.8F44.205.090</p> <p>Use with Standard Profile, Low Profile and Maxi Metal Range. To drill blind holes in the back of panels. See install guides and videos.</p> |

Additional Installation Tools → See page 3.84

Fastmount Panel Mounting Systems

Panel Control Range





- Secures heavy panels
- Easy one person removal of large panels
- Prevents panels falling during fire exit
- Works with existing Fastmount clips

| | Mounting | Item number |
|--|---|--------------------------|
| <p>PS-150E Panel Safe Easy Fit Self-tapping Clip, 150mm</p>  | TapFast | 606.8F36.122.205 |
| | <p>Suspends panel on removable stainless steel wire strops. Suitable for use in conjunction with any of the Fastmount range of clips. Standard drop length 150mm, with custom lengths available on request. Install with CT-10. Note: custom products have a six-week lead time.</p> | |
| <p>PS-S150E Panel Safe Easy Fit Surface Mount Clip, 150mm</p>  | Surface | 606.8F36.122.805 |
| | <p>Suspends panel on removable stainless steel wire strops. Suitable for use in conjunction with any of the Fastmount range of clips. Standard drop length 150mm, with custom lengths available on request. Glue or screw fix to panel. Note: custom products have a six-week lead time.</p> | |
| <p>PS-150 Panel Safe Clip, 150mm</p>  | TapFast | 606.8F36.122.215 |
| | <p>Suspends panel on removable stainless steel wire strops. Suitable use in conjunction with any of the Fastmount range of clips. Standard drop length 150mm, with custom lengths available on request. Install with CT-07, CT-03 and CT-10. Note: custom products have a six-week lead time.</p> | |
| <p>PS-Custom Panel Safe Customer Length</p>  | TapFast | 606.8F36.100.000* |
| | <p>Specify required type and length. Use with Fastmount system clips. PS-S custom, surface mount option and easy fit or standard options available. Custom lengths from 50mm to 500mm.</p> <p>*Available on request.</p> | |

Fastmount Panel Mounting Systems

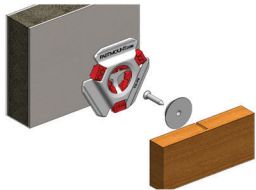
Textile Range

- Enables the attachment of soft furnishings to hard surfaces and makes furnishings quick to install and remove
- Easy alignment to replace the cushion
- Invisible fixing – no visible domes, screws, straps or hook and loop
- 10kg break-out load

| | | Mounting | Item number |
|---|--|---|-------------------------|
| TC-06 Textile Range Clip Set  | | Screw-on | 606.8F37.122.060 |
| | | Textile Clip Set = TC-M6 + TC-F6 Secure textile and soft furnishing clip system. Ensures fast, precise cushion fixing, and fast cushion removal. | |
| TC-F6 Female Textile Clip  | | Screw-on | 606.8F37.322.260 |
| | | Enables the attachment of soft furnishings to hard surfaces and makes furnishings quick to install and remove. High quality, secure finish. Easy alignment to replace the cushion. Invisible fixing. 10kg break-out load. | |
| TC-M6 Male Textile Clip  | | Screw-on | 606.8F37.222.160 |
| | | Enables the attachment of soft furnishings to hard surfaces and makes furnishings quick to install and remove. High quality, secure finish. Easy alignment to replace the cushion. Invisible fixing. 10kg break-out load. | |
| TC-R6 Textile Range Clip Removal Tool  | | | 606.8F44.418.060 |
| | | No force required to remove the furnishing – simply press one of the three buttons to disengage the block. Saves removal time for staff and crew. | |

Fastmount Panel Mounting Systems

Textile Range

Textile Range Sample and Trial Kits

| | Item number |
|--|--|
| <p>TC-06T Textile Range Sample Panel and Trial Kit</p>  | <p>606.8F60.261.060</p> <p>A4 size cushion sample panel demonstrating TC-F6 and TC-M6 from the Textile Range. 4 x TC-F6, 4 x TCM6, 2 x TC-CP6, 1 x TC-R6.</p> |

Textile Range Installation Tools

| | Item number |
|--|--|
| <p>TC-CP6 Textile Range Centre Point Insert</p>  | <p>606.8F40.404.060</p> <p>Textile Range centre point with stainless steel tip to mark hole centre in panel for correct clip alignment. See install guide for additional information.</p> |

Additional Installation Tools → See page 3.84

Fastmount Panel Mounting Systems

Additional Installation Tools





- Installation tools designed specifically for the Fastmount panel mounting systems

| | Item number |
|--|--|
| <p>CT-12 HSS Countersink Drill Bit, 31mm with 10mm Shank</p>  | <p>606.8F44.415.054</p> <p>To be used to countersink entry edge of hole (1-2mm) in hard materials such as MDF, hard plywood, fibre glass, plastic. Use when drilling holes for PC-M1B, PC-M2H, PC-VM1, PC-VM1H, LP-M8, LP-F8 and LP-DF8.</p> |
| <p>CT-18 Guide Drill</p>  | <p>606.8F44.415.184</p> <p>Use with Standard Profile Range. Drill guide for PC-RF1 mounting options.</p> |
| <p>CT-05 Panel Removal Tool</p>  | <p>606.8F44.418.050</p> <p>Stainless steel tool for removing covered (upholstered) panels. Do not use with painted panels.</p> |
| <p>CT-17 Panel Removal Tool, Painted Panel</p>  | <p>606.8F44.418.170*</p> <p>Panel removal and handling, using a glass suction cup for painted and prefinished panels. Always use two glass suckers to control panel removal.</p> |
| <p>CT-09DG Drill Gauge for CT-09 Drill Bit</p>  | <p>606.8F44.205.091</p> <p>Drill Gauge for use with CT-09 drill bit. Designed for depth control when blind drilling for Standard and Low Profile range male clips. Machined aluminium housing, anodised red for durability. NOTE: Sold separately to CT-09.</p> |

Fastmount Panel Mounting Systems

SuperGroove™ Adhesive

- High strength 2-part glue bonds to most substrates
- Quick 10-minute curing
- Non-toxic
- Ideal for Fastmount SuperGroove™ surface mount clips

| | Item number |
|---|--|
| <p>CG-3010 SuperGroove™ Adhesive, 30ml</p>  | <p>606.8F38.200.030*</p> <p>Fastmount SuperGroove Adhesive™ 30ml twin tube manual dispenser for use with the Fastmount Surface Mount range. 10-minute cure, solvent-free, non-toxic, no VOCs, RoHS and REACH compliant, 12-month shelf life. Ideal for small installations and emergency repairs. Proportional 1:1 mixing. No additional equipment required.</p> |
| <p>CG-40010 SuperGroove™ Adhesive, 400ml</p>  | <p>606.8F38.200.400*</p> <p>Fastmount SuperGroove Adhesive™ 400ml twin tube dispenser with self-mixing nozzle for use with Fastmount Surface Mount range. 10-minute cure, solvent-free, non-toxic, no VOCs, RoHS and REACH compliant, 12-month shelf life. Ideal for large scale installations. Supplied with two self-mixing nozzles for proportional mixing. Use with SuperGroove Adhesive Gun (sold separately). Additional self-mixing nozzles can be purchased.</p> |
| <p>CG-400MT SuperGroove™ Adhesive Self-mixing Nozzles</p>  | <p>606.8F38.201.000*</p> <p>Pack of 5 disposable self-mixing nozzles designed for use with CG-40010 SuperGroove Adhesive™ 400ml. NOTE: Glue not included.</p> |
| <p>CG-400G SuperGroove™ Adhesive Gun for 400ml Tube</p>  | <p>606.8F38.201.400*</p> <p>SuperGroove Adhesive™ gun designed for use with CG-40010 SuperGroove Adhesive™ 400ml twin tube. Robust steel construction.</p> |