

Titus Tekform
Product brochure



**Tekform
Single
Wall
Drawer**

2016

Important Information

Intellectual property

Titus Group owns the intellectual property rights in its products worldwide whether as trademarks, patents, intellectual, copyright, designs, illustrations, drawings and the 'know how' contained in their design and production. Titus Group respects the equivalent rights in competitors and all other relevant product design rights in others. To our knowledge our products do not infringe any intellectual property rights of competitors or other parties. Titus Group takes infringements of its rights seriously and will rigorously defend these rights to the full extent of the law.

Responsibility

It is the responsibility of the user to ensure the fitness of hardware for the intended purpose. We recommend assessment by appropriate testing in the application and by technical enquiry to our representatives.

Technical information

While every effort has been made in the production of this catalogue to ensure the accuracy of information, our products are continually being revised and users should confirm the up to date specification before ordering.

*Non preferred articles

All Item numbers in the catalogue marked with * are for non preferred non stock items available upon special request. For such products, extended delivery times may apply.

Trademarks

Titus and Titusonic are registered trademarks of Titus International Ltd. Lama is a registered trademark of Lama d.d. Dekani, WoodWelding is a registered trademark of WW SA.

Single Wall Drawer Systems



Tekform drawer SW85



Tekform drawer SW117



Tekform drawer SW150



Tekform drawer SW210

Versatile and Reliable

The single-wall Tekform drawer is the right solution to solve kitchen, wardrobe and bathroom vanity drawer applications. Both strong and affordable, the drawer's fluid sliding movement is due to the use of a roller slide system, whilst the epoxy coating makes it silent during operation. The product is available in a large range of heights and depths. The immediate vertical adjustment makes the drawer very versatile and easy to use; it is also ideal both for automatic and manual assembly.

Lifetime warranty

- 50,000 cycle tested lifetime warranty

Quality certified

- By European specialized institutions
- Level 5 Heavy Domestic
- CATAS
- FIRA

Tekform Single Wall Drawer



Easy front fixing

- Front clips available for all drawer fixing methods
- Spring loaded action for easy location of the drawer front

User friendly mounting

- Intuitive installation instructions
- Easy assembly and disassembly of the drawer
- Assembly equipment available

Precise drawer alignment

- Huge vertical cam adjustment
- Provides a total +/- 4mm adjustment
- Side adjustment +/- 1.5mm

Tekform Drawer SW85

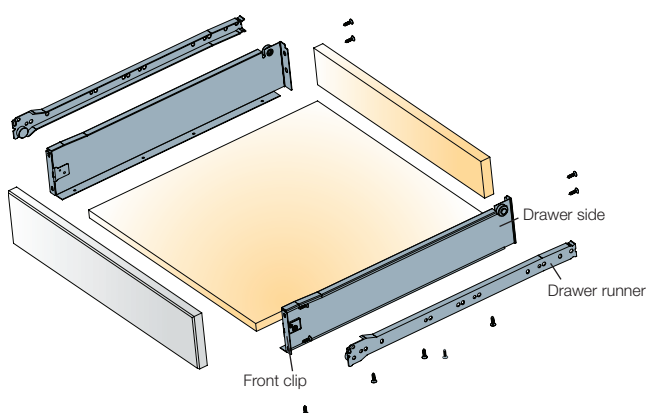
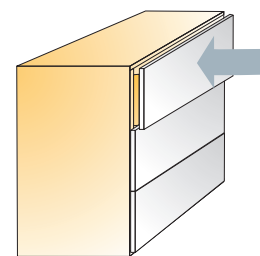

Cutting dimensions details

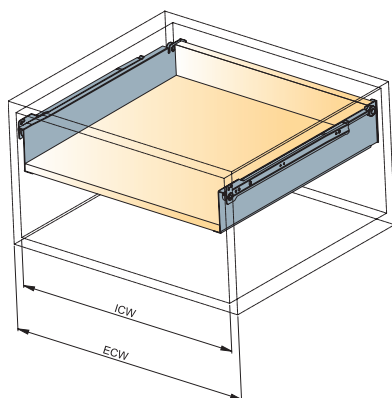

ECW: External cabinet width
ICW: Internal cabinet width
NL: Nominal length of drawer

Bottom panel

Back panel

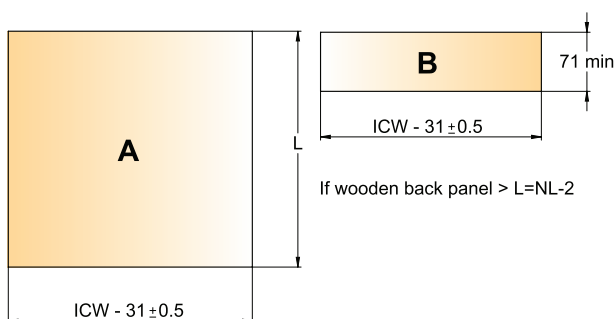

1 Pair



May be use with Titusoft damper for metal drawers (MD) or the Titus Push Latch.

Push latch → page 15



Titusoft MD → page 13

Nominal length	with Tekform front clip		White	
	Item number			
Machine insertion	500	603.8C68.050 →	150	
Screw on	250	603.8C61.025 →	150	
	270	603.8C61.027 →	150	
	350	603.8C61.035 →	150	
	400	603.8C61.040 →	150	
	450	603.8C61.045 →	150	
	500	603.8C61.050 →	150	
	550	603.8C61.055 →	150	
	C15 pin assembly	250	603.8C62.025 →	150
		270	603.8C62.027 →	150
		350	603.8C62.035 →	150
400		603.8C62.040 →	150	
450		603.8C62.045 →	150	
500		603.8C62.050 →	150	
550	603.8C62.055 →	150		
One set consists of				
Drawer sides			2 pcs	
Drawer runner			2 pcs	
Front clips			2 pcs	
Mounting instructions			1 pce	

- Large range of dimensions from 250 to 550 mm depth
- Screw on, dowel fixing machine insertion ready or C15 assembly options
- Simple bottom mounting for ease of assembly
- Unilateral restraint-guide compensates for tolerances

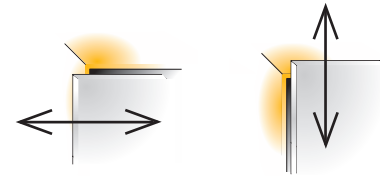

Side adjustment
+/- 1.5mm

Height adjustment
+/- 2.5mm

- **Drawer runner type** Single extension roller
- **Load capacity** 25kg
- **Minimal height space required** 106.5mm
- **Wooden back panel thickness** 12-18mm

Installation dimensions and drilling patterns

Drawer runner fixing positions

Front panel drilling pattern

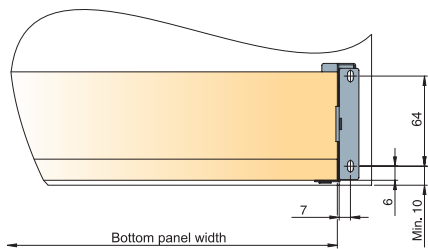

Back panel drilling pattern

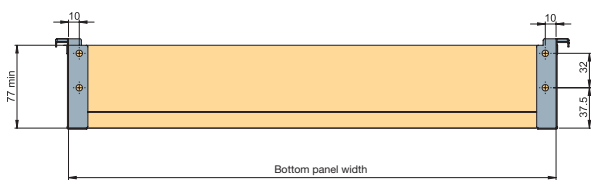

Installation and back panel dimensions

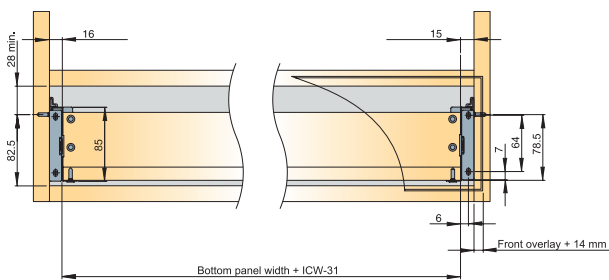

Drawer runner mounting

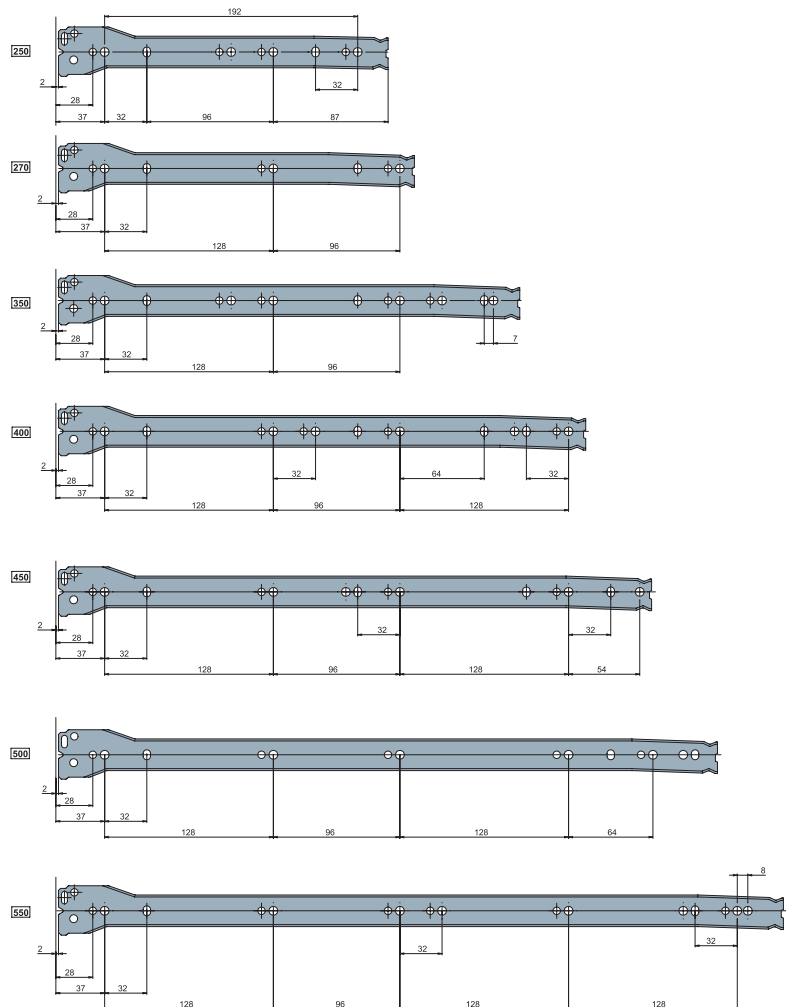
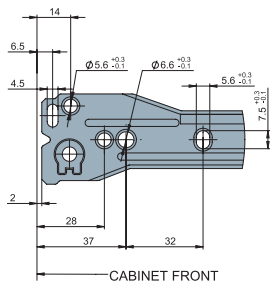

Fixing screws for front brackets and drawer runner

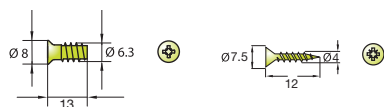

Euro screws
611.8E22.360.013

Chipboard screws
611.8K16.240.016

10000 Pcs

A trial mounting is always recommended. For further information please contact your Titus Tekform representative.

Tekform Drawer SW117

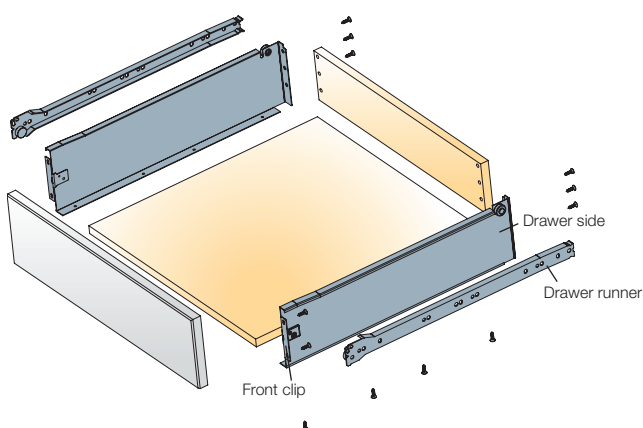
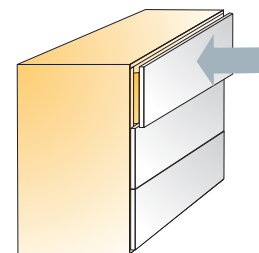

Cutting dimensions details

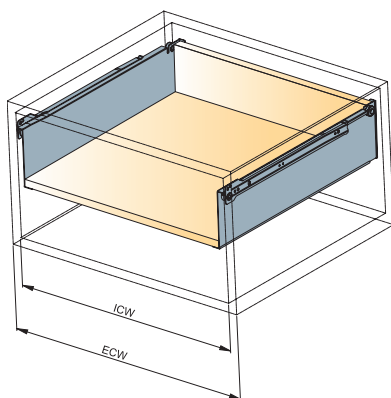

ECW: External cabinet width
ICW: Internal cabinet width
NL: Nominal length of drawer

Bottom panel

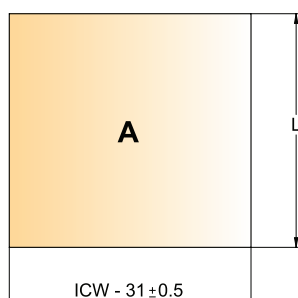

Back panel

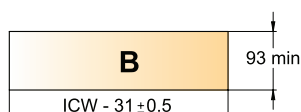



If wooden back panel > L=NL-2

1 Pair

Screw on

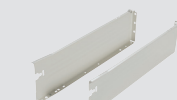
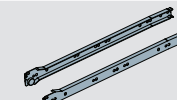
C15 pin assembly

NL	with Tekform front clip	White
Nominal length	Item number	
250	603.8C71.025 →	150
270	603.8C71.027 →	150
350	603.8C71.035 →	150
400	603.8C71.040 →	150
450	603.8C71.045 →	150
500	603.8C71.050 →	150
550	603.8C71.055 →	150
250	603.8C72.025 →	150
270	603.8C72.027 →	150
350	603.8C72.035 →	150
400	603.8C72.040 →	150
450	603.8C72.045 →	150
500	603.8C72.050 →	150
550	603.8C72.055 →	150
One set consists of		
Drawer sides		2 pcs
Drawer runner		2 pcs
Front connectors		2 pcs
Mounting instructions		1 pce



May be use with Titusoft damper for metal drawers (MD) or the Titus Push Latch.

Push latch → page 15



Titusoft MD → page 13

- Large range of dimensions from 250 to 550 mm depth
- Screw on, dowel fixing machine insertion ready or C15 assembly options
- Simple bottom mounting for ease of assembly
- Unilateral restraint-guide compensates for tolerances

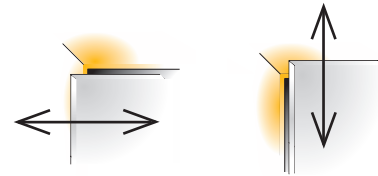

Side adjustment
+/- 1.5 mm

Height adjustment
+/- 2.5mm

- Drawer runner type Roller slides
- Load capacity 25kg
- Minimal height space required 138.5mm
- Wooden back panel thickness 12-18mm

Installation dimensions and drilling patterns

Drawer runner fixing positions

Front panel drilling pattern

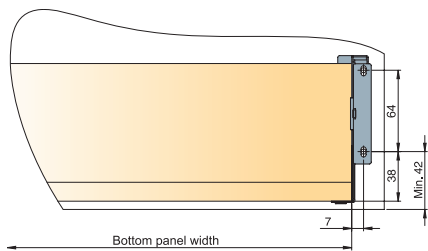

Back panel drilling pattern

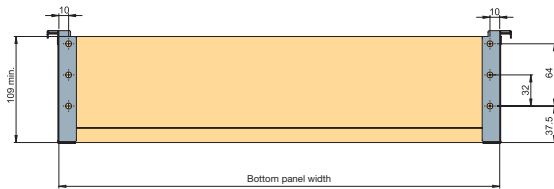

Installation and back panel dimensions

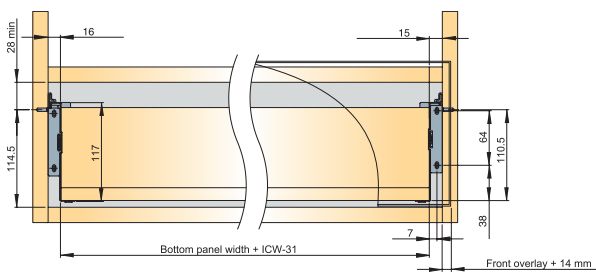

Drawer runner mounting

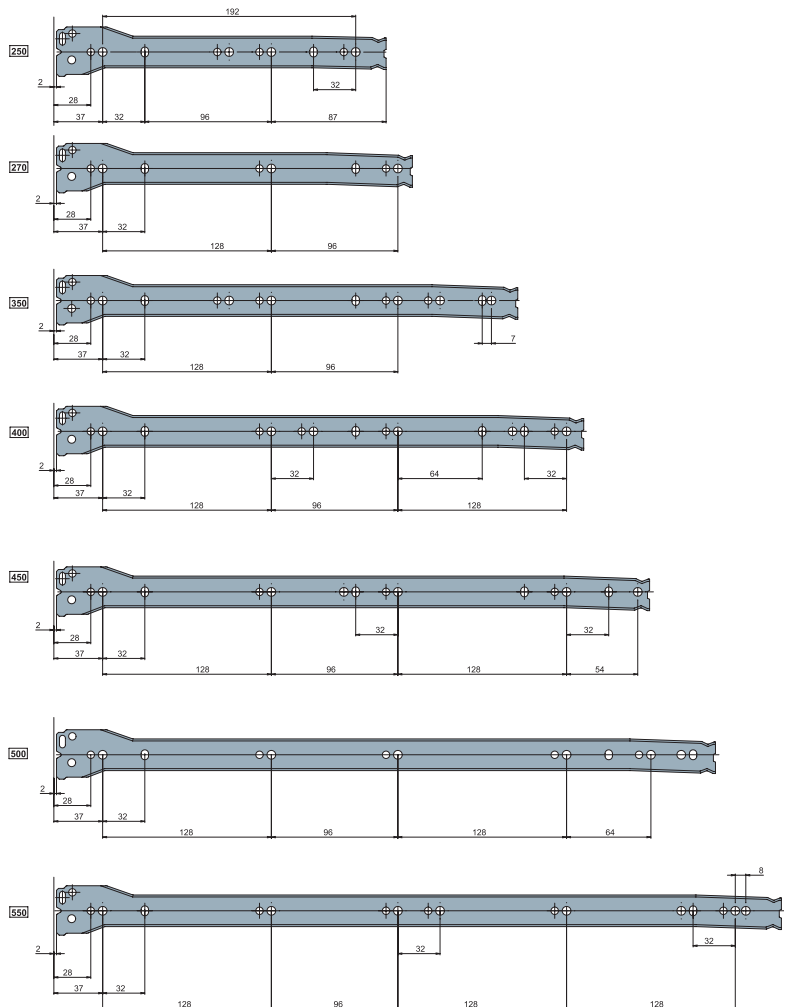
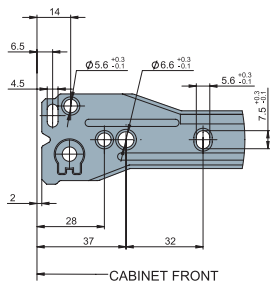

Fixing screws for front brackets and drawer runner

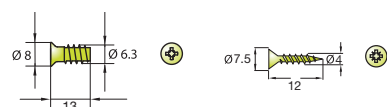

Euro screws
611.8E22.360.013

Chipboard screws
611.8K16.240.016

10000 Pcs

A trial mounting is always recommended. For further information please contact your Titus Tekform representative.

Tekform Drawer SW150

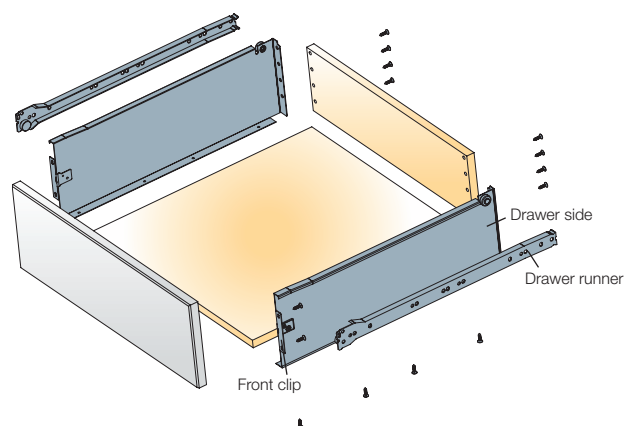
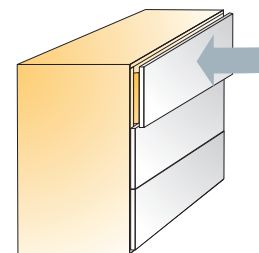

Cutting dimensions details

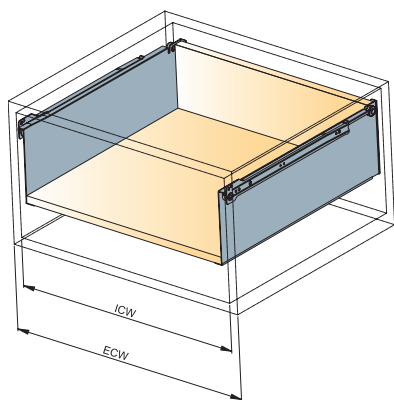

ECW: External cabinet width
ICW: Internal cabinet width
NL: Nominal length of drawer

Bottom panel

Back panel

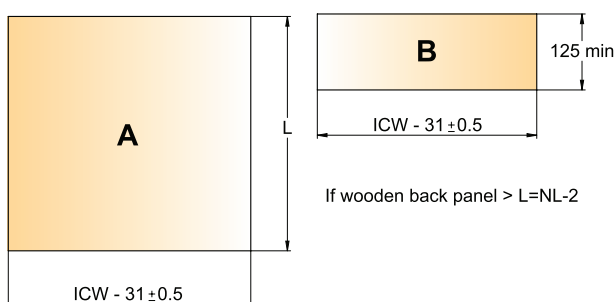

 1 Pair



May be use with Titusoft damper for metal drawers (MD) or the Titus Push Latch.



Push latch → page 15



Titusoft MD → page 13

Screw on

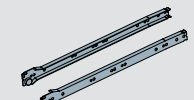
C15 pin assembly

Nominal length	with Tekform front clip		White
	Item number		
250	603.8C81.025 →	150	
270	603.8C81.027 →	150	
350	603.8C81.035 →	150	
400	603.8C81.040 →	150	
450	603.8C81.045 →	150	
500	603.8C81.050 →	150	
550	603.8C81.055 →	150	
250	603.8C82.025 →	150	
270	603.8C82.027 →	150	
350	603.8C82.035 →	150	
400	603.8C82.040 →	150	
450	603.8C82.045 →	150	
500	603.8C82.050 →	150	
550	603.8C82.055 →	150	
One set consists of			
Drawer sides		2 pcs	
Drawer runner		2 pcs	
Front clips		2 pcs	
Mounting instructions		1 pce	

- Large range of dimensions from 250 to 550 mm depth
- Screw on, dowel fixing machine insertion ready or C15 assembly options
- Simple bottom mounting for ease of assembly
- Unilateral restraint-guide compensates for tolerances

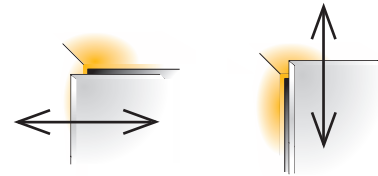

Side adjustment
+/- 1.5 mm

Height adjustment
+/- 2.5mm

- Drawer runner type Roller slides
- Load capacity 25kg
- Minimal height space required 170.5mm
- Wooden back panel thickness 12-18mm

Installation dimensions and drilling patterns

Drawer runner fixing positions

Front panel drilling pattern

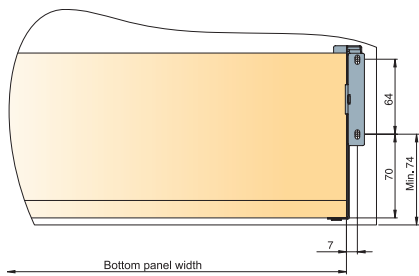

Back panel drilling pattern

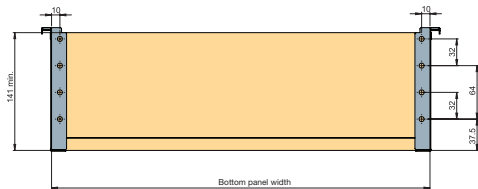

Installation and back panel dimensions

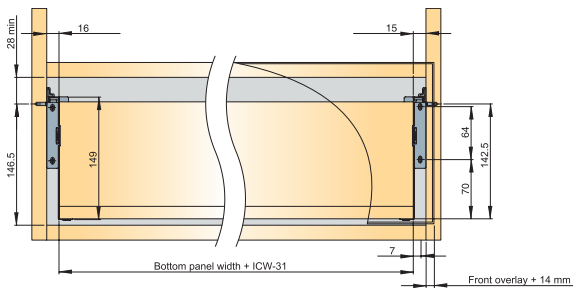

Drawer runner mounting

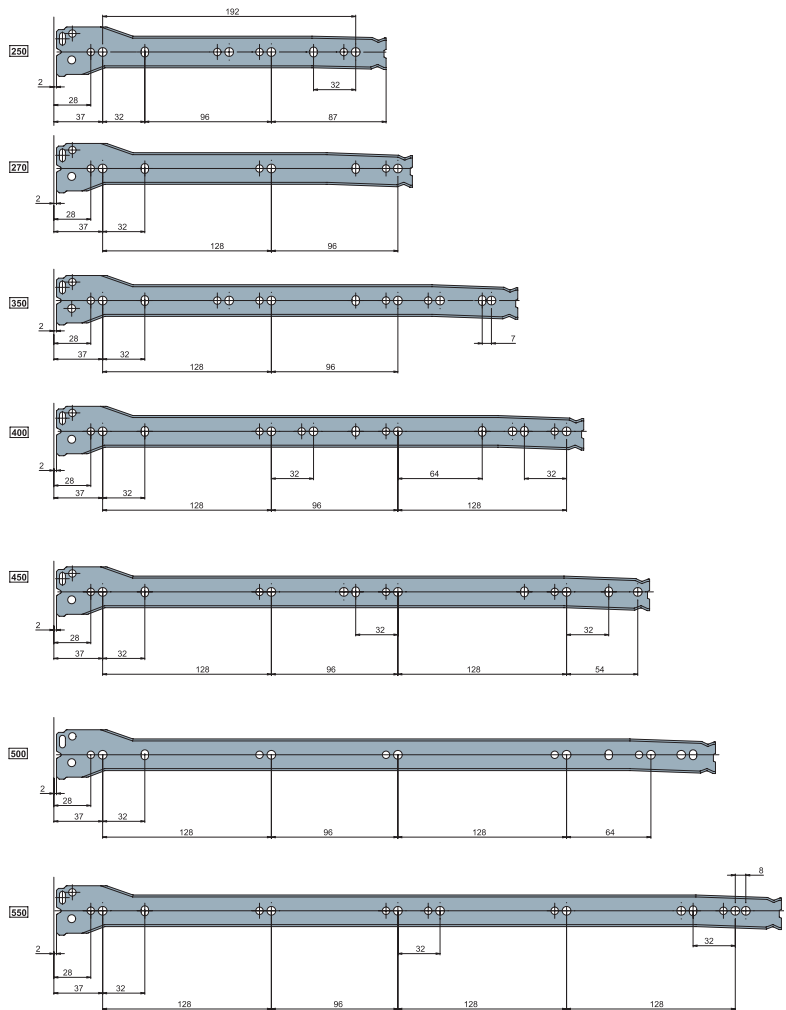
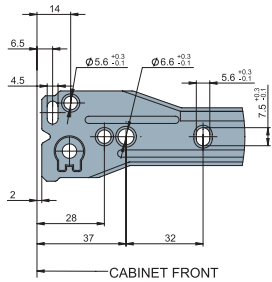

Fixing screws for front brackets and drawer runner

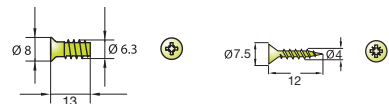

Euro screws
611.8E22.360.013

Chipboard screws
611.8K16.240.016

10000 Pcs

A trial mounting is always recommended. For further information please contact your Titus Tekform representative.

Tekform Drawer SW210

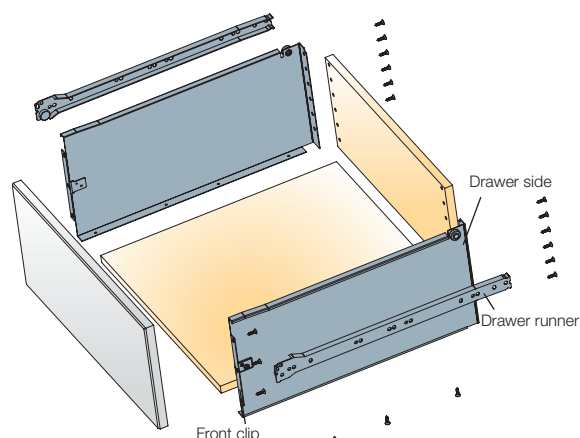
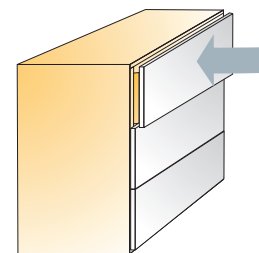

Cutting dimensions details

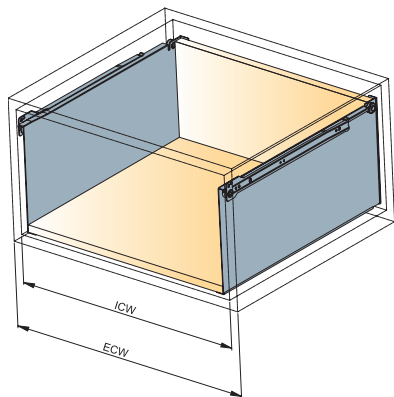

ECW: External cabinet width
ICW: Internal cabinet width
NL: Nominal length of drawer

Bottom panel

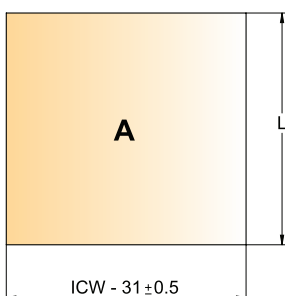

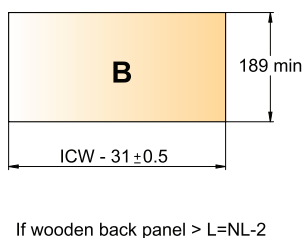

Back panel



1 Pair

Screw on

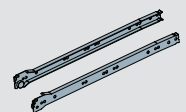
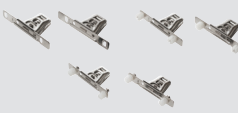
C15 pin assembly

NL	with Tekform front clip	White
Nominal length	Item number	
250	603.8C91.025 →	150
270	603.8C91.027 →	150
350	603.8C91.035 →	150
400	603.8C91.040 →	150
450	603.8C91.045 →	150
500	603.8C91.050 →	150
550	603.8C91.055 →	150
250	603.8C92.025 →	150
270	603.8C92.027 →	150
350	603.8C92.035 →	150
400	603.8C92.040 →	150
450	603.8C92.045 →	150
500	603.8C92.050 →	150
550	603.8C92.055 →	150
One set consists of		
Drawer sides		2 pcs
Drawer runner		2 pcs
Front clips		2 pcs
Mounting instructions		1 pce



May be use with Titusoft damper for metal drawers (MD) or the Titus Push Latch.

Push latch → page 15



Titusoft MD → page 13

- Large range of dimensions from 250 to 550 mm depth
- Screw on, dowel fixing machine insertion ready or C15 assembly options
- Simple bottom mounting for ease of assembly
- Unilateral restraint-guide compensates for tolerances

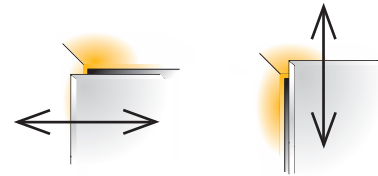

Side adjustment
+/- 1.5 mm

Height adjustment
+/- 2.5mm

- Drawer runner type **Roller slides**
- Load capacity **25kg**
- Minimal height space required **233.5mm**
- Wooden back panel thickness **12-18mm**

Installation dimensions and drilling patterns

Drawer runner fixing positions

Front panel drilling pattern

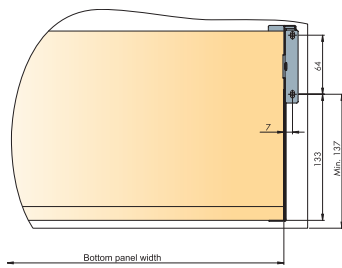

Back panel drilling pattern

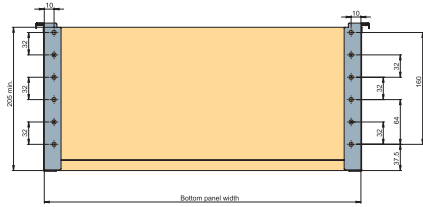

Installation and back panel dimensions

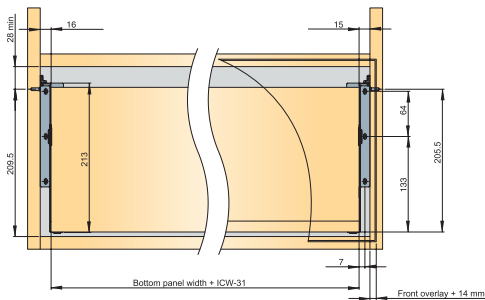

Drawer runner mounting

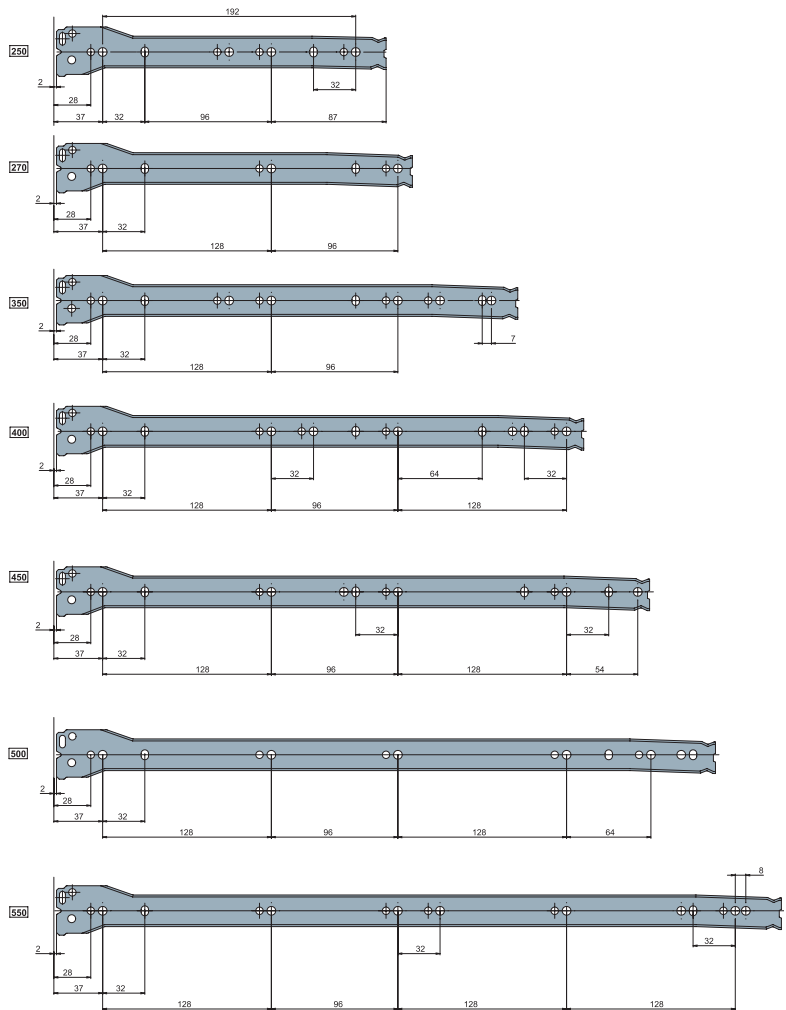
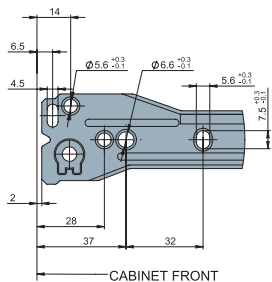

Fixing screws for front brackets and drawer runner

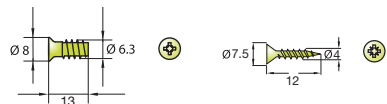



Euro screws
611.8E22.360.013

Chipboard screws
611.8K16.240.016

10000 Pcs

A trial mounting is always recommended. For further information please contact your Titus Tekform representative.



Accessories

			Side	Mounting	Item number	
<p>Front Clips</p>  <p>Screw on</p>  <p>Machine insertion 10mm</p>  <p>Expanding dowel 10mm</p>	Front Clips	Right	Screw on	603.8C46.005		
		Left	Screw on	603.8C46.006		
		Right	Machine insertion	603.8C46.010		
		Left	Machine insertion	603.8C46.012		
		Right	EFS	603.8C46.015		
		Left	EFS	603.8C46.016		

 1 Pce

Accessories

- Improved storage in high drawers
- Clips for wooden and metal backs
- Easy one-step fixing and screw-on front attachment
- Lasting quality

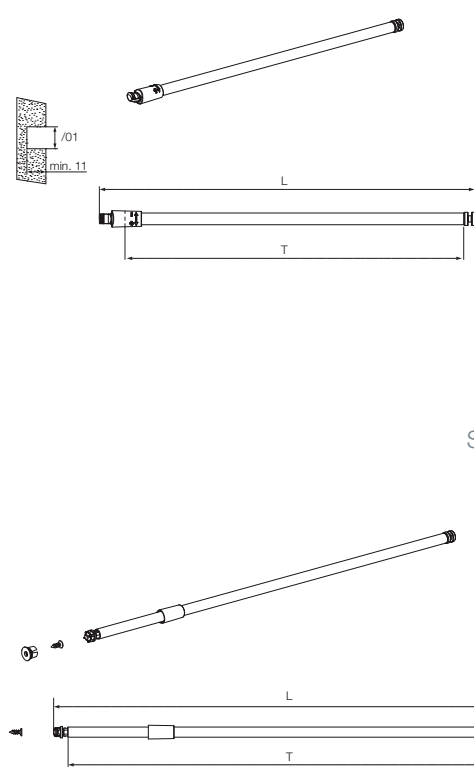
		Length (mm)	Item number	White	
<p>Round Railing</p> <div style="display: flex; justify-content: space-around;"> <div style="text-align: center;">  <p>EasyFix Railing</p> </div> <div style="text-align: center;">  <p>Screw-on Railing</p> </div> </div> <div style="text-align: center; margin-top: 20px;">  </div>	EasyFix	250	603.8C98 →	025	
		270	603.8C98 →	027	
		350	603.8C98 →	035	
		400	603.8C98 →	040	
		450	603.8C98 →	045	
		500	603.8C98 →	050	
		550	603.8C98 →	055	
		Screw-on	250	603.8C98 →	125
			270	603.8C98 →	127
			350	603.8C98 →	135
			400	603.8C98 →	140
			450	603.8C98 →	145
			500	603.8C98 →	150
		550	603.8C98 →	155	
	Back bracket (wood)		603.8C98 →	200	

 1 Pair

Titusoft MD

Soft Closing System for Metal Box

For metal boxes

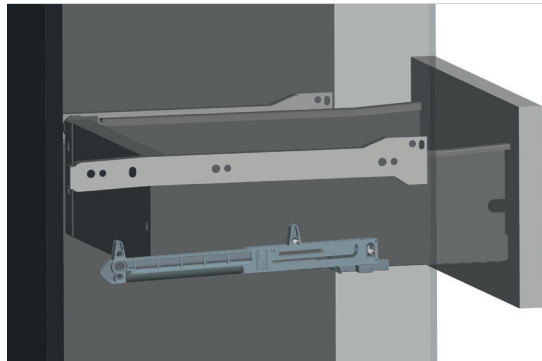
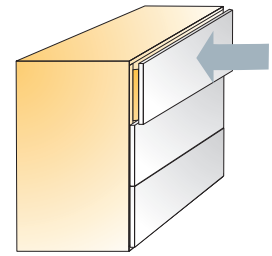

Titusoft MD

Titusoft mechanism for factory mounting

Titusoft mechanism for retrofit mounting

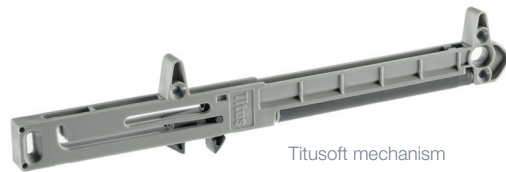

Titusoft mechanism

Activator

Mounting jig

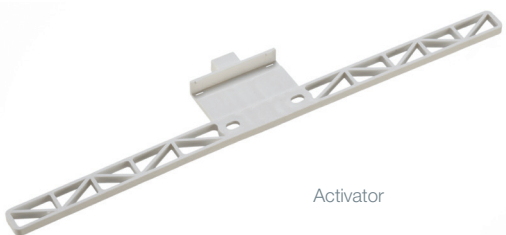

Activator



Mounting jig

Item number	Grey	White	Light blue
973.0X95 →	380		
973.0X39 →	380		
973.4125 →		350	
973.4126 →			309
Bag of 1 973.0X39.380.K2			90 bags
<ul style="list-style-type: none"> · 1 Titusoft mechanism · 1 activator · 1 mounting jig · 4 screws · 1 mounting instruction sheet 			
Bag of 2 973.0X39.380.K1			60 bags
<ul style="list-style-type: none"> · 2 Titusoft mechanisms · 2 activators · 1 mounting jig · 8 screws · 1 mounting instruction sheet 			

250 Pcs

Made of plastic

Technical details

Retrofit mounting

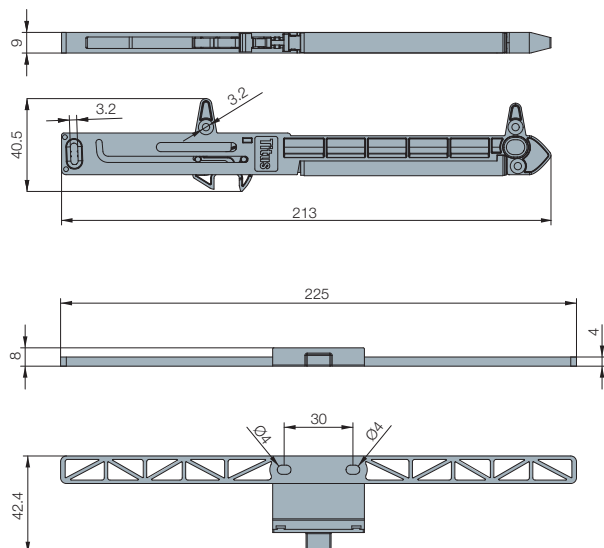

Factory mounting (system holes)

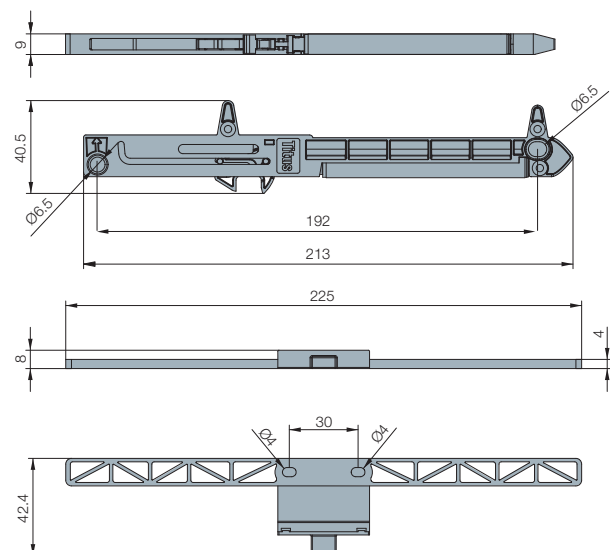

- One-for-all soft closing for single skin metal boxes
- Allows for easy factory mounting or retrofit application
- Intuitive positioning
- Preserve the life-time of the drawer

Capacity chart

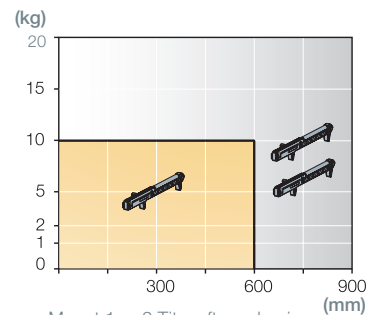

Mount 1 or 2 Titusoft mechanisms depending on drawer weight and width

Mounting details

Retrofit mounting

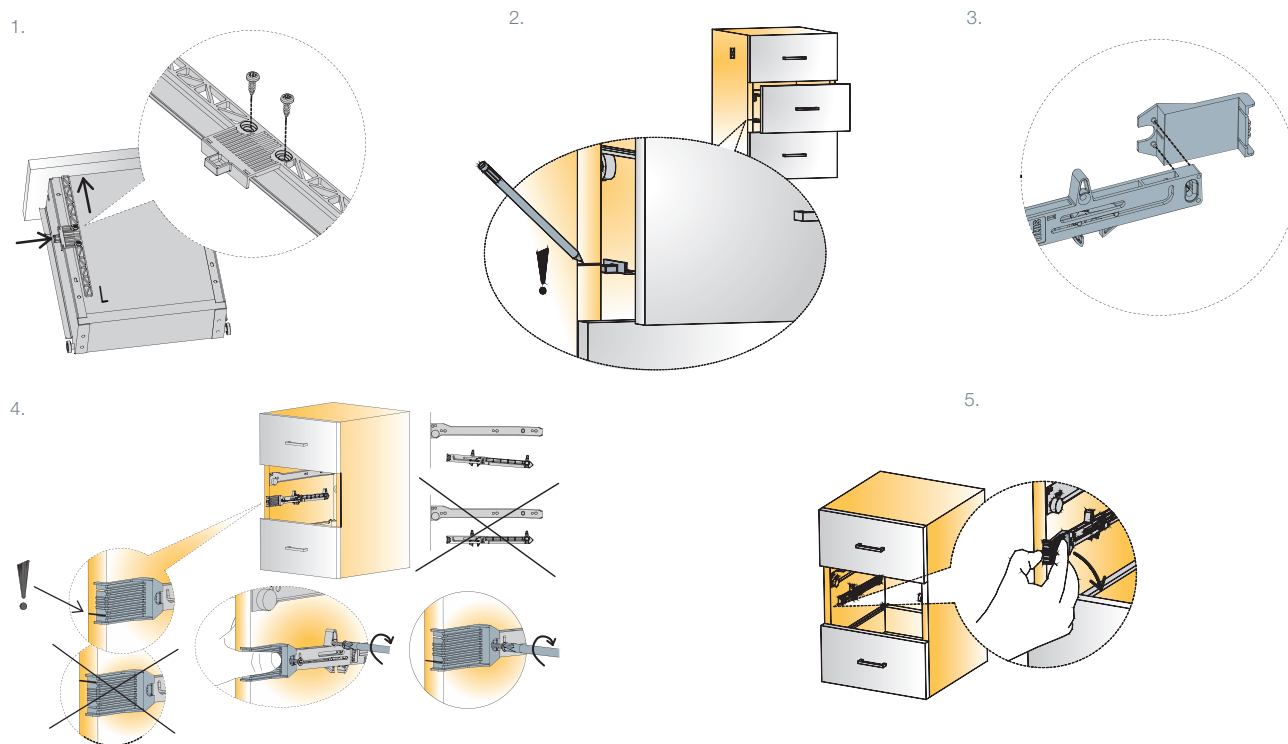

Factory mounting

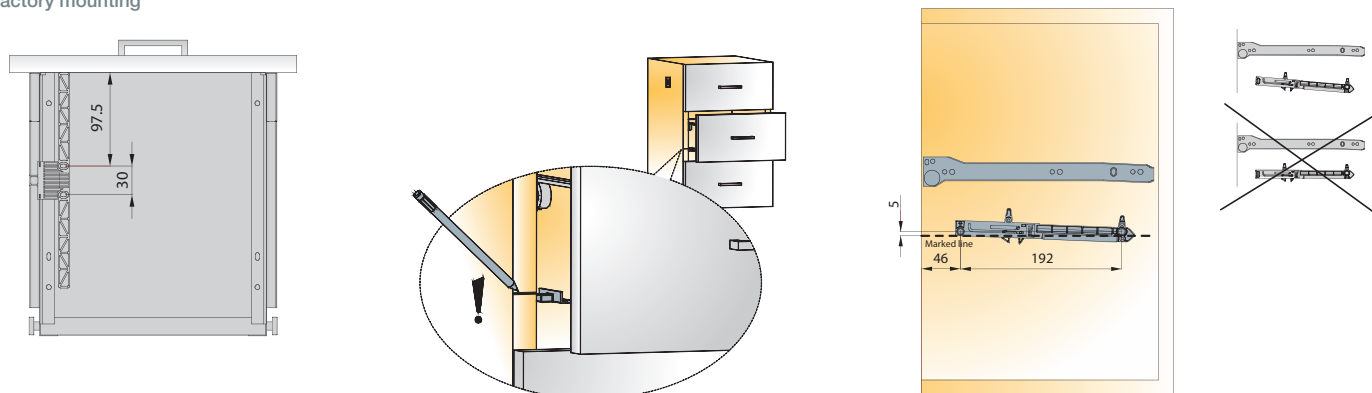

Further explanations → go to



<http://www.youtube.com/watch?v=Qplq8uKgbng>

A trial mounting is always recommended. For further information please contact your Titus Tekform representative.

Push Latch

For wooden drawers

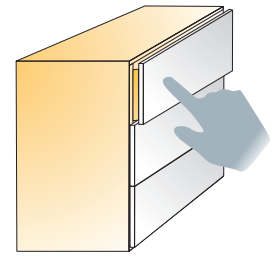

Push Latch

Cross mounting plate

Item number

915.0X59.381 →

Bronze

K1*

Linear mounting plate

915.0X59.381 →

K2

**Available upon special request*

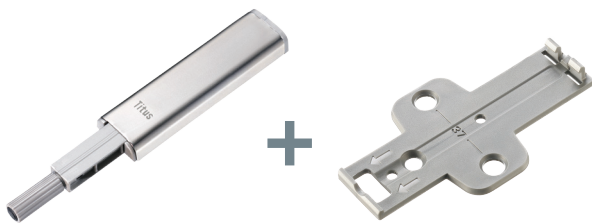

Push latch

Cross mounting plate

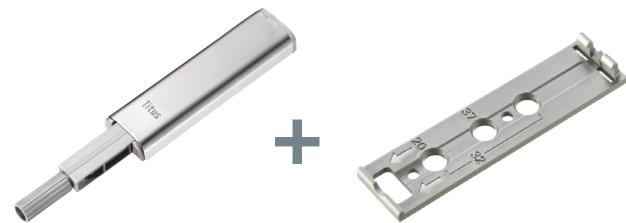

Push latch

Linear mounting plate

 200 Sets

Made of steel and plastic

Fixing screws for front brackets and drawer runner

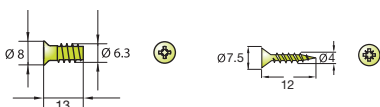

Euro screws
611.8E22.360.013

Chipboard screws
611.8K16.240.016

 10000 Pcs

- Works with Tekform Single Wall Drawers
- Effortless opening with just a light touch
- Depth adjustment ensures reliable closing and consistent performance in cases of inaccurate drilling
- 'Safety click' feature for easy detachment of the mechanism from the mounting plate

Drilling patterns

Dimensions

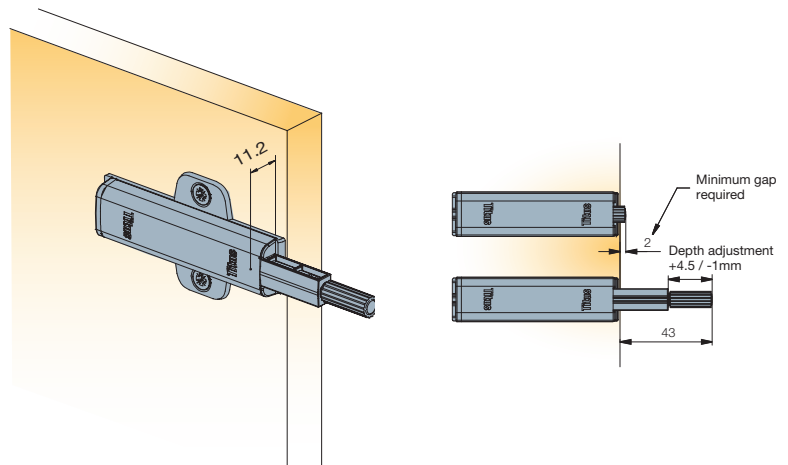
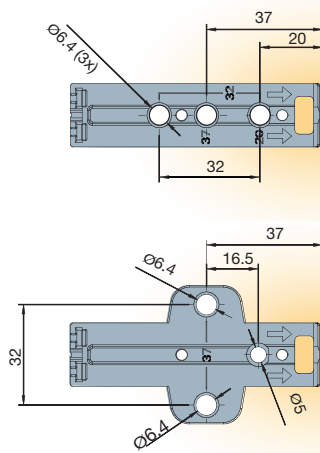

Positioning

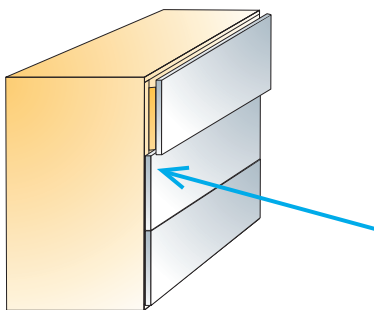

On the cabinet side; gap between drawer and cabinet side = min. 12mm

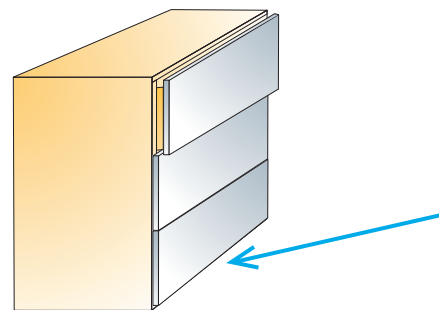

On the drawer bottom; in the middle of the drawer

Push latch works on drawer; the gap between the drawer and the cabinet side = min. 13.4mm

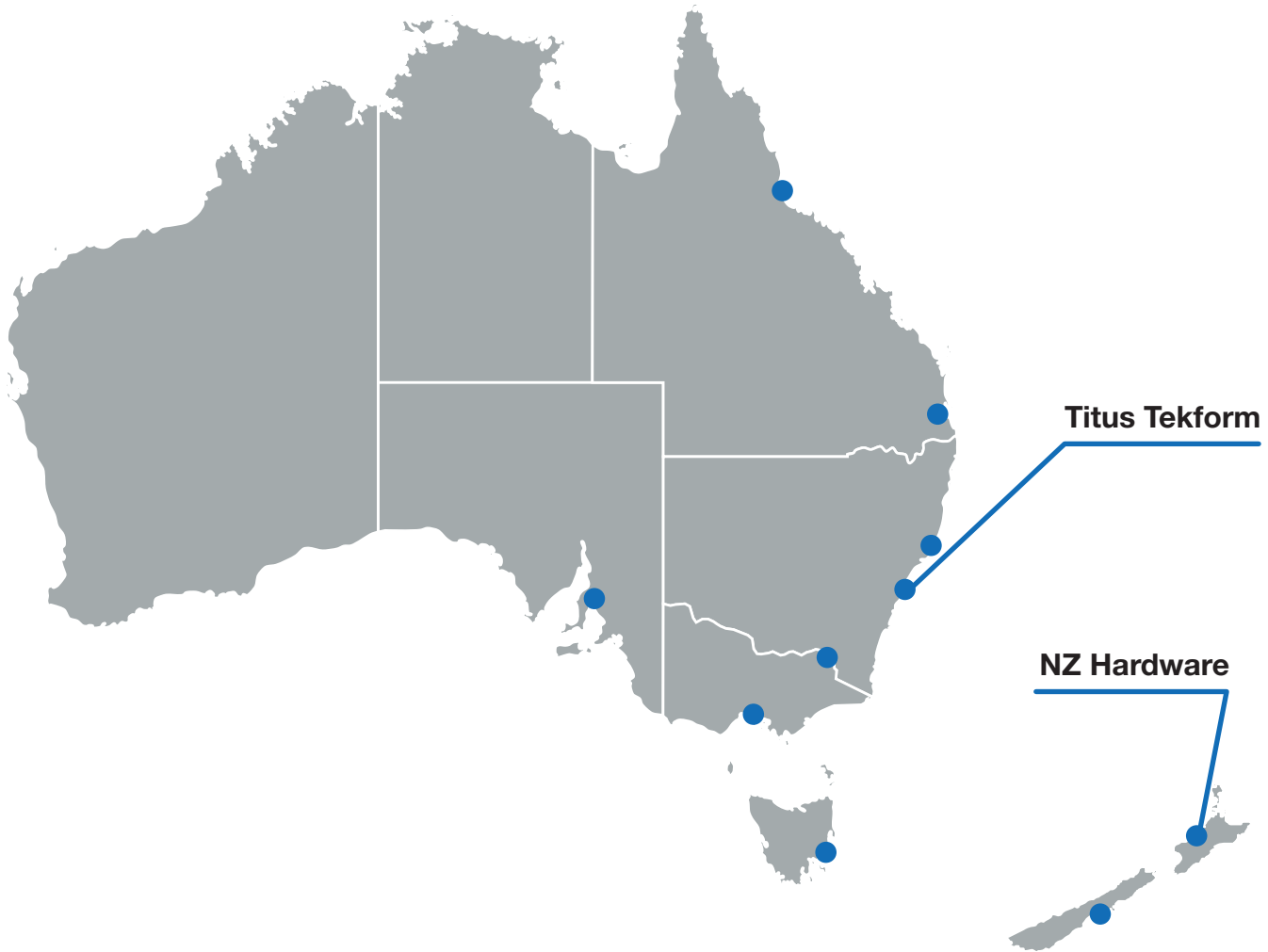

New South Wales

Titus Tekform Pty Ltd
 Unit 1&2, 41-43 Whyalla Place
 Prestons, NSW, 2170 Australia
 T: +61 2 9826 0007
 Fax: +61 2 9826 0074
 ABN: 67 168 439 647

Titus Tekform Pty Ltd
 Unit 3, 100 Munibung Road
 Cardiff, NSW, 2285 Australia
 T: +61 2 4954 4011
 Fax: +61 2 4954 4233

Tasmania

Titus Tekform Pty Ltd
 88 Hopkins Street
 Moonah, TAS, 7009 Australia
 T: +61 3 6273 1199
 Fax: +61 3 6273 0050
 PO Box 658
 Moonah, TAS, 7009

Queensland

Titus Tekform Pty Ltd
 1/32 Northlink Place
 Virginia, QLD, 4014 Australia
 T: +61 7 3266 3999
 Fax: +61 7 3266 5234
 PO Box 266
 Northgate, QLD, 4013

Titus Tekform Pty Ltd
 20 Civil Road
 Garbutt, QLD, 4814 Australia
 T: +61 7 4779 1366
 Fax: +61 7 4779 1316

South Australia

Titus Tekform Pty Ltd
 PO Box 357
 Bayswater, VIC, 3153 Australia
 T: +61 8 8447 3700
 Fax: +61 8 8447 3183

Victoria

Titus Tekform Pty Ltd
 8/59 Jersey Road
 Bayswater, VIC, 3153 Australia
 T: +61 3 9737 5566
 Fax: +61 3 9729 8780
 PO Box 357
 Bayswater, VIC, 3153

Titus Tekform Pty Ltd
 2/20 Mint Street
 Wodonga, VIC, 3690 Australia
 T: +61 2 6056 3188
 Fax: +61 2 6056 3190

Christchurch

Stefano Oriati
 162 Wordsworth Street
 Sydenham, Christchurch, 8023 NZ
 T: 0064-3-981-8518
 Fax: 0064-3-942-7296

Auckland

Stefano Oriati
 34 Waipareira Ave
 Henderson, Auckland, 0610 NZ
 T: 0064-9-8370886
 Fax: 0064-9-8378003

Get in touch with your local Technical Sales Representative

web: www.titustekform.com.au or www.stefanohardware.com

email us at info@titustekform.com.au or info@nzhe.co.nz

