

Technical Data Sheet

90cm Slide-out Rangehood

604.8A44.024.002 SL93R

Titus
Tekform



INALT^o

DIMENSIONS & TECHNICAL DRAWINGS

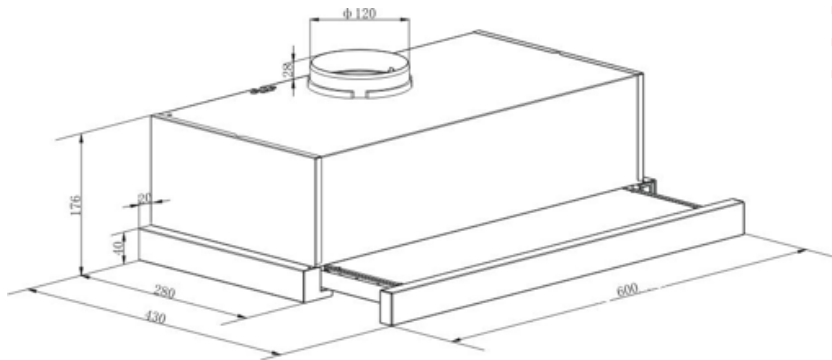

FEATURES

- 3 speed settings
- 2 ECO halogen lights
- 2 aluminium grease filters
- Slide controls

Details & Ordering Information

PERFORMANCE FEATURES

440 m³/hr extraction
Motor type: centrifugal
Decibel rating (dBA) max: 52-61 dBA

CLEANING

Dishwasher safe aluminium grease filters

ACCESSORIES

Expandable 150mm ducting adapter
2 Fascia rails included:
> 40mm for ducted installation
> 80mm for recirculating installation

OPTIONAL ACCESSORIES

Carbon filter

PRODUCT DIMENSIONS

Packaged (W D H mm): 965 x 225 x 355mm
Physical (W D H mm): 900 x 280-430 x 176mm
Weight: 12kg

REQUIREMENTS

Rated voltage: 220-240V, 50/60 Hz
Supplied with 10 amp plug

WARRANTY

24 months