

Technical Data Sheet

60cm Curved Glass Canopy Rangehood

604.8A44.020.002 RH62GB0

Titus
Tekform



INALTO

DIMENSIONS & TECHNICAL DRAWINGS

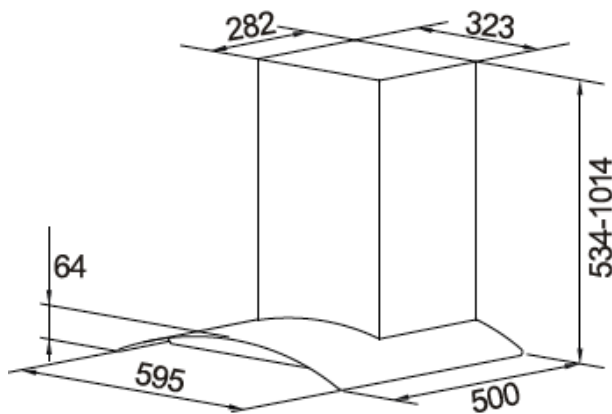

FEATURES

- 3 speed settings
- 2 LED lights
- 1 stainless steel baffle grease filter
- Black glass fascia with touch activated controls
- Stainless steel body

Details & Ordering Information

PERFORMANCE FEATURES

750 m3/hr extraction
Motor type: centrifugal
Decibel rating (dBA) max: 65 dBA

CLEANING

Dishwasher safe stainless steel baffle grease filter

ACCESSORIES

Expandable 150mm ducting adapter
Fasteners & wall plugs
2 piece stainless steel flue (upper & lower pieces)
Wall brackets

OPTIONAL ACCESSORIES

Carbon filter
Flue extension piece

PRODUCT DIMENSIONS

Packaged (W D H mm): 655 x 395 x 560mm
Physical (W D H mm): 600 x 500 x 534-1014mm
Weight: 13kg

REQUIREMENTS

Rated voltage: 220-240V, 50/60 Hz
Supplied with 10 amp plug

WARRANTY

24 months