

# Technical Data Sheet

## 60cm Canopy Rangehood

604.8A44.020.001 RH60

Titus  
Tekform



INALT<sup>o</sup>

### DIMENSIONS & TECHNICAL DRAWINGS

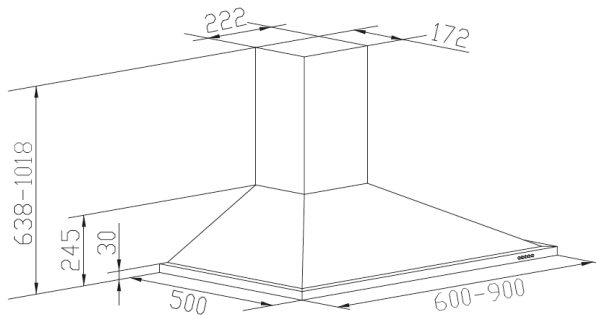

### FEATURES

- 3 speed settings
- 2 LED lights
- 2 baffle grease filters
- Push button controls
- Stainless steel body

## Details & Ordering Information

### PERFORMANCE FEATURES

750 m<sup>3</sup>/hr extraction  
Motor type: centrifugal  
Decibel rating (dBA) max: 67 dBA

### CLEANING

Dishwasher safe stainless steel baffle grease filters

### ACCESSORIES

Expandable 150mm ducting adapter  
Fasteners & wall plugs  
2 piece stainless steel flue (upper & lower pieces)  
Wall brackets

### OPTIONAL ACCESSORIES

Carbon filter  
Flue extension piece

### PRODUCT DIMENSIONS

Packaged (W D H mm): 655 x 320 x 560mm  
Physical (W D H mm): 600 x 500 x 638-1018mm  
Weight: 10kg

### REQUIREMENTS

Rated voltage: 220-240V, 50/60 Hz  
Supplied with 10 amp plug

### WARRANTY

24 months