

Technical Data Sheet

52cm Undermount Rangehood

604.8A44.026.001 RUM52

Titus
Tekform



INALT^o

DIMENSIONS & TECHNICAL DRAWINGS

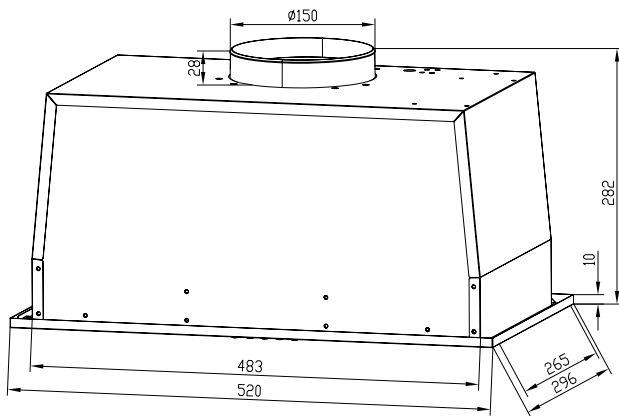

FEATURES

- 3 speed settings
- 2 LED lights
- 1 aluminium grease filter
- Push button controls

Details & Ordering Information

PERFORMANCE FEATURES

750 m³/hr extraction
Motor type: centrifugal
Decibel rating (dBA) max: 64-69 dBA

CLEANING

Dishwasher aluminium grease filter

ACCESSORIES

Expandable 150mm ducting adapter
Air outlet adapter
Pack of screws

OPTIONAL ACCESSORIES

Carbon filter

PRODUCT DIMENSIONS

Packaged (W D H mm): 560 x 335 x 335mm
Physical (W D H mm): 520 x 296 x 282mm
Weight: 7.84kg

REQUIREMENTS

Rated voltage: 220-240V, 50/60 Hz
Supplied with 10 amp plug

WARRANTY

24 months